



Patent Pending

intelligent motion systems, inc.
Excellence in Motion™



Sizes
17, 23 & 34

OPERATING INSTRUCTIONS

The information in this book has been carefully checked and is believed to be accurate; however, no responsibility is assumed for inaccuracies.

*Intelligent Motion Systems, Inc., reserves the right to make changes without further notice to any products herein to improve reliability, function or design. Intelligent Motion Systems, Inc., does not assume any liability arising out of the application or use of any product or circuit described herein; neither does it convey any license under its patent rights of others. Intelligent Motion Systems and **IMS**[™] are trademarks of Intelligent Motion Systems, Inc.*

Intelligent Motion Systems, Inc.'s general policy does not recommend the use of its products in life support or aircraft applications wherein a failure or malfunction of the product may directly threaten life or injury. Per Intelligent Motion Systems, Inc.'s terms and conditions of sales, the user of Intelligent Motion Systems, Inc., products in life support or aircraft applications assumes all risks of such use and indemnifies Intelligent Motion Systems, Inc., against all damages.

*MDrive Motion Control
Revision 05.18.2004*

© 2003 Intelligent Motion Systems, Inc.
All Rights Reserved

Getting Started - MDrive Motion Control

Before you Begin

This Quick Start will allow you to rapidly set-up and connect your system and “Turn” your MDrive Motion Control utilizing the Immediate Mode of the IMS Terminal User Interface Software. However, it is recommended that you read this entire MDrive Motion Control Manual prior to placing the unit into full operation.

Tools and Equipment Required

MDrive Motion Control Unit

IMS MD-CC200-000 Communication Cable or equivalent

IMS Product CD

An Unregulated Power Supply (See specifications for your exact MDrive Motion Control and required voltage.)

Basic Tools: Wire Cutters / Strippers / Screwdriver

Wire for Power Supply (See specifications for your exact MDrive Motion Control.)

An IBM compatible PC running Windows 9x (95/98) or Windows NT (Windows NT4.0 SP6, Windows 2000 SP1, Windows XP)

10 MB hard drive space.

A free serial communications port.

Connecting the Power Supply

Using the recommended wire (see the specifications for your MDrive Motion Control), connect the DC output of the power supply to the red wire on MDrives with flying leads or Pin #7 on units with pluggable connectors.

Connect the power supply ground to the MDrive’s black flying lead or Pin #6 on pluggable units.

Connecting Communications

Connect the Host PC to the MDrive Motion Control using the IMS MD-CC200-000 Communication Cable or equivalent.

Install IMS Terminal

Insert the IMS CD into the CD Drive of your PC.

The CD will autostart to the IMS CD Main Page. If the CD does not autostart, click “Start > Run” and type “x:\IMS.exe” in the “Open” box and click OK.

NOTE: “x” is your CD ROM drive letter.

Place your mouse pointer over the MDrive Icon. The text message “MDrive Integrated Motor & Electronics” will be displayed. This verifies you have selected the correct software.

Click the MDrive Motor Icon. This opens the MDrive Index Page.

Place the mouse pointer over the menu and select IMS Terminal (Win9x) or IMS Terminal (WinNT). The displayed text will again verify your selection. Click your selection and the “Setup” dialog box will be displayed.

Click SETUP in the Setup dialog box and follow the on-screen instructions.

Once IMS Terminal is installed the Communications Settings can be checked and/or set.

Establishing Communications

Open the IMS Terminal by clicking Start>Programs>IMS Terminal>IMS Term.

On the Menu Bar click <Edit> <Preferences> to display the "Preferences" Dialog Box.

Click the “Comm Settings” tab at the top of the dialog box. The Comm Settings page will be displayed.

Under “Device” near the bottom of the box verify “MDrive” is selected. All other settings should be left as is.

Click OK.

Apply Power to the MDrive Motion Control

Verify all connections are made and apply power to the MDrive Motion Control. Upon Power-Up the following sign-on message should appear in the Terminal window:

“Copyright 2001-2003 by Intelligent Motion Systems, Inc.”

If you can see this sign-on message then you are up and running! If the sign-on message does not appear, try using a software reset. Hold down the “Ctrl” key and press “C” (^C). If the sign-on message still does not appear then there may be a problem with either the connections, hardware or software configuration of the MDrive Motion Control or Host PC.

There are indicators at the bottom of the Terminal Window that show whether you are Connected or Disconnected, the current Baud Rate and the type of device (MDrive) for which the IMS Terminal is configured. These three items may be changed directly from this screen by double clicking on them.

Double Click on “Connected” and the system will disconnect.

Double Click on “Disconnect” and the system will connect.

Testing the MDrive Motion Control Setup

NOTE: The character ^ is used to indicate a space. Do not type this character but be sure to type the space.

Click anywhere within the Terminal Window (Right Window) to activate it.

The Print instruction <PR> is used to report the values of variables and flags.

Type the following: **PR^VM** and then press ENTER.

The MDrive Motion Control should return a value of 768000

NOTE: The MDrive Motion Control is not case sensitive. You may type in lower or upper case.

Type **VM^360000** and press ENTER.

Type **PR^VM** and press ENTER.

The MDrive Motion Control should return a value of 360000

Type **FD** and press ENTER. (FD = Factory Defaults.)

The "Copyright 2001-2003 by Intelligent Motion Systems, Inc." Message should appear.

CONGRATULATIONS! You are communicating.

Make the MDrive Motion Control Move

NOTE: You may want to put a small piece of tape on the motor shaft so you can see it turn.

Type **MR^51200** and press ENTER. (MR=Move Relative.) With the Default settings, the MDrive Motion Control should move one revolution in approximately 0.066 seconds or at a velocity of 15 revolutions per sec.

Type **SL^102400** and press ENTER. (SL = Slew.) With the Default Settings, the MDrive Motion Control should run constantly at a speed of approximately 2 revolutions per second or 120 revolutions per minute.

Type **SL^0** and press ENTER. The MDrive Motion Control should decelerate to a full stop.

Motion Sample

This is a simple motion program that sets the position counter to zero (0), moves the MDrive Motion Control 102400 microsteps in the plus direction and then prints the position in the Terminal Window.

Type the following: (It is not necessary to type the comments.)

Type **P=0** 'Sets position counter to 0



Press ENTER

Type **MR^102400** 'Set motion mode to relative, move relative 102400

Press ENTER

Type **PR^P** 'Print position to terminal

Press ENTER

NOTE: The program or motion can be stopped by pressing the Escape Button  or by pressing <Ctrl C>  + .

The Motion Sample above may also be run from a program. If you wish to run from a program go to **Section 2.2** in this Manual and then go to the heading "**Creating, Downloading and Uploading Programs**". Take yourself through Creating a New Program, Formatting the Program Text and Downloading a Program to the MDrive Motion Control. At the end of the Download instructions you will be able to run the Program. Note that the Program version of the Motion Sample has examples of setting many of the common variables you will be using on a regular basis.

These are basic commands that verify that your MDrive Motion Control is communicating with your PC. More complex commands and movement may require that your I/O and/or Analog Input be interfaced and configured. Please consult the appropriate sections in this manual for details.

Table of Contents

Part 1: General Information And Hardware Information

Section 1.1: Introduction to the MDrive17 Motion Control	5
Introduction to the MDrive17 Motion Control	5
Feature Summary	5
Section 1.2: MDrive17 Motion Control Specifications	6
Section Overview	6
Rotary Motor Specifications	6
Mechanical Specifications - Dimensions in Inches (mm)	6
MDrive17 Mounting Screws	6
MDrive Motion Control 1713 Motor Specs and Speed/Torque Curves	7
MDrive Motion Control 1715 Motor Specs and Speed/Torque Curves	7
MDrive Motion Control 1719 Motor Specs and Speed/Torque Curves	7
General Specifications	8
Power Supply Requirements	9
Recommended IMS Power Supplies	9
Thermal Specifications	9
Section 1.3: Introduction to the MDrive23 Motion Control	10
Introduction to the MDrive23 Motion Control	10
Feature Summary	10
Section 1.4: Drive23 Motion Control Specifications	11
Section Overview	11
Rotary Motor Specifications	11
Mechanical Specifications - Dimensions in Inches (mm)	11
MDrive Motion Control 2218 Motor Specs and Speed/Torque Curves	11
MDrive Motion Control 2222 Motor Specs and Speed/Torque Curves	12
MDrive Motion Control 2231 Motor Specs and Speed/Torque Curves	12
Linear Motor Specifications	12
Mechanical Specifications - Dimensions in Inches (mm)	12
Linear Actuator MDrive Motion Control 2218 Specs and Speed-Force Curves	13
Speed-Force Curve: 24 VDC	13
Speed-Force Curve: 45 VDC	13
MDrive23 Motion Control ACME Screw	14
General Specifications	14
Power Supply Requirements	15
Recommended IMS Power Supplies	15
Thermal Specifications	15
Section 1.5: Introduction to the MDrive34 Motion Control	16
Introduction to the MDrive34 Motion Control	16
Feature Summary	16
Section 1.6: MDrive34 Motion Control Specifications	17
Section Overview	17
Rotary Motor Specifications	17
Mechanical Specifications - Dimensions in Inches (mm)	17
MDrive Motion Control 3424 Motor Specs and Speed/Torque Curves	18
MDrive Motion Control 3431 Motor Specs and Speed/Torque Curves	18
MDrive Motion Control 3447 Motor Specs and Speed/Torque Curves	18
General Specifications	19
Power Supply Requirements	20
Recommended IMS Power Supplies	20
Thermal Specifications	20

Part 2: Connecting, Configuring, And Programming The MDrive Motion Control

Section 2.1: Interfacing the MDrive Motion Control	22
Section Overview	22
Layout and Interface Guidelines	22
Recommended Wiring	22
Pin Configuration and Descriptions	22
Interfacing Power	23
Securing MDrive Power and Logic Leads	23
Interfacing RS-485 Communications	24
Single MDrive	24
RS-485 2 Wire Communication (Half Duplex)	24
Multiple MDrive Motion Control System (Party Mode)	25
Data Cable Termination Resistors	25
MDI Communication Format	26
MDI Response to Echo Mode	26
Using Check Sum	27
MDrive Motion Control Party Mode Sample Codes	28
MDrive Motion Control Immediate Party Mode Sample Codes	29

Interfacing the Digital I/O	30
Uses of the Digital I/O	30
Interfacing Inputs	30
Interfacing Outputs	32
Interfacing the Analog Input	33
Sample Usage	33
Section 2.2: MDrive Motion Control Software Introduction	34
Section Overview	34
Installing and Using IMS Terminal	34
System Requirements	34
Installation	34
Using the IMS Terminal Software	37
The IMS Terminal Tool Bar	37
Creating, Downloading and Uploading Programs	38
Formatting the Program Text	39
Setting the Programmable Function Keys	42
Program Troubleshooting	43
Upgrading the MDrive Motion Control Firmware	46
MDrive Motion Control Programming	49
Operational Modes	49
Basic Components of MDrive Motion Control Software	49
Instructions	49
Variables	49
Flags	50
Keywords	50
Most Commonly Used Variables and Commands	50
Variables	50
Math Functions	51
Motion Commands	51
Calculating Axis Speed (Velocity)	53
Programming with the Optional Encoder	55
I/O Commands	58
System Instructions	58
Program Instructions	58
Section 2.3: MDrive Motion Control Command Set Summary	61
Setup Instructions, Variables and Flags	61
Miscellaneous Instructions, Variables and Flags	61
Motion Instructions, Variables and Flags	61
I/O Instructions, Variables and Flags	62
Program Instructions, Variables and Flags	62
Position Related Instructions, Variables and Flags	63
Encoder Related Instructions, Variables and Flags	63
Mathematical Functions	63
Section 2.4: MDrive Motion Control Command Set	64
Appendix A: ASCII TABLE	93
Appendix B: Error Codes	94
Appendix C: Program Samples	95
Appendix D: Recommended Cable Configurations	99

List of Figures

Figure 1.1	Rotary MDrive17 Motion Control Mechanical Specifications	6
Figure 1.2	MDrive17 Mounting Screw Depth	6
Figure 1.3	Rotary MDrive17 Motion Control 1713 Speed/Torque Data	7
Figure 1.4	Rotary MDrive17 Motion Control 1715 Speed/Torque Data	7
Figure 1.5	Rotary MDrive17 Motion Control 1719 Speed/Torque Data	7
Figure 1.6	Rotary MDrive23 Motion Control Mechanical Specifications	11
Figure 1.7	Rotary MDrive23 Motion Control 2218 Speed/Torque Data	11
Figure 1.8	Rotary MDrive23 Motion Control 2222 Speed/Torque Data	12
Figure 1.9	Rotary MDrive23 Motion Control 2231 Speed/Torque Data	12
Figure 1.10	Linear Actuator MDrive23 Motion Control Mechanical Specifications	12
Figure 1.11	Speed-Force Curve - 24VDC (100% Current)	13
Figure 1.12	Speed-Force Curve - 45VDC (100% Current)	13
Figure 1.13	Rotary MDrive34 Motion Control Mechanical Specifications	17
Figure 1.14	Rotary MDrive34 Motion Control 3424 Speed/Torque Data	18
Figure 1.15	Rotary MDrive34 Motion Control 3431 Speed/Torque Data	18
Figure 1.16	Rotary MDrive34 Motion Control 3447 Speed/Torque Data	18
Figure 2.1	Power Supply Interface	23
Figure 2.2	Typical MDrive with Pluggable Leads Secured	23
Figure 2.3	Typical MDrive with Flying Leads Secured	23
Figure 2.4	RS-485 Interface, Single MDrive Motion Control	24

Figure 2.8	Input Interfaced to a PLC	30
Figure 2.9	TTL Interface to an Input Group	31
Figure 2.10	Output Interfaced to an LED	32
Figure 2.11	Output Interfaced to a Relay	32
Figure 2.12	Outputs Interfaced to LED's as a Group	32
Figure 2.13	Analog Input Interface	33
Figure 2.14	IMS CD Main Index Page	34
Figure 2.15	IMS CD Software Selection Page	35
Figure 2.16	IMS CD Software Setup Command	35
Figure 2.17	Main IMS Terminal Page	35
Figure 2.18	Preferences Dialog Box	36
Figure 2.19	Preferences Selection Dialog Box in the Terminal Window	36
Figure 2.20	The COMM Settings Dialog Box	36
Figure 2.21	Copyright Statement in Terminal Window	37
Figure 2.22	The IMS Terminal Tool Bar	37
Figure 2.23	Drop-Down Menu for New Edit Window	38
Figure 2.24	Naming the New Program/Program Editor Window	38
Figure 2.25	New Program Editor Window Named "motion sample.mxt"	38
Figure 2.26	Program Editor Preferences	39
Figure 2.27	Example of Indented Text	39
Figure 2.28	Formatted and Color Coded Program Text	40
Figure 2.29	Dialog Box for Changing Text Colors in the Program Editor Window	40
Figure 2.30	Program Download Drop-Down Menu	41
Figure 2.31	Download Dialog Box	41
Figure 2.32	Terminal Window Displaying Downloaded Program	41
Figure 2.33	Function Key (s) Configuration Page	42
Figure 2.34	Entering Data for the Function Key (s)	43
Figure 2.35	Activating a Function Key	43
Figure 2.36	Setting the Scroll Back Buffer	44
Figure 2.37	The Capture Dialog Box	45
Figure 2.38	Capture OFF Indicator	45
Figure 2.39	Capture ON Indicator	45
Figure 2.40	Stop Capture Command in Transfer Drop-Down Menu	45
Figure 2.41	Trapezoidal Move Profile	53
Figure 2.42	Rotary Drive Example	54
Figure 2.43	Quadrature Encoder Pulses	55
Figure 2.44:	EE=1 Flowchart	57

List of Tables

Table 1.1	Rotary MDIF1713 Motor Specifications	7
Table 1.2	Rotary MDIF1715 Motor Specifications	7
Table 1.3	Rotary MDIF1719 Motor Specifications	7
Table 1.4	Rotary MDI2218 Motor Specifications	11
Table 1.5	Rotary MDI2222 Motor Specifications	12
Table 1.6	Rotary MDI2231 Motor Specifications	12
Table 1.7	Linear Actuator MDrive23 Motion Control Motor Specifications	13
Table 1.8	ACME Screws for Linear Actuator MDrive23 Motion Control	14
Table 1.9	Rotary MDIF3424 Motor Specifications	18
Table 1.10	Rotary MDIF3431 Motor Specifications	18
Table 1.11	Rotary MDIF3447 Motor Specifications	18
Table 2.1	P1 Pin Configuration and Description	22
Table 2.2	P2 Pin Configuration and Description	23
Table 2.3	MDI Response to Echo Mode when Party and Check Sum are Zero (0)	26
Table 2.4	MDI Response to Echo Mode when Party is One (1) and Check Sum is Zero (0)	26
Table 2.5	MDI Response to Echo Mode when Party is Zero (0) and Check Sum is One (1)	27
Table 2.6	MDI Response to Echo Mode when Party and Check Sum are One (1)	27
Table 2.7	Input Functions	30
Table 2.8	I/O Group Truth Table	31
Table 2.9	Output Functions	32
Table 2.10	Microstep Resolution Settings	80

Part 1: General Information and Hardware Specifications

Section 1.1

Introduction to the MDrive17 Motion Control

Introduction to the MDrive17 Motion Control

The MDrive17 Motion Control offers the system designer a low-cost, intelligent motion controller integrated with a NEMA 17 high torque stepping motor and a +12 to +48 VDC microstepping drive.

The MDrive17 Motion Control adds a versatile array of functions by combining a complete programmable motion controller with our already compact and cost effective standard MDrive17, adding little cost and no increase in size. Standard offerings include four +5V logic to +24V logic programmable I/O points, one 10-bit 0 to 5 volt analog input, 0 to 5 MHz step clock rate, microstep resolution up to 51,200 steps per revolution and a full featured easy-to-program instruction set.

The MDrive17 Motion Control communicates using the RS-485 communications protocol, this allows for point-to-point or multi-drop communications using one communications port. Addressing and hardware support up to 62 MDrive nodes in a system. The communications BAUD rate is software selectable and ranges from 4.8 kbps to 115 kbps.

The MDrive17 is also available with an optional closed loop control. The closed loop configuration adds a 512 line (2048 count) internal magnetic rotary encoder with index mark without increasing the length of the unit. Closed loop configuration adds position maintenance, stall detection and find index mark.

Available motor configurations include a single shaft and an external linear actuator only (consult factory for availability). Rotary versions are available in three motor lengths: 13, 15 & 19. Interface connections are accomplished with 12" flying leads.

Feature Summary

- Integrated Microstepping Drive/Motion Controller with Optional Encoder/NEMA 17 High Torque Stepping Motor
- +12 to +48VDC Input Voltage
- Low Cost
- Extremely Compact
- Available Configurations: Single Shaft, External Linear Actuator (Consult Factory for Availability), Integral Encoder
- Three Motor Stack Lengths Available
- Single Power Supply
- Microstep Resolution up to 51,200 Steps Per Revolution
- Open Loop or Optional Closed Loop Control
- Programmable Motor Run and Hold Current Settings
- Four 0V to 24V Inputs that work with +5V Logic (i.e. TTL, CMOS, etc.) or +24V Logic (i.e. PLC's)
- One Analog 10 Bit, 0 to 5 Volt Analog Input
- 0 to 5 MHz Step Clock Rate, Selectable in 0.59 Hz Increments
- RS-485 Communications Protocol
- Communications BAUD Rate Selectable from 4.8 kbps to 115 kbps
- 62 Software Addresses for Multidrop Communications
- Simple 1 and 2 Character Programming Instructions
- 12" Flying Lead Interface
- Optional Integrated RS-232 to RS-485 Converter/Communications Cable

Section 1.2

MDrive17 Motion Control Specifications

Section Overview

This section contains mechanical, motor and electrical specifications specific to each version of the MDrive17 Motion Control. Shown are:

- Rotary Motor Specifications
- General Specifications
- Power Supply Requirements
- Thermal Specifications

Rotary Motor Specifications

Mechanical Specifications - Dimensions in Inches (mm)

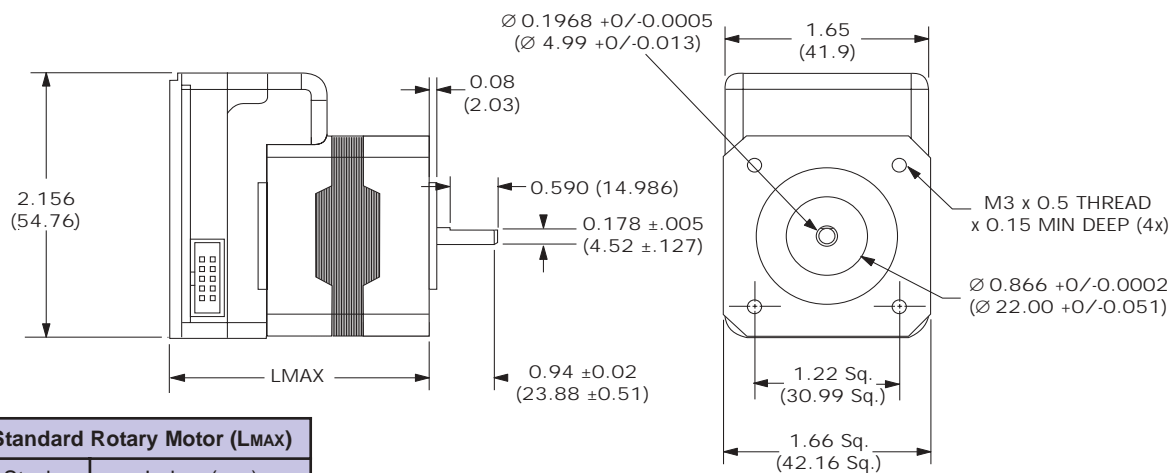

Standard Rotary Motor (LMAX)	
Stack	Inches (mm)
1713	2.187 (55.56)
1715	2.407 (61.15)
1719	2.786 (70.77)

Figure 1.1: Rotary MDrive17 Motion Control Mechanical Specifications

MDrive17 Mounting Screws

Care must be observed when installing the mounting screws on ALL MDrive17 versions including Linear Actuators. The mounting holes on the flange are not drilled through and have a maximum depth of 0.150" (3.81 mm).

The warning and note below as well as Figure 1.2 illustrate the maximum safe thread length and maximum torque for mounting all versions of the MDrive17.

WARNING! The mounting holes in the MDrive17 mounting flange are **not through holes**. The maximum length of the screw threads into the motor flange is 0.140" (3.5 mm). (See Below)

N **MAXIMUM TORQUE!** The maximum torque for the M3x0.5 screw is 7.8 lb-in (9 kg-cm) with a thread engagement of 6.5 threads (3.3 mm deep). A lesser thread engagement diminishes the maximum torque.

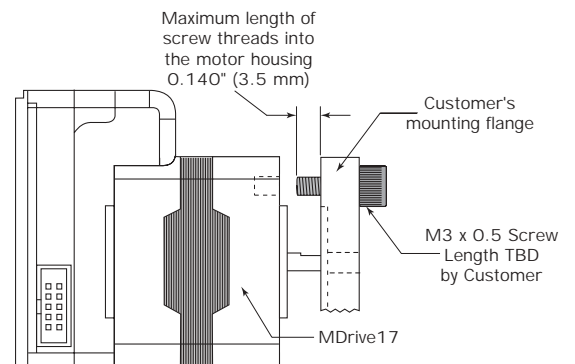

Figure 1.2: MDrive17 Mounting Screw Depth

MDrive Motion Control 1713 Motor Specs and Speed/Torque Curves

MDIF1713	
Holding Torque oz-in (N-cm)	32 (22.6)
Detent Torque oz-in (N-cm)	1.66 (1.17)
Rotor Inertia oz-in-sec ² (kg-cm ²)	0.00053 (0.038)
Weight (Motor+Driver) oz (gm)	8.26 (234.2)

Table 1.1: Rotary MDIF1713 Motor Specifications

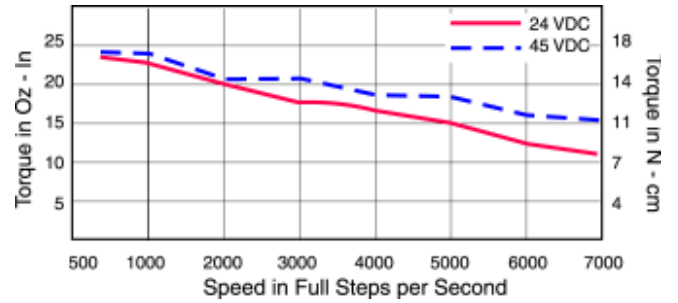

Figure 1.3: Rotary MDrive Motion Control 1713 Speed/Torque Data

MDrive Motion Control 1715 Motor Specs and Speed/Torque Curves

MDIF1715	
Holding Torque oz-in (N-cm)	60 (42.4)
Detent Torque oz-in (N-cm)	2.08 (1.47)
Rotor Inertia oz-in-sec ² (kg-cm ²)	0.00080 (0.057)
Weight (Motor+Driver) oz (gm)	10.42 (295.4)

Table 1.2: Rotary MDIF1715 Motor Specifications

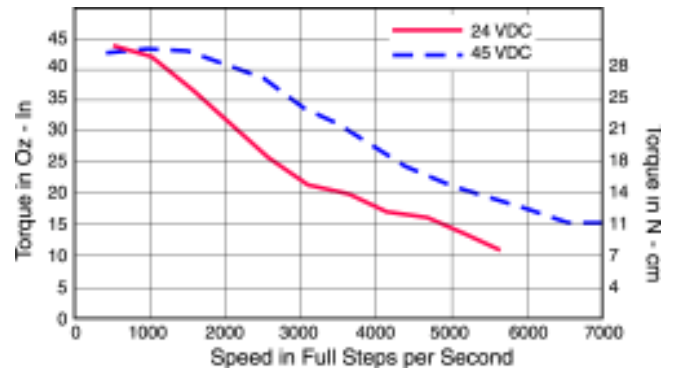

Figure 1.4: Rotary MDrive Motion Control 1715 Speed/Torque Data

MDrive Motion Control 1719 Motor Specs and Speed/Torque Curves

MDIF1719	
Holding Torque oz-in (N-cm)	74.9 (52.9)
Detent Torque oz-in (N-cm)	3.47 (2.45)
Rotor Inertia oz-in-sec ² (kg-cm ²)	0.00116 (0.082)
Weight (Motor+Driver) oz (gm)	11.80 (334.5)

Table 1.3: Rotary MDIF1719 Motor Specifications

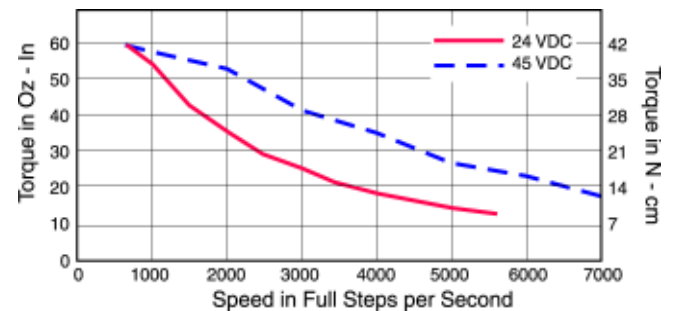
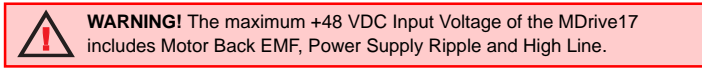

Figure 1.5: Rotary MDrive Motion Control 1719 Speed/Torque Data

General Specifications - MDrive17 Motion Control

Input Voltage (+V)

Range +12 to +48 VDC



A characteristic of all motors is back EMF. Back EMF is a source of current that can push the output of a power supply beyond the maximum operating voltage of the driver. As a result, damage to the stepper driver could occur over a period of time. Care should be taken so that the back EMF does not exceed the maximum input voltage rating of the MDrive17.

Analog Input

Resolution 10 Bit
 Voltage Range 0 to +5 Volts
 Current Range 4 - 20 mA

Programmable I/O

Number 4
 Interface Type Open Collector
 Voltage Range 0 to +24 VDC
 Logic Threshold
 Logic 0 <0.8VDC
 Logic 1 >2.2VDC
 Output Sink Current 700 mA
 Protection Over Temp., Short Circuit, Inductive Clamp

Communication

Protocol RS-485, Full/Half Duplex Selectable
 BAUD Rate 4800, 9600, 19.2k, 38.4k, 115.2k

Motion

Microstep Resolution – Open Loop Configuration

Number of Settings 14
 Steps per Revolution 400, 800, 1000, 1600, 2000, 3200, 5000, 6400,
 10000, 12800, 25000, 25600, 50000, 51200

Microstep Resolution – Closed Loop Configuration (Optional)

Steps per Revolution (Fixed) 51200

Encoder (Optional)

Type Internal, Magnetic
 Resolution 512 Lines/2048 counts per Revolution

Counters

Type Position(C1), Encoder (C2)
 Resolution 32 Bit
 Edge Rate (Max) 5 MHz

Velocity

Range ±5,000,000 Steps per Second
 Resolution 1 Step per Second

Acceleration/Deceleration

Range 1.5 x 10⁹ Steps per Second²
 Resolution 90.9 Steps per Second²

Software

Program and Data Storage	Non-Volatile
User Program Space	767 Bytes
User Registers	4, 32 Bit
User Program Labels & Variables	22
Math, Logic AND Conditional Functions	+, -, x, ÷, <, >, =, <=, >=, & (AND), (OR), ^ (XOR), ! (NOT)
Branch Functions	Branch & Call (Conditional)
Predefined I/O Functions	
Inputs	Home, Limit +, Limit -, Go, Soft Stop, Pause, Jog +, Jog -, Analog Input
Outputs	Moving, Fault
Trip Functions	Input, Position
Party Mode Node Addresses	62
Encoder Functions	Stall Detect, Position Maintenance, Find Index

Power Supply Requirements

Each MDrive17 Motion Control will require a **maximum power supply current of 2A**. Actual power supply current will depend upon the load and duty cycle.



WARNING:

- DO NOT connect or disconnect power leads when power is applied!
- Disconnect the AC power side to power down the DC power supply.
- For battery operated systems, connect a "transient suppressor" across the power switch to prevent arcs and high voltage spikes.

Recommended IMS Power Supplies

For the MDrive17 Motion Control, below are the recommended IMS power supplies.

IP404 Unregulated Linear Supply

Input Range	
120 VAC Versions	102-132 VAC
240 VAC Versions	204-264 VAC
Output	
No Load Output Voltage*	43 VDC @ 0 Amps
Continuous Output Rating*	32 VDC @ 2 Amps
Peak Output Rating*	26 VDC @ 4 Amps

ISP200-4 Unregulated Linear Supply

Input Range	
120 VAC Versions	102-132 VAC
240 VAC Versions	204-264 VAC
Output	
No Load Output Voltage*	41 VDC @ 0 Amps
Continuous Output Rating*	38 VDC @ 1.5 Amps
Peak Output Rating*	35 VDC @ 3 Amps

* All measurements were taken at 25°C, 120 VAC, 60 Hz.



WARNING! The maximum +48 VDC Input Voltage of the MDrive17 includes Motor Back EMF, Power Supply Ripple and High Line.

Thermal Specifications

Because the MDrive consists of two core components, a drive and a motor, close attention must be paid to the thermal environment where the device is used. The following maximum temperatures apply to the MDrive17:

Heatsink Temperature - Max	85°C
Motor Temperature - Max	100°C

Section 1.3

Introduction to the MDrive23 Motion Control

Introduction to the MDrive23 Motion Control

The MDrive23 Motion Control offers the system designer a low-cost, intelligent motion controller integrated with a NEMA 23 high torque stepping motor and a +12 to +48 VDC microstepping drive.

The MDrive23 Motion Control adds a versatile array of functions by combining a complete programmable motion controller with our already compact and cost effective standard MDrive23, adding little cost and no increase in size. Standard offerings include four +5V logic to +24V logic programmable I/O points, one 10-bit 0 to 5 volt analog input, 0 to 5 MHz step clock rate, microstep resolution up to 51,200 steps per revolution and a full featured easy-to-program instruction set.

The MDrive23 Motion Control communicates using the RS-485 communications protocol, this allows for point-to-point or multi-drop communications using one communications port. Addressing and hardware support up to 62 MDrive nodes in a system. The communications BAUD rate is software selectable and ranges from 4.8 kbps to 115 kbps.

The MDrive23 is also available with an optional closed loop control. The closed loop configuration adds a 512 line (2048 count) internal magnetic rotary encoder with index mark without increasing the length of the unit. Closed loop configuration adds position maintenance, stall detection and find index mark.

Available motor configurations include: single shaft, double shaft with control knob, and long life ACME screw linear actuator. Rotary versions are available in three motor lengths: 18, 22 & 31. Interface connections are accomplished using either a 7 position terminal block or optional 12" flying leads.

Feature Summary

- Integrated Microstepping Drive/Motion Controller with Optional Encoder/NEMA 23 High Torque Stepping Motor
- +12 to +48VDC Input Voltage
- Low Cost
- Extremely Compact
- Available Configurations: Single Shaft*, Linear Actuator, Integral Encoder*, Double Shaft with Knob for Manual Positioning*
- Three Motor Stack Lengths Available*
- Single Power Supply
- Microstep Resolution up to 51,200 Steps Per Revolution
- Open Loop or Optional Closed Loop Control
- Programmable Motor Run and Hold Current Settings
- Four 0V to 24V Inputs that work with +5V Logic (i.e. TTL, CMOS, etc.) or +24V Logic (i.e. PLC's)
- One Analog 10 Bit, 0 to 5 Volt Analog Input
- 0 to 5 MHz Step Clock Rate, Selectable in 0.59 Hz Increments
- RS-485 Communications Protocol
- Communications BAUD Rate Selectable from 4.8 kbps to 115 kbps
- 62 Software Addresses for Multidrop Communications
- Simple 1 and 2 Character Programming Instructions
- Pluggable Terminal Strip or 12" Flying Lead Interface
- Optional Integrated RS-232 to RS-485 Converter/Communications Cable

*Rotary Motor Only

Section 1.4

MDrive23 Motion Control Specifications

Section Overview

This section contains mechanical, motor and electrical specifications specific to each version of the MDrive23 Motion Control. Shown are:

- Rotary Motor Specifications
- Linear Motor Specifications
- General Specifications
- Power Supply Requirements
- Thermal Specifications

Rotary Motor Specifications

Mechanical Specifications - Dimensions in Inches (mm)

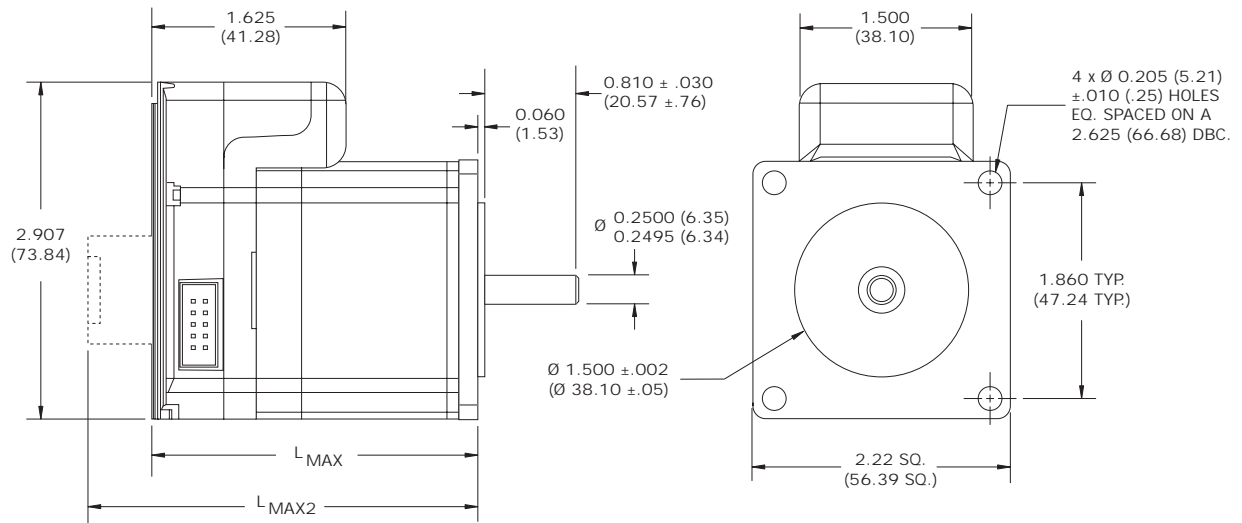

Standard Rotary Motor (L_{MAX})	
Stack	In (mm)
2218	2.632 (66.85)
2222	3.000 (76.20)
2231	3.960 (100.58)

Control Knob (L_{MAX2})	
Stack	In (mm)
2218	3.088 (78.44)
2222	3.537 (89.84)
2231	4.416 (112.17)

Figure 1.6: Rotary MDrive23 Motion Control Mechanical Specifications

MDrive Motion Control 2218 Motor Specs and Speed/Torque Curves

MDI2218	
Holding Torque oz-in (N-cm)	90 (64)
Detent Torque oz-in (N-cm)	3.5 (2.5)
Rotor Inertia oz-in-sec ² (kg-cm ²)	0.0025 (0.18)
Weight (Motor+Driver) oz (gm)	20.1 (569.8)

Table 1.4: Rotary MDI2218 Motor Specifications

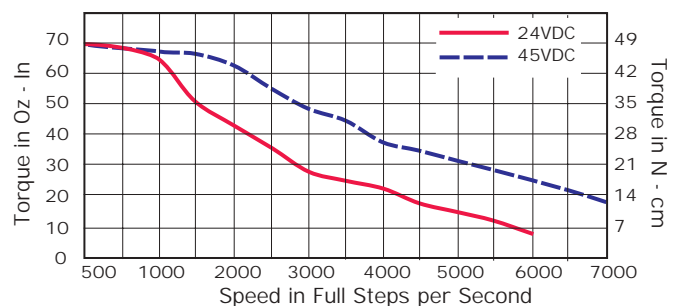

Figure 1.7: Rotary MDrive Motion Control 2218 Speed/Torque Data

MDrive Motion Control 2222 Motor Specs and Speed/Torque Curves

MDI2222	
Holding Torque oz-in (N-cm)	144 (102)
Detent Torque oz-in (N-cm)	5.6 (3.92)
Rotor Inertia oz-in-sec ² (kg-cm ²)	0.0037 (0.26)
Weight (Motor+Driver) oz (gm)	24.4 (691.7)

Table 1.5: Rotary MDI2222 Motor Specifications

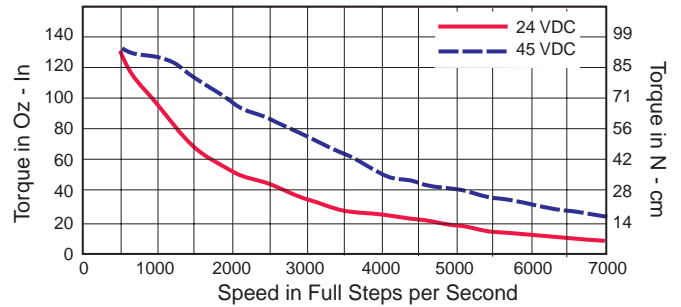

Figure 1.8: Rotary MDrive Motion Control 2222 Speed/Torque Data

MDrive Motion Control 2231 Motor Specs and Speed/Torque Curves

MDI2231	
Holding Torque oz-in (N-cm)	239 (169)
Detent Torque oz-in (N-cm)	9.7 (6.86)
Rotor Inertia oz-in-sec ² (kg-cm ²)	0.0065 (0.46)
Weight (Motor+Driver) oz (gm)	38.5 (1091.5)

Table 1.6: Rotary MDI2231 Motor Specifications

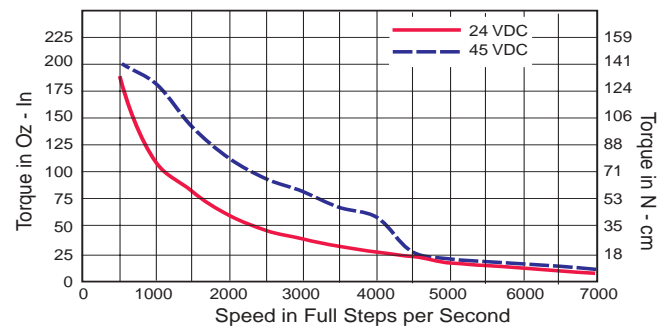

Figure 1.9: Rotary MDrive Motion Control 2231 Speed/Torque Data

Linear Motor Specifications

Mechanical Specifications - Dimensions in Inches (mm)

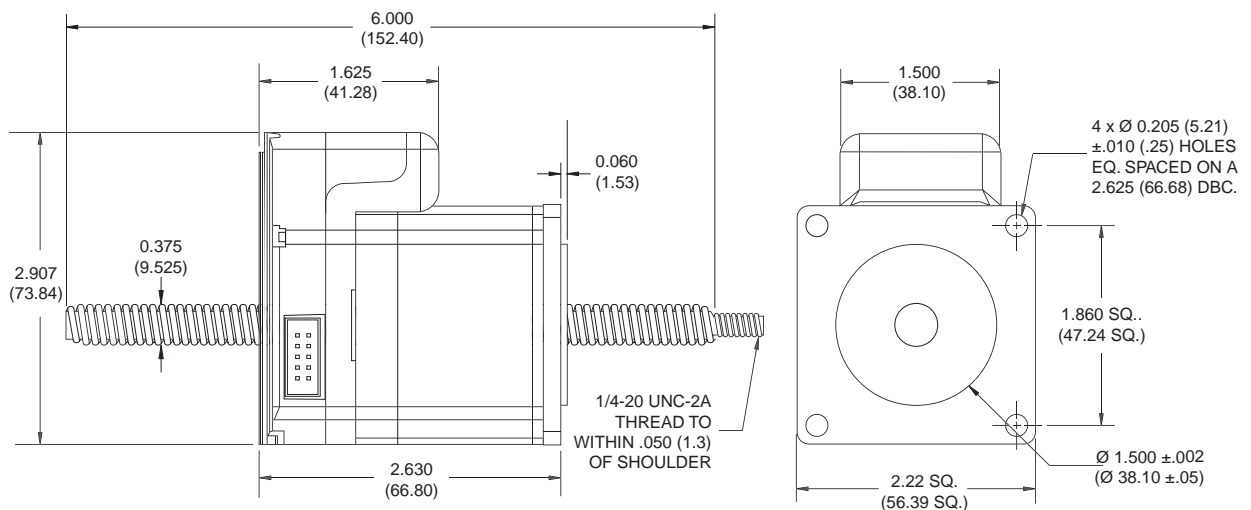

Figure 1.10: Linear Actuator MDrive23 Motion Control Mechanical Specifications

Linear Actuator MDrive Motion Control 2218 Specs and Speed-Force Curves

MDI23 Linear Actuator	
Maximum Thrust lbs (kg)	200 (90.7)
Maximum Screw Deflection	±1°
Backlash inches (mm)	0.005 (0.127)
Weight (Motor+Driver) oz (gm)	20.4 (578.3)

Table 1.7: Linear Actuator MDrive23 Motion Control Motor Specifications

Speed-Force Curve: 24 VDC

Refer to Table 1.8 for screw pitch information

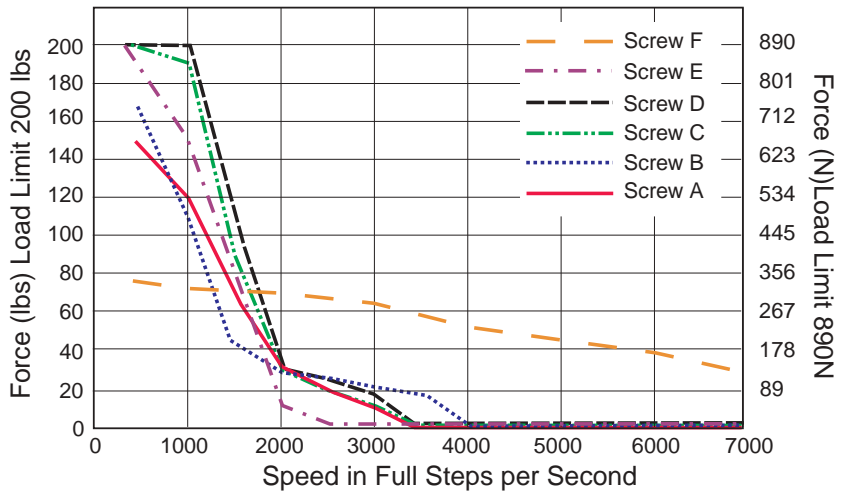

Figure 1.11: Speed-Force Curve - 24VDC (100% Current)

Speed-Force Curve: 45 VDC

Refer to Table 1.8 for screw pitch information

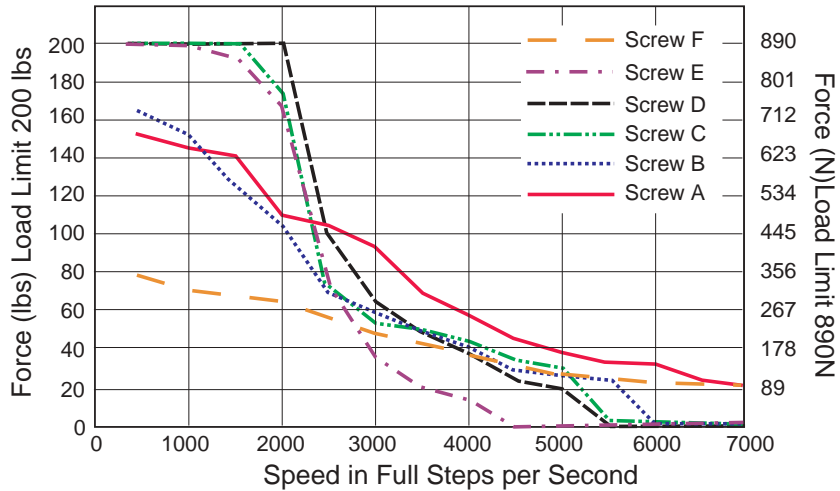

Figure 1.12: Speed-Force Curve - 45VDC (100% Current)

Acceleration/Deceleration

Range	1.5 x 10 ⁹ Steps per Second ²
Resolution	90.9 Steps per Second ²

Software

Program and Data Storage	Non-Volatile
User Program Space	767 Bytes
User Registers	4, 32 Bit
User Program Labels and Variables	22
Math, Logic AND Conditional Functions	+, -, x, ÷, <, >, =, <=, >=, & (AND), (OR), ^ (XOR), ! (NOT)
Branch Functions	Branch & Call (Conditional)

Predefined I/O Functions

Inputs	Home, Limit +, Limit -, Go, Soft Stop, Pause, Jog +, Jog -, Analog Input
Outputs	Moving, Fault
Trip Functions	Input, Position
Party Mode Node Addresses	62
Encoder Functions	Stall Detect, Position Maintenance, Find Index7

Power Supply Requirements

Each MDrive23 Motion Control will require a **maximum power supply current of 2A**. Actual power supply current will depend upon the load and duty cycle.

	WARNING:	<ul style="list-style-type: none">• DO NOT connect or disconnect power leads when power is applied!• Disconnect the AC power side to power down the DC power supply.• For battery operated systems, connect a "transient suppressor" across the power switch to prevent arcs and high voltage spikes.
--	-----------------	---

Recommended IMS Power Supplies

For the MDrive23 Motion Control, below are the recommended IMS power supplies.

IP404 Unregulated Linear Supply

Input Range	
120 VAC Versions	102-132 VAC
240 VAC Versions	204-264 VAC
Output	
No Load Output Voltage*	43 VDC @ 0 Amps
Continuous Output Rating*	32 VDC @ 2 Amps
Peak Output Rating*	26 VDC @ 4 Amps

ISP200-4 Unregulated Linear Supply

Input Range	
120 VAC Versions	102-132 VAC
240 VAC Versions	204-264 VAC
Output	
No Load Output Voltage*	41 VDC @ 0 Amps
Continuous Output Rating*	38 VDC @ 1.5 Amps
Peak Output Rating*	35 VDC @ 3 Amps

* All measurements were taken at 25°C, 120 VAC, 60 Hz.

	WARNING! The maximum +48 VDC Input Voltage of the MDrive23 includes Motor Back EMF, Power Supply Ripple and High Line.
---	---

Thermal Specifications

Because the MDrive consists of two core components, a drive and a motor, close attention must be paid to the thermal environment where the device is used. The following maximum temperatures apply to the MDrive23:

Heatsink Temperature - Max	85°C
Motor Temperature - Max	100°C

Section 1.5

Introduction to the MDrive34 Motion Control

Introduction to the MDrive34 Motion Control

The MDrive34 Motion Control offers the system designer a low-cost, intelligent motion controller integrated with a NEMA 34 high torque stepping motor and a +24 to +75 VDC microstepping drive.

The MDrive34 Motion Control adds a versatile array of functions by combining a complete programmable motion controller with our already compact and cost effective standard MDrive34, adding little cost and no increase in size. Standard offerings include four +5V logic to +24V logic programmable I/O points, one 10-bit 0 to 5 volt analog input, 0 to 5 MHz step clock rate, microstep resolution up to 51,200 steps per revolution and a full featured easy-to-program instruction set.

The MDrive34 Motion Control communicates using the RS-485 communications protocol, this allows for point-to-point or multi-drop communications using one communications port. Addressing and hardware support up to 62 MDrive nodes in a system. The communications BAUD rate is software selectable and ranges from 4.8 kbps to 115 kbps.

The MDrive34 is also available with an optional closed loop control. The closed loop configuration adds a 512 line (2048 count) internal magnetic rotary encoder with index mark without increasing the length of the unit. Closed loop configuration adds position maintenance, stall detection and find index mark.

Available motor configurations include a single shaft and a double shaft with control knob. Rotary versions are available in three motor lengths: 24, 31, & 47. Interface connections are accomplished with 12" flying leads.

Feature Summary

- Integrated Microstepping Drive/Motion Controller with Optional Encoder/NEMA 34 High Torque Stepping Motor
- +24 to +75VDC Input Voltage
- Low Cost
- Extremely Compact
- Available Configurations: Single Shaft, Integral Encoder, Knob for Manual Positioning
- Three Motor Stack Lengths Available
- Single Power Supply
- Microstep Resolution up to 51,200 Steps Per Revolution
- Open Loop or Optional Closed Loop Control
- Programmable Motor Run and Hold Current Settings
- Four 0V to 24V Inputs that work with +5V Logic (i.e. TTL, CMOS, etc.) or +24V Logic (i.e. PLC's)
- One Analog 10 Bit, 0 to 5 Volt Analog Input
- 0 to 5 MHz Step Clock Rate, Selectable in 0.59 Hz Increments
- RS-485 Communications Protocol
- Communications BAUD Rate Selectable from 4.8 kbps to 115 kbps
- 62 Software Addresses for Multidrop Communications
- Simple 1 and 2 Character Programming Instructions
- 12" Flying Lead Interface
- Optional Integrated RS-232 to RS-485 Converter/Communications Cable

Section 1.6

MDrive34 Motion Control Specifications

Section Overview

This section contains mechanical, motor and electrical specifications specific to each version of the MDrive34 Motion Control. Shown are:

- Rotary Motor Specifications
- General Specifications
- Power Supply Requirements
- Thermal Specifications

Rotary Motor Specifications

Mechanical Specifications - Dimensions in Inches (mm)

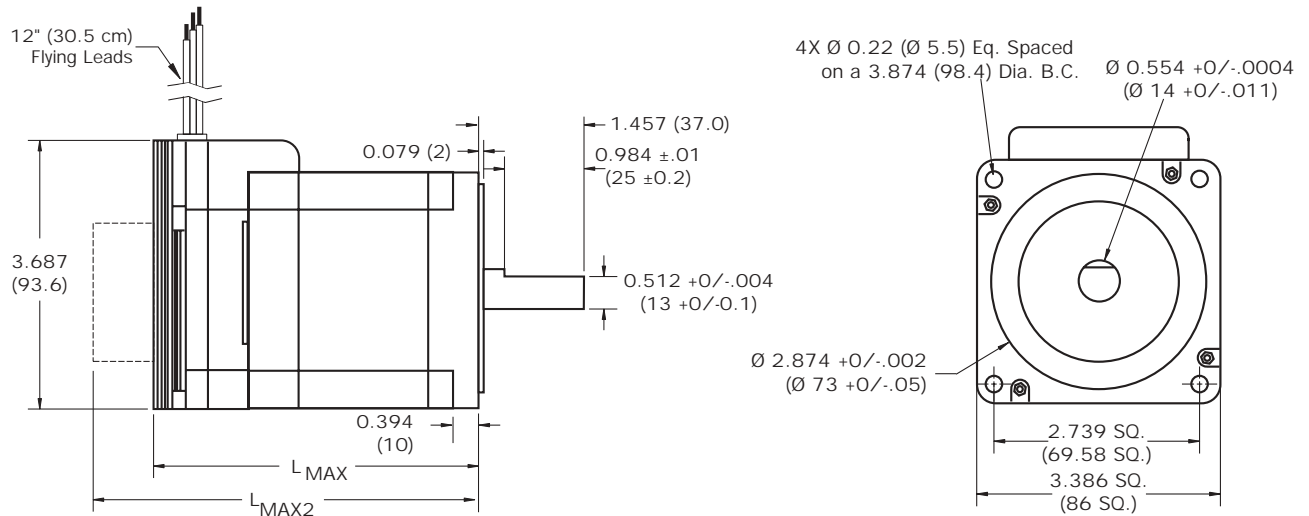

Standard Rotary Motor (L_{MAX})	
Stack	In (mm)
3424	3.973 (100.91)
3431	4.551 (115.60)
3447	6.073 (154.25)

Control Knob (L_{MAX2})	
Stack	In (mm)
3424	5.083 (129.10)
3431	5.661 (143.79)
3447	7.183 (182.44)

Figure 1.13: Rotary MDrive34 Motion Control Mechanical Specifications

MDrive Motion Control 3424 Motor Specs and Speed/Torque Curves

MDIF3424	
Holding Torque oz-in (N-cm)	381 (269)
Detent Torque oz-in (N-cm)	10.9 (7.7)
Rotor Inertia oz-in-sec ² (kg-cm ²)	0.01416 (1.0)
Weight (Motor+Driver) oz (gm)	51.1 (1450)

Table 1.9: Rotary MDIF3424 Motor Specifications

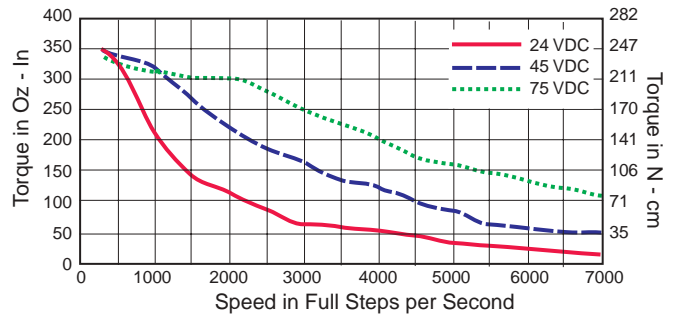

Figure 1.14: Rotary MDrive Motion Control 3424 Speed/Torque Data

MDrive Motion Control 3431 Motor Specs and Speed/Torque Curves

MDIF3431	
Holding Torque oz-in (N-cm)	575 (406)
Detent Torque oz-in (N-cm)	14.16 (10.0)
Rotor Inertia oz-in-sec ² (kg-cm ²)	0.02266 (1.6)
Weight (Motor+Driver) oz (gm)	72.3 (2050)

Table 1.10: Rotary MDIF3431 Motor Specifications

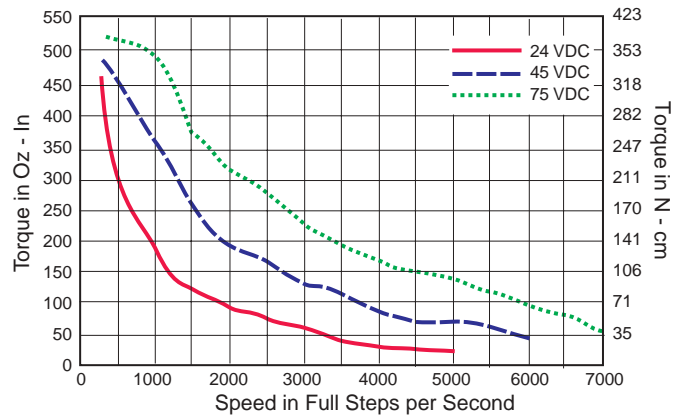

Figure 1.15: Rotary MDrive Motion Control 3431 Speed/Torque Data

MDrive Motion Control 3447 Motor Specs and Speed/Torque Curves

MDIF3447	
Holding Torque oz-in (N-cm)	1061 (749)
Detent Torque oz-in (N-cm)	19.83 (14.0)
Rotor Inertia oz-in-sec ² (kg-cm ²)	0.04815 (3.4)
Weight (Motor+Driver) oz (gm)	128.7 (3650)

Table 1.11: Rotary MDIF3447 Motor Specifications

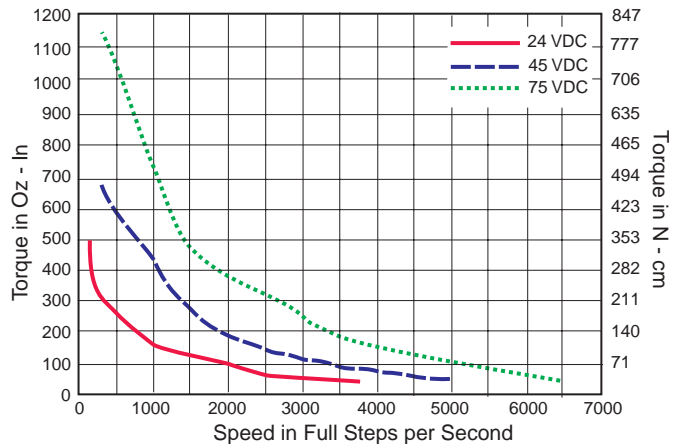
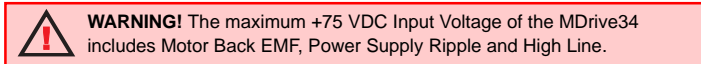

Figure 1.16: Rotary MDrive Motion Control 3447 Speed/Torque Data

General Specifications - MDrive34 Motion Control

Input Voltage (+V)

Range +24 to +75 VDC



A characteristic of all motors is back EMF. Back EMF is a source of current that can push the output of a power supply beyond the maximum operating voltage of the driver. As a result, damage to the stepper driver could occur over a period of time. Care should be taken so that the back EMF does not exceed the maximum input voltage rating of the MDrive34.

Analog Input

Resolution 10 Bit
 Voltage Range 0 to +5 Volts
 Current Range 4 - 20 mA

Programmable I/O

Number 4
 Interface Type Open Collector
 Logic Threshold
 Logic 0 <0.8VDC
 Logic 1 >2.2VDC
 Output Sink Current 700 mA
 Protection Over Temp., Short Circuit, Inductive Clamp

Communication

Protocol RS-485, Full/Half Duplex Selectable
 BAUD Rate 4800, 9600, 19.2k, 38.4k, 115.2k

Motion

Microstep Resolution – Open Loop Configuration

Number of Settings 14
 Steps per Revolution 400, 800, 1000, 1600, 2000, 3200, 5000 6400, 10000, 12800, 25000, 25600, 50000 51200

Microstep Resolution – Closed Loop Configuration (Optional)

Steps per Revolution (Fixed) 51200

Encoder (Optional)

Type Internal, Magnetic
 Resolution 512 Lines/2048 counts per Revolution

Counters

Type Position(C1), Encoder (C2)
 Resolution 32 Bit
 Edge Rate (Max) 5 MHz

Velocity

Range ±5,000,000 Steps per Second
 Resolution 1 Step per Second

Acceleration/Deceleration

Range 1.5 x 10⁹ Steps per Second²
 Resolution 90.9 Steps per Second²

Software

Program and Data Storage	Non-Volatile
User Program Space	767 Bytes
User Registers	4, 32 Bit
User Program Labels and Variables	22
Math, Logic ANd Conditional Functions Functions	+, -, x, ÷, <, >, =, <=, >=, & (AND), (OR), ^ (XOR), ! (NOT)
Branch Functions	Branch & Call (Conditional)

Predefined I/O Functions

Inputs	Home, Limit +, Limit -, Go, Soft Stop, Pause, Jog +, Jog -, Analog Input
Outputs	Moving, Fault
Trip Functions	Input, Position
Party Mode Node Addresses	62
Encoder Functions	Stall Detect, Position Maintenance, Find Index

Protection

Types	Over Voltage
-------------	--------------

Power Supply Requirements

Each MDrive34 Motion Control will require a **maximum power supply current of 4A**. Actual power supply current will depend upon the load and duty cycle.

**WARNING:**

- DO NOT connect or disconnect power leads when power is applied!
- Disconnect the AC power side to power down the DC power supply.
- For battery operated systems, connect a “transient suppressor” across the power switch to prevent arcs and high voltage spikes.

Recommended IMS Power Supplies

For the MDrive34 Motion Control, below are the recommended IMS power supplies.

IP804 Unregulated Linear Supply

Input Range

120 VAC Versions	102-132 VAC
240 VAC Versions	204-264 VAC

Output

No Load Output Voltage*	76 VDC @ 0 Amps
Continuous Output Rating*	68 VDC @ 3 Amps
Peak Output Rating*	64 VDC @ 6 Amps

ISP300-7 Unregulated Linear Supply

Input Range

120 VAC Versions	102-132 VAC
240 VAC Versions	204-264 VAC

Output

No Load Output Voltage*	68 VDC @ 0 Amps
Continuous Output Rating*	63 VDC @ 2 Amps
Peak Output Rating*	59 VDC @ 4 Amps

* All measurements were taken at 25°C, 120 VAC, 60 Hz.



WARNING! The maximum +75 VDC Input Voltage of the MDrive34 includes Motor Back EMF, Power Supply Ripple and High Line.

Thermal Specifications

Because the MDrive consists of two core components, a drive and a motor, close attention must be paid to the thermal environment where the device is used. The following maximum temperatures apply to the MDrive34:

Heatsink Temperature - Max	85°C
Motor Temperature - Max	100°C

Part 2: Connecting, Configuring and Programming the MDrive Motion Control

Section 2.1

Interfacing the MDrive Motion Control

Section Overview

This section will acquaint the user with connecting and using the MDrive Motion Control.

- Layout and Interface Guidelines
- Pin Configuration and Descriptions
- Interfacing Power
- Interfacing RS-485 Communications
- Interfacing Digital I/O
- Interfacing Analog Input

Layout and Interface Guidelines

Logic level cables must not run parallel to power cables. Power cables will introduce noise into the logic level cables and make your system unreliable.

Logic level cables must be shielded to reduce the chance of EMI induced noise. The shield needs to be grounded at the signal source to earth. The other end of the shield must not be tied to anything, but allowed to float. This allows the shield to act as a drain.

Power supply leads to the driver need to be twisted. If more than one driver is to be connected to the same power supply, run separate power and ground leads from the supply to each driver.

Recommended Wiring

The following wiring/cabbling is recommended for use with the MDrive Motion Control:

Power and Ground

MDI17 and MDI23	20 AWG
MDI34	18 AWG

Logic Wiring (I/O, Communications)

Wire Size	22 AWG
-----------------	--------

General Practices

The following wire strip length is recommended:

Wire Strip Length	0.250" (6.0 mm)
-------------------------	-----------------

Pin Configuration and Descriptions

MDrive Motion Control Connector P1 / Flying Leads			
Pin #	Flying Lead	Wire Size	Function and Description
1	White/Yellow	AWG 22	Open Collector I/O Point #1, +5 to +24 VDC
2	White/Orange	AWG 22	Open Collector I/O Point #2, +5 to +24 VDC
3	White/Violet	AWG 22	Open Collector I/O Point #3, +5 to +24 VDC
4	White/Blue	AWG 22	Open Collector I/O Point #4, +5 to +24 VDC
5	Green	AWG 22	10-Bit, 0 to +5V Analog Input
6	Black	AWG 20	Power Ground (Return) MDI17 and MDI23
		AWG 18	Power Ground (Return) MDI34
7	Red	AWG 20	+V: +12 to +48 VDC - MDI17 and MDI23
		AWG 18	+V: +24 to +75 VDC MDI34

Table 2.1: P1 Pin Configuration and Description

NOTE: Wire and insulation type are subject to the user's application and environment.

MDI Connector P2			
Pin #	Pin Name	Wire Size	Description
1-5	N/C		Reserved
6	RX +	AWG 22	RS-485 Receive +
7	RX -	AWG 22	RS-485 Receive -
8	TX -	AWG 22	RS-485 Receive -
9	TX +	AWG 22	RS-485 Receive +
10	GND	AWG 22	Communications Ground

Table 2.2: P2 Pin Configuration and Description

NOTE: Wire and insulation type are subject to the user's application and environment.

Interfacing Power

An advantage of the MDrive Motion Control is that only a single unregulated linear or unregulated switching power supply is required to power the control circuitry and motor power.

A maximum of:

2A output MDI17 and MDI23

4A output MDI34

is required from the supply for each MDrive. Note that the actual power required will be based upon the load and duty cycle.

Wiring should be accomplished using shielded twisted pair of appropriately gauged wires (see previous page). The shield should be attached to earth at the power supply end and left floating at the MDrive end.

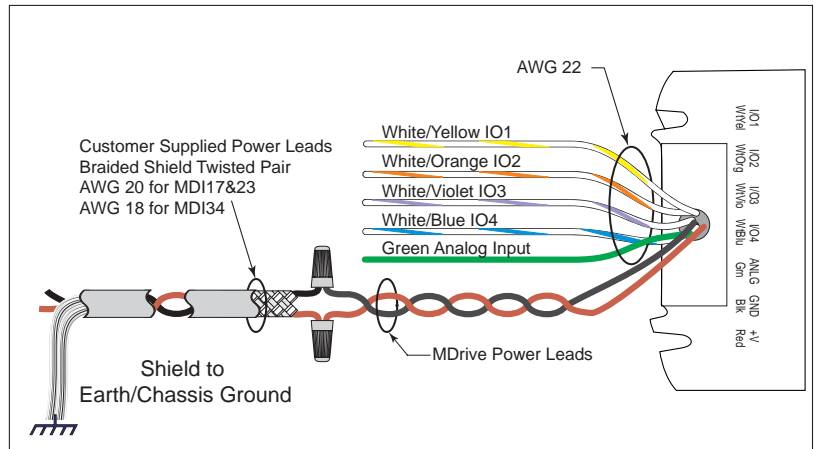

All MDrives are available with 12" Flying Leads. The Power Leads must be a shielded, twisted pair. AWG 18 for MDrive34, AWG 20 for MDrive17 & 23.

Figure 2.1: Power Supply Interface

Securing MDrive Power Leads and Logic Leads

Some applications may require that the MDrive move with the axis motion. If this is a requirement of your application, the motor leads (pluggable or flying) must be properly anchored. This will prevent flexing and tugging which can cause damage at critical connection points in the MDrive electronics.

DO NOT bundle the Logic Leads with the Power Leads.

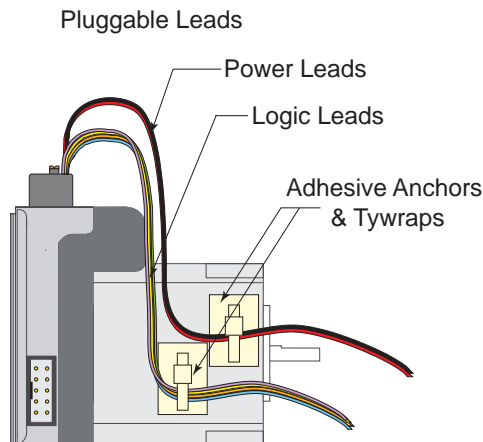

Figure 2.2 Typical MDrive with Pluggable Leads Secured

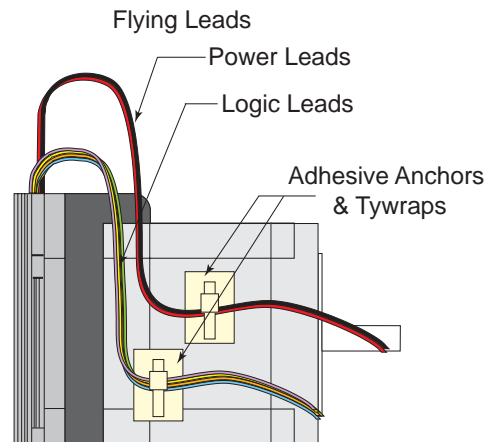

Figure 2.3 Typical MDrive with Flying Leads Secured

Interfacing RS-485 Communications

The MDrive Motion Control communicates to the host using the RS-485 protocol. Communications may be configured as either half or full duplex using the EM (Echo Mode) Instruction. RS-485 may be used in two ways: either to communicate to a single MDrive Motion Control, or to address up to 62 individually named MDrive nodes in a multidrop system.

Single MDrive

Optionally available for the MDrive Motion Control is a communications cable, IMS P/N MD-CC200-000, which has built-in RS-232 to RS-485 conversion circuitry. This will allow you to connect the serial port of your PC* directly to the MDrive Motion Control.

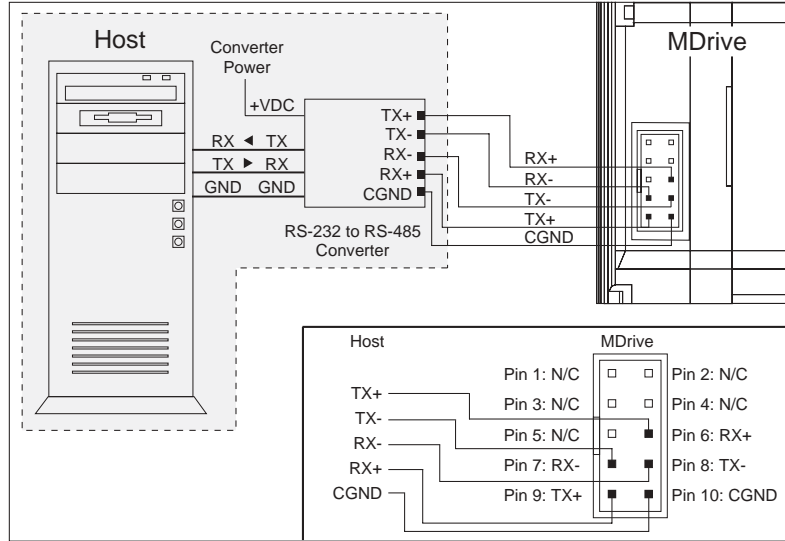

Figure 2.4: RS-485 Interface, Single MDrive Motion Control

NOTE: Termination resistors may be required on the Data Cables. (Please see Next Page.)

RS-485 2 Wire Communication

The MDrive Motion Control can be operated in a 2 wire RS-485 communication bus. Before connecting the 2 wire RS-485, download your program and setup instructions using the standard 4 wire RS-485 Communications Cable. If a program is not being used, download and save any setup parameters. To ensure the MDrive responds only to commands specifically meant for it, set the MDrive in Party Mode (Please see Party Mode on Page 25). The Echo Mode command (EM) must be set to the value of 1 (EM=1). This will set the MDrive communication into “half duplex” mode. Connect the MDrive in the 2 wire RS-485 configuration.

The following diagram illustrates how to connect the MDrive 4 wire RS-485 to operate as a 2 wire system.

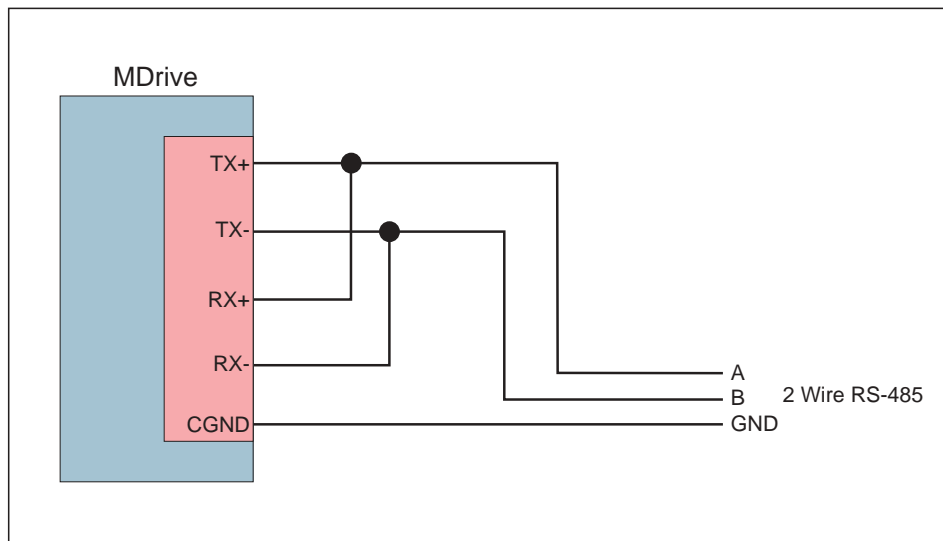

Figure 2.5: RS-485 2 Wire Communications (Half Duplex)

NOTE: The RS-232 to RS-485 cable, Part # MDCC-200-000 cannot be used in a 2 wire RS-485 system. If you wish to monitor the MDrive serial communication from a PC, an RS-232 to RS-485 2 wire converter must be used. This will allow you to monitor the MDrive.

Multiple MDrive Motion Control System (Party Mode)

In systems with multiple controllers it is necessary to communicate with the control modules using party mode (PY=1) of operation. The MDrive Motion Control nodes in the system are configured in software for this mode of operation by setting the Party Flag (PY) to True (1). It is necessary for all of the nodes in a system to have this configuration selected. When operating in party mode each MDrive Motion Control in the system will need a unique address, or name, to identify it in the system. This is accomplished by using the software command DN, or Device Name. For example, to set the name of an MDrive to "A" you would use the following command: DN=65 or DN="A" (65 is the ASCII decimal equivalent of uppercase A). The factory default name is "!". The asterisk character "*" is used to issue global commands to every device in the system. NOTE: When using the asterisk "*" in Party Mode, typed entries and commands will not be echoed. See Appendix A for ASCII table.

In setting up your system for party operation, the most practical approach is to observe the following steps:

1. Connect the first MDrive Motion Control to the Host PC configured for Single Mode Operation.
2. Establish communications and download program if required.
3. Using the command DN, name the MDrive Motion Control. This can be any upper or lower case ASCII character or number 0-9. (DN="A"{enter}) (Note: The parentheses before and after the device name are required.)
4. Set the party flag PY=1{enter}.
5. Press CTRL+J to activate the Party Mode.
6. Type the letters **AS** and press CTRL+J (Save device name and Party Mode).
7. Remove power.
8. Repeat steps 1 through 7 for each additional MDrive in the system.
9. After all MDrives are assigned a Device Name the Multiple MDrive Interface can be configured as shown below.

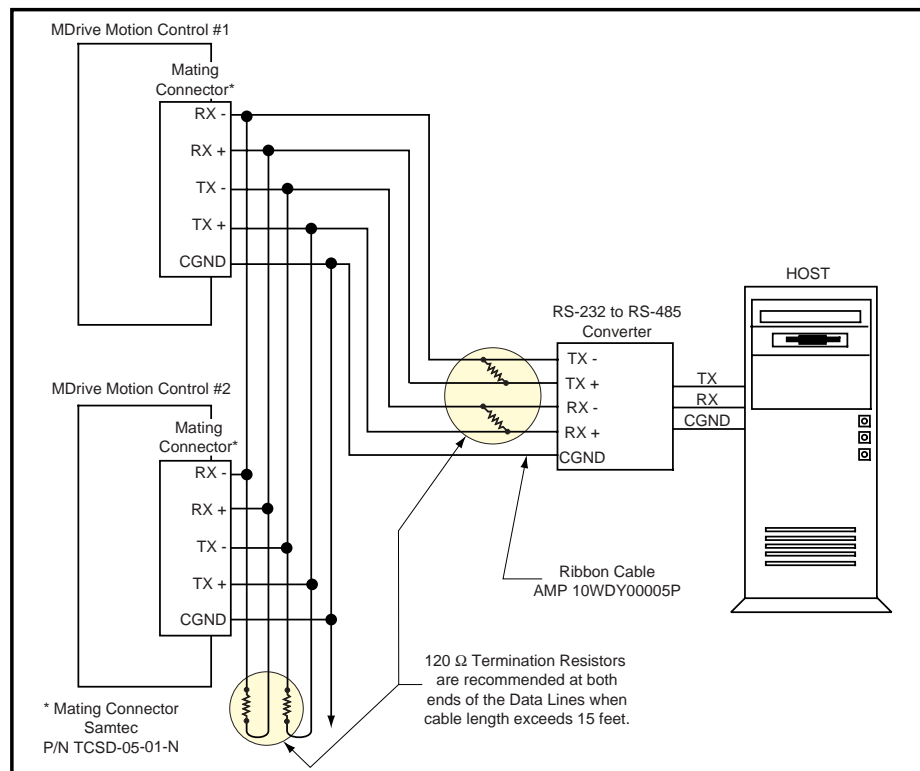

Figure 2.6: RS-485 Interface, Multiple MDrive Motion Control System

Data Cable Termination Resistors

Data Cable lengths greater than 15 feet (4.5 meters) are susceptible to signal reflection and/or noise. IMS recommends 120Ω termination resistors at both ends of the Data Cables. An example of resistor placement is shown in Figure 2.6. For systems with Data Cables 15 feet (4.5 meters) or less, the termination resistors are generally not required.

MDI Communication Format

The following communication formats used by MDrive Motion Control (MDI) units, began with firmware version 1.043.

{ } The contents between the { } symbols are transmitted.

{0D} Hex equivalent for a CR (Carriage Return).

{0A} Hex equivalent for a LF (Line Feed).

{DN} Represents the Device Name being sent.

{CS} Check Sum; {ACK} 06 Hex; {NAK} 15 Hex

EM = Echo Mode; PY = PartY Mode; CK= ChecK sum

The word {command} represents the immediate command sent to the MDI.

Command Execution Time (CET) is the time the MDI takes to execute a command. This varies from command to command and usually is in the 1-5 millisecond range.

MDI Response to Echo Mode

Dependent on how the Echo Mode is set in conjunction with Party Mode and Check Sum, the MDI will respond differently. The following tables illustrate the various responses based on how the EM, PY and CK parameters are set.

Parameter Setting	Transmission to MDI	MDI Initial Response	MDI Final Response	Notes
EM=0 & PY=0 CK=0	{command}{D}	{command} (echoed back one character at a time as the character is entered)	CET {0D} {0A} >	The last character sent is the prompt >
EM=1 & PY=0 CK=0	{command} {0D}		CET {0D} {0A}	The last character sent is the LF
EM=2 & PY=0 CK=0	{command} {0D}			No response except to PR and L commands
EM=3 & PY=0 CK=0	{command} {0D}		CET command {0D} {0A}	Queued response. The last character sent is the LF

Table 2.3: MDI Response to Echo Mode when Party and Check Sum are Zero (0)

Parameter Setting	Transmission to MDI	MDI Initial Response	MDI Final Response	Notes
EM=0 & PY=1 CK=0	{DN} {command} {0A}	{command} (echoed back one character at a time as the character is entered)	CET {0D} {0A} >	The last character sent is the prompt >
EM=1 & PY=1 CK=0	{DN} {command} {0A}		CET {0D} {0A}	The last character sent is the LF
EM=2 & PY=1 CK=0	{DN} {command} {0A}			No response except to PR and L commands
EM=3 & PY=1 CK=0	{DN} {command} {0A}		CET command {0D} {0A}	Queued response. The last character sent is the LF

Table 2.4: MDI Response to Echo Mode when Party is One (1) and Check Sum is Zero (0)

Parameter Setting	Transmission to MDI	MDI Initial Response	MDI Final Response	Notes
EM=0 & PY=0 CK=1	{command} {CS} {0D}	{command} (echoed back one character at a time as the character is entered)	CET {ACK} or {NAK} >	The last character sent is the prompt >
EM=1 & PY=0 CK=1	{command} {CS} {0D}		CET {ACK} or {NAK}	The last character sent is ACK or NAK
EM=2 & PY=0 CK=1	{command} {CS} {0D}			No response except to PR and L commands
EM=3 & PY=0 CK=1	{command} {CS} {0D}		CET command {CS} {ACK} or {NAK}	Queued response. The last character sent is the ACK or NAK

Table 2.5: MDI Response to Echo Mode when Party is Zero (0) and Check Sum is One (1)

Parameter Setting	Transmission to MDI	MDI Initial Response	MDI Final Response	Notes
EM=0 & PY=1 CK=1	{DN} {command} {CS} {0A}	{command} (echoed back one character at a time as the character is entered)	CET {ACK} or {NAK} >	The last character sent is the prompt >
EM=1 & PY=1 CK=1	{DN} {command} {CS} {0A}		CET {ACK} or {NAK}	The last character sent is the ACK or NAK
EM=2 & PY=1 CK=1	{DN} {command} {CS} {0A}			No response except to PR and L commands
EM=3 & PY=1 CK=1	{DN} {command} {CS} {0A}		CET command {CS} {ACK} or {NAK}	Queued response. The last character sent is the ACK or NAK

Table 2.6: MDI Response to Echo Mode when Party and Check Sum are One (1)

Using Check Sum

For communication using Check Sum, the following 2 commands demonstrate sending and receiving.

Sending Command

1. Check Sum set to ZERO before first character is sent.
2. All characters (ASCII values) are added to Check Sum, including the Device Name DN (if PY=1), to the end of the command, but not including terminator.
3. Check Sum is 2's complement OR'd with Hex 80 (prevents Check Sum from being seen as Command Terminator).
4. Terminator Sent.

Example command:

```
MR (space) 1
77 82 32 49   Decimal value
4D 52 20 31   Hex
77+82+32+49=240   Add decimal values together
1111 0000 240   Change 240 decimal to binary
0000 1111      1's complement
0001 0000      Add 1 [2's complement]
1000 0000      OR result with 128
1001 000 144   Result Check Sum value
```

Once the result is reached, add the check Sum value of 144 to your string by typing: MR 1(Alt Key + 0144) (use the symbol of 144 in your string by holding down the alt key and typing 0144).

Receiving Command

1. Check Sum set to ZERO.
2. All characters are added to Check Sum.
3. When receiving a Command Terminator, the lower 7 bits of the Check Sum should be = to ZERO.
 - a) If not ZERO, then command is ignored and NAK echoed.
 - b) If ZERO, then ACK is sent instead of CR/LF pair.
4. Responses to PR commands will be Check Summed as above, but the receiving device should NOT respond with ACK or NAK.

MDrive Motion Control Party Mode Sample Codes

1. Download this segment of code into the first MDrive Motion Control. After downloading the program to the unit, follow the Set Up instructions described earlier. Be sure to set your first unit with the unique address of A (device name is case sensitive).

RC=25	'Run current
HC=5	'Hold current
MS=256	'Microstep selection
A=250000	'Acceleration
D=250000	'Deceleration
PG 1	'Enter program mode
S1=0,0	'Setup I/O 1 as an input low true
LB SU	'Start program upon power up
LB AA	'Label program AA
MR 104400	'Move relative 104400 counts
H	'Hold program execution to complete the move
LB DD	'Label program DD
BR DD,I1=0	'Branch to DD if I1=0
PR "Bex 1"	'Print device name B to execute program at address 1
H 2000	'Hold program execution 2000 milliseconds
PR "Cex 1"	'Print device name C to execute program at address 1
H 2000	'Hold program execution 2000 milliseconds
BR AA	'Branch to label AA
PG	'Exit program, return to immediate mode

2. Download this segment of code into your second MDrive Motion Control. After downloading the program to the unit, follow the previous party mode instructions. Be sure to set your second unit with the unique address of B (device name is case sensitive).

RC=25	'Run current
HC=5	'Hold current
MS=256	'Microstep selection
A=250000	'Acceleration
D=250000	'Deceleration
PG 1	'Enter program mode
LB BB	'Label program BB
MR 208000	'Move relative 208000 counts
H	'Hold program execution to complete the move
PG	'Exit program, return to immediate mode

- Download this segment of code into your third MDrive Motion Control. After downloading the program to the unit, follow the previous party mode instructions. Be sure to set your third unit with the unique address of C (device name is case sensitive).



RC=25	'Run current
HC=5	'Hold current
MS=256	'Microstep selection
A=250000	'Acceleration
D=250000	'Deceleration
PG 1	'Enter program mode
LB CC	'Label program CC
MR 300000	'Move relative 300000 counts
H	'Hold program execution to complete the move
PG	'Exit program, return to immediate mode

MDrive Motion Control Immediate Party Mode Sample Codes

Once Party Mode has been defined and set up as previously described under the heading "Multiple MDrive Motion Control System (Party Mode)", you may enter commands in the Immediate Mode in the IMS Terminal Window. Some examples follow.

Move MDrive A, B or C 10000 Steps

Assuming there are three MDrives set up in Party Mode as shown in the Sample Codes above.

NOTE: When instructed to type **CtrlJ**, that is the  key + the  key. It will not display in the Terminal Window so be certain you press the correct keys. **CtrlJ** activates the Party Mode.

The ^ symbol represents a space. Be certain to type a space where the ^ symbol indicates.

To move MDrive Unit "A", Press **CtrlJ** and then type: **AMR^10000** and press **CtrlJ**. MDrive Unit "A" will move 10000 steps.

NOTE: Once you have activated Party Mode with the first **CtrlJ** you do not have to type it before each successive command. However, every command must be followed with a **CtrlJ**.

To print the position type: **APR^P** and press **CtrlJ**. The position of MDrive Unit "A" will be printed.

To move MDrive Unit "B" type: **BMR^10000** and press **CtrlJ**. MDrive Unit "B" will move 10000 steps.

To move all three MDrives at the same time type: ***MR^10000** and press **CtrlJ**. All MDrives will move 10000 steps.

NOTE: The asterisk (*) is a global command which addresses all units. Since three units can not answer together, the asterisk (*) as well as other global commands will not be displayed in the Terminal Window.

To change a Variable in the "C" unit type: **C<variable name><number>** and press **CtrlJ**. The variable will be changed.

To verify the change type: **CPR^<variable name>** and press **CtrlJ**. The new value will be displayed.

All Commands and Variables may be programmed in this manner.

To take an MDrive out of Party Mode type: **<device name>PY=0** and press **CtrlJ**. That unit will be taken out of Party Mode.

To take all units out of Party Mode type: ***PY=0** and press **CtrlJ**. All units will be taken out of Party Mode.

Interfacing the Digital I/O

The MDrive Motion Control comes standard with a set of four (4) open collector +5 to +24VDC I/O point which may be programmed individually as either general purpose or dedicated inputs or outputs, or collectively as a group.

The digital I/O may be defined as either active HIGH or active LOW. When the I/O is configured as active HIGH, the level is +5 to +24 VDC and the state will be read/set as a “1”. If the level is 0 VDC then the state will be read/set as “0”. Inversely, if configured as active LOW, then the state of the I/O will be read/set as a “1” when the level is LOW, and a “0” when the level is HIGH. The active HIGH/LOW state is configured by the third parameter of the I/O Setup (S1-4) variable, which is explained further on. The goal of this I/O configuration scheme is to maximize compatibility between the MDrive Motion Control and standard sensors and switches.

The MDrive Motion Control’s I/O scheme is a powerful tool for machine and process control.

Uses of the Digital I/O

The I/O may be utilized to receive input from external devices such as sensors, switches or PLC outputs. When configured as outputs, devices such as relays, solenoids, LED’s and PLC inputs may be controlled from the MDrive Motion Control.

Each I/O point may be individually programmed to any one of 9 dedicated input functions, 3 dedicated output functions, or as general purpose inputs or outputs. The I/O may be addressed individually, or as a group. The active state of the line or group may also be set. All of these possible functions are accomplished with of the I/O Setup Variable (S1-4).

Interfacing Inputs

The MDrive Motion Control inputs may be interfaced to a variety of sinking devices. A single input may be programmed to be a general purpose user input, or to one of nine dedicated input functions. These then may be programmed to have an active state of either HIGH or LOW.

Additionally the inputs may read as a group using the “IN” keyword. This will display as a decimal between 0 and 15 representing the 4 bit binary number. Used thus Input 1 is the Least Significant Bit (LSB) and Input 4 will be the Most Significant Bit (MSB).

Interfacing a Single Input Examples

Input Functions		
S1-S4	Function	Active
0	General Purpose	0/1
1	Home	0/1
2	Limit +	0/1
3	Limit -	0/1
4	G0	0/1
5	Soft Stop	0/1
6	Pause	0/1
7	Jog +	0/1
8	Jog -	0/1

Table 2.7: Input Functions

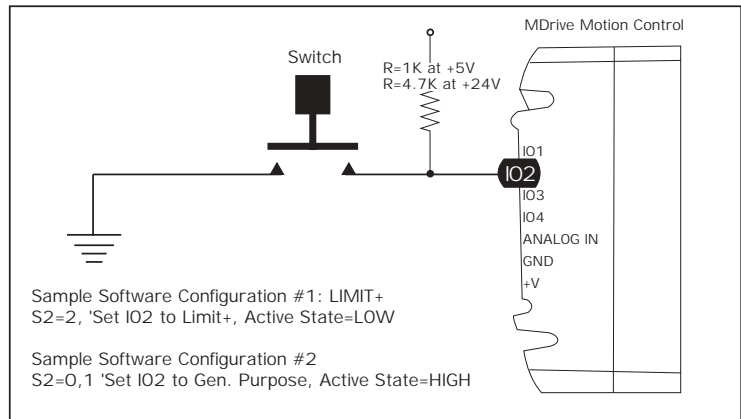

Figure 2.7: Input Interfaced to a Switch

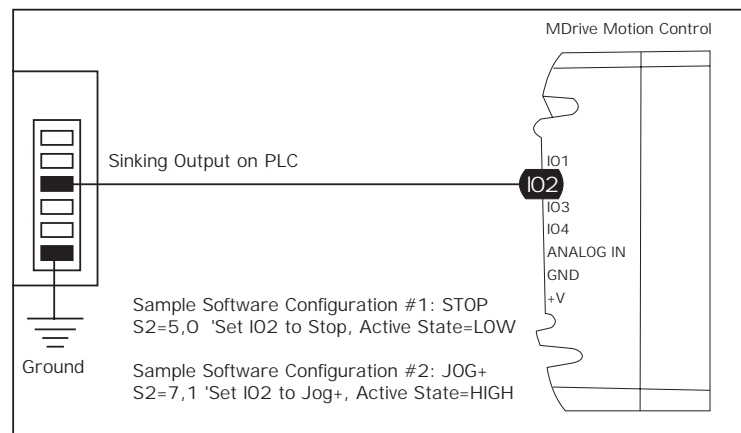

Figure 2.8: Input Interfaced to a PLC

Interfacing Inputs as a Group Example

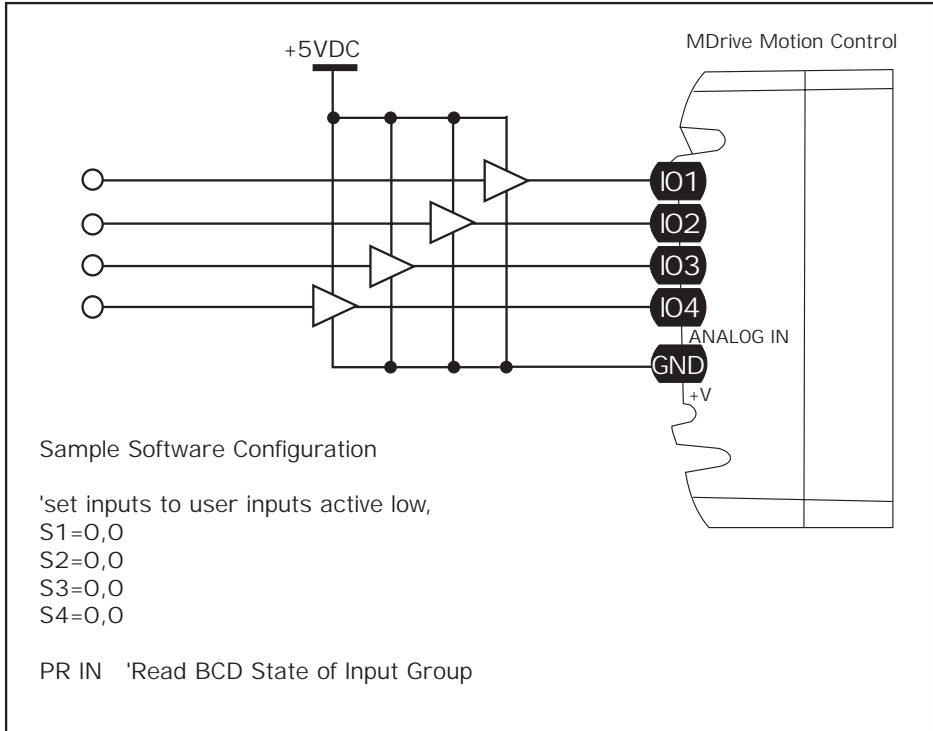

Figure 2.9: TTL Interface to Input Group

Truth Table - I/O Used as a Group				
DEC	IO4	IO3	IO2	IO1
0	0	0	0	0
1	0	0	0	1
2	0	0	1	0
3	0	0	1	1
4	0	1	0	0
5	0	1	0	1
6	0	1	1	0
7	0	1	1	1
8	1	0	0	0
9	1	0	0	1
10	1	0	1	0
11	1	0	1	1
12	1	1	0	0
13	1	1	0	1
14	1	1	1	0
15	1	1	1	1

Table 2.8: I/O Group Truth Table

Interfacing Outputs

The MDrive Motion Control Outputs may be configured as either general purpose or set to one of two dedicated functions, Fault or Moving. These outputs will sink up to 700 mA max and may be connected to +5 to +24VDC. Note that a current limiting resistor may be required to limit the current to 700 mA.

As with the inputs the MDrive Motion Control Outputs may be used singularly or collectively as a group.

Interfacing a Single Output Examples

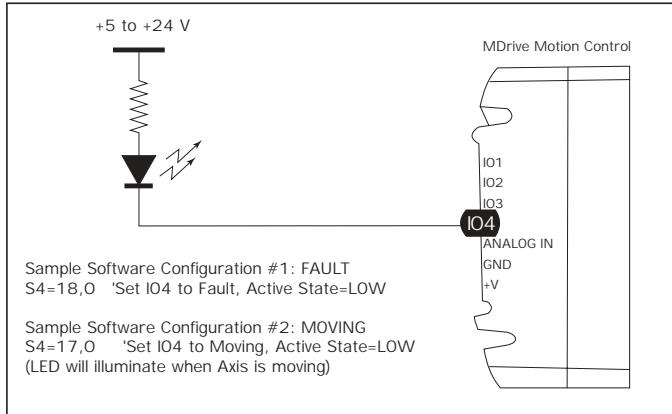

Figure 2.10: Output Interfaced to an LED

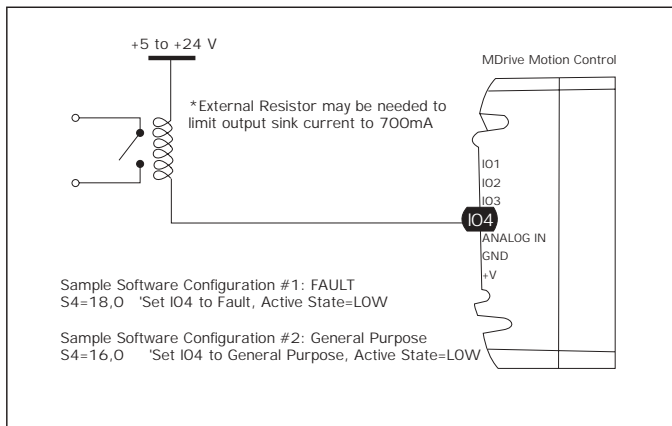

Figure 2.11: Output Interfaced to a Relay

Interfacing Outputs as a Group Example

To write to the outputs as a group the OT instruction is used. This will give you a binary output of 0000 to 1111 from a decimal entry of 0-15. Output 1 will be the Least Significant Bit (LSB), Output 4 will be the Most Significant Bit (MSB). See Table 2.4 for Truth Table.

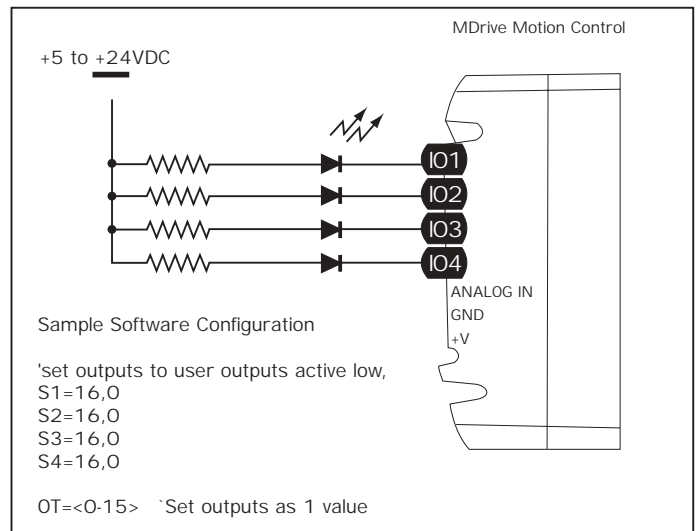

Figure 2.12: Outputs Interfaced to LED's as a Group

Output Functions		
S<point>=	Function	Active
16	General Purpose	0/1
17	Moving	0/1
18	Fault	0/1
19	Stall	0/1
20	Velocity Changing	0/1

Table 2.9: Output Functions

Interfacing the Analog Input

The analog input of the MDrive Motion Control is configured from the factory as a 0 to 5V, 10 bit resolution input (S5 = 9). This offers the user the ability to receive input from temperature, pressure or other forms of sensors, and then control events based upon the input.

The value of this input will be read using the I5 instruction, which has a range of 0 to 1024, where 0 = 0 volts and 1024 = 5.0 volts. You may then use the program branch (BR) or subroutine call (CL) instructions to control events within the system.

The MDrive Motion Control may also be configured for a 4 - 20 mA Analog Input (S5 = 10).

Sample Usage

```

*****Main Program*****

S5=9                'set analog input to read variable voltage (0 to +5VDC)
PG 100              'start prog. at address 100
LB A1               'label program A1
CL A2, I5<500       'Call Sub A2, If I5 is less than 500
CL A3, I5>524       'Call Sub A3, If I5 is greater than 524
BR A1               'loop to A1
E                   'End
PG                  'Exit program

*****Subroutines*****

LB A2               'label subroutine A2
MA 2000             'Move Absolute 2000 steps
H                   'Hold program execution until motion ceases
RT                  'return from subroutine

LB A3               'label subroutine A3
MA -2000            'Move Absolute -2000 steps
H                   'Hold program execution until motion ceases
RT                  'return from subroutine
    
```

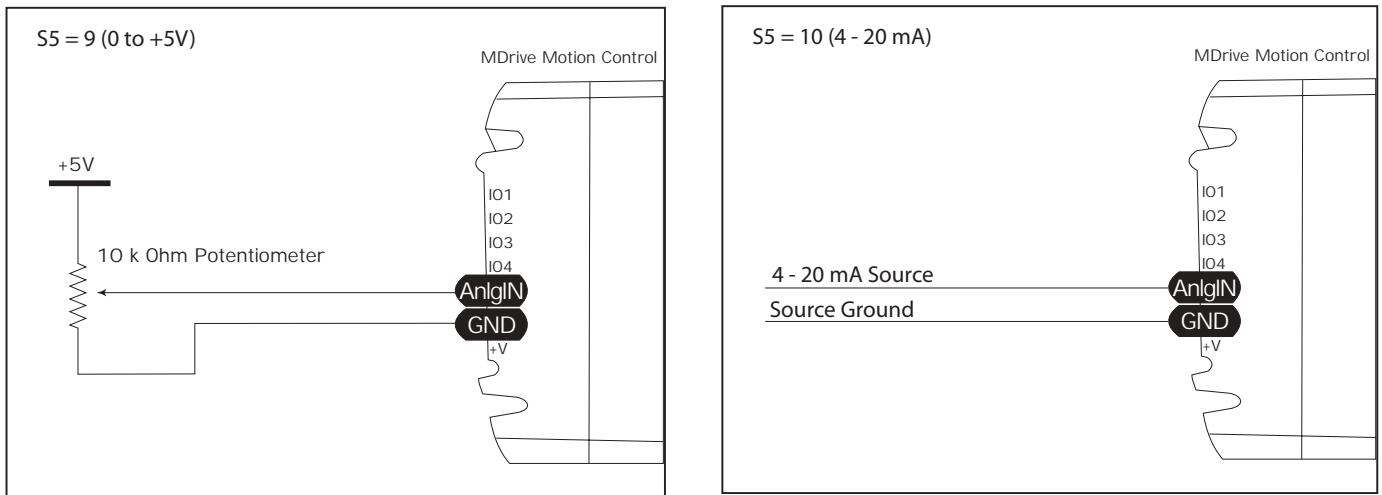

Figure 2.13: Analog Input Interface (0 to +5 VDC / 4 - 20 mA)

Section 2.2

MDrive Motion Control Software Introduction

Section Overview

This section will acquaint the user with basics of MDrive Motion Control Programming

- Installing IMS Terminal Software
- Upgrading the MDrive Firmware
- The MDrive Program

Installing and Using IMS Terminal

System Requirements

- IBM Compatible PC.
- Windows 9x (95/98) or Windows NT (Windows NT4.0 SP6, Windows 2000 SP1, Windows XP)
- 10 MB hard drive space.
- A free serial communications port.

Installation

The IMS Terminal software is a programming/communications interface. This program was created by IMS to simplify programming and upgrading the MDrive Motion Control. The IMS Terminal is also necessary to upgrade the firmware in your MDrive Motion Control. These updates will be posted to the IMS web site at www.imshome.com as they are made available.

To install the IMS Terminal to your hard drive, insert the IMS Product CD into your CD-ROM Drive. The CD should autostart to the IMS Main Index Page. If the CD does not autostart, click “Start > Run” and type “x:\IMS.exe” in the “Open” box and click OK.

NOTE: “x” is your CD ROM drive letter.

- 1) The IMS Main Index Page will be displayed.



Figure 2.14: IMS CD Main Index Page

- 2) Place your mouse pointer over the MDrive Icon. The text message “MDrive Integrated Motor & Electronics” will be displayed. This verifies you have selected the correct software.
- 3) Click the MDrive Motor Icon. This opens the MDrive Index Page.



Figure 2.15: IMS CD Software Selection Page

- 4) Place the mouse pointer over the menu and select IMS Terminal (Win9x) or IMS Terminal (WinNT). The displayed text will again verify your selection. Click your selection and the “Setup” dialog box will be displayed.



Figure 2.16: IMS CD Software Setup Command

- 5) Click SETUP in the Setup dialog box and follow the on-screen instructions. Once IMS Terminal is installed the Communications Settings can be checked and/or set.

Configuring Communications Settings

The communications settings are configured by means of the “Preferences Dialog Box”. The preferences dialog gives the user the ability to set the format for text size, font and color, as well as general communications settings. The optimum communications settings for the MDrive Motion Control are set by default. After the IMS Terminal Software is installed you may start it and perform the configuration.

- 1) Open the IMS Terminal by clicking Start>Programs>IMS Terminal>IMS Term.
- The following screen will be displayed.

The left window is the Program Editing Window. The right window is the IMS Terminal Window. Resident programs and immediate commands can be executed, stopped and tracked from the Terminal Window.

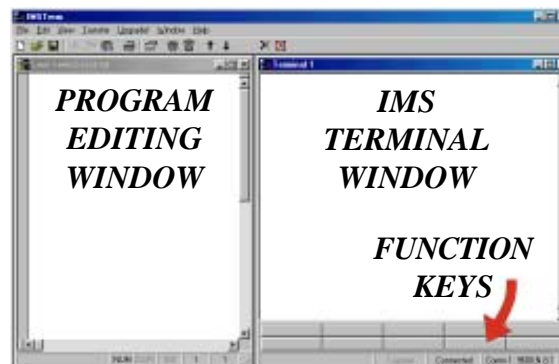



Figure 2.17: Main IMS Terminal Page

2) You must select or verify the Communications Port that you will be using with your MDrive.

- a) On the Menu Bar click <Edit> <Preferences> or click the Preferences Button  on the main Tool Bar to display the "Preferences" Dialog Box.

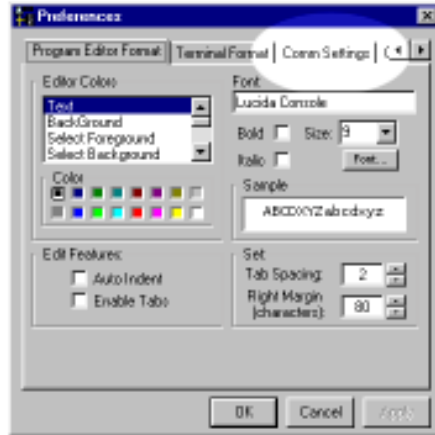

Figure 2.18: Preferences Dialog Box

- b) You may also display the Preferences Dialog Box by right clicking in the Terminal Window. A small dialog box will be displayed.

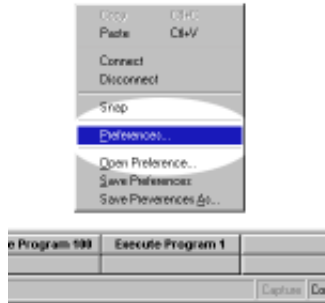

Figure 2.19: Preferences Selection Dialog Box in the Terminal Window

- c) Click “Preferences” in the small dialog box to display the Preferences Dialog Box. The Preferences Dialog Box allows you to select window colors and fonts for the Text Editing Window and Terminal Window as well as Communications Setup.

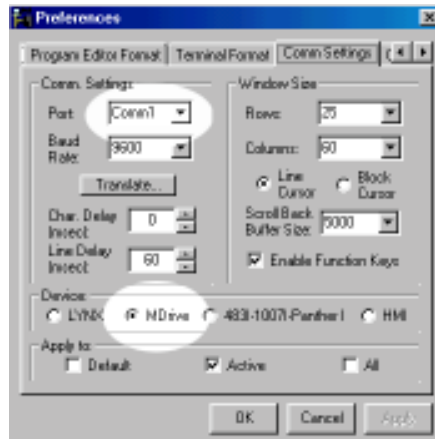

Figure 2.20: The Comm Settings Dialog Box

- d) Click the “Comm Settings” tab at the top of the dialog box. The Comm settings page will be displayed.
- e) Under “Device” near the bottom of the box verify “M Drive” is selected. The BAUD rate is already set to the MDrive default. Do not change this setting until you have established communications with the MDrive Motion Control. If you change the BAUD rate setting for the MDrive Motion Control, power will have to be cycled for the change to take effect. Ensure that the IMS Terminal preferences are adjusted for the new BAUD settings.
- f) Verify the Comm Port you are using.
- g) The “Window Size” settings are strictly optional. You may set these to whatever size is comfortable to you.
- h) Click “APPLY” and “OK”. The settings will be saved automatically.

3) Verify all connections are made and apply power to the MDrive. The following sign-on message should appear in the Terminal window: "Copyright 2001-2003 by Intelligent Motion Systems, Inc."



Figure 2.21: Copyright Statement in Terminal Window

If you can see this sign-on message then you are up and running! If the sign-on message does not appear, try using a software reset. Hold down the "Ctrl" key and press "C" (^C). If the sign-on message still does not appear then there may be a problem with either the connections, hardware or software configuration of the MDrive Motion Control or Host PC.

There are also indicators at the bottom of the page (See Figure 2.21) that show whether you are Connected or Disconnected, the current Baud Rate and the type of device (MDrive) for which the IMS Terminal is configured. These three items may be changed directly from this screen by double clicking on them.

Double Click on "Connected" and the system will disconnect. Double Click on "Disconnect" and the system will connect.

Double Click on the Baud Rate and the preferences page will open so you can change it.

Double Click on the "MDrive" and the preferences page will open with the option to change the drive. (For this application you would not change the MDrive.)

Using the IMS Terminal Software

The IMS Terminal software is an easy to setup and use interface for MDrive Motion Control programming. It is also required to upgrade the firmware in the MDrive Motion Control.



Many of the commands you will be using work in both the Program Editor Window and the Terminal Window. You must have the proper window selected before activating the command.

IMS Terminal Tool Bar

The IMS Terminal Tool Bar is configured with all the necessary functions to operate IMS Terminal.

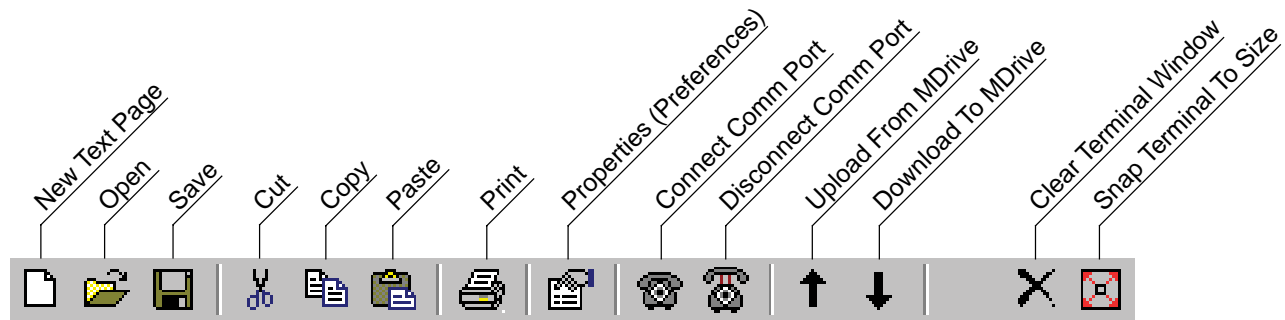

Figure 2.22: The IMS Terminal Tool Bar

Creating, Downloading and Uploading Programs

Existing programs may be edited in the Program Editor Window from a file on a disk, a file on the hard drive or a file uploaded from the MDrive. You may also create a new program in the Program Editor Window.

NOTE: Your system must be connected and running and perform these steps as they are outlined.

Creating a New Program

Before you create a program you must have a new Program Editor Window open. Follow these steps:

- 1) Click on the Drop-Down Menu “View”. The following dialog box will be displayed:



Figure 2.23: Drop-Down Menu for New Edit Window

- 2) Click on “New Edit Window”. The following dialog box will be displayed:



Figure 2.24: Naming the New Program/Program Editor Window

- 3) You must assign a file name in order to open the new window. If there is no file name the “OK” button will not be highlighted. Name this file <motion sample.mxt>. The <mxt> extension designates programs for the MDrive.
- 4) Click “OK” and the new Program Editor Window will be displayed.



Figure 2.25: New Program Editor Window Named “motion sample.mxt”

Naming the program with the <mxt> extension automatically formats the text color and makes most of the characters appear in upper case. When you type a program the text will be color coded. In complex programs it may be difficult to read the text easily. By formatting indents, the overall appearance and readability will be greatly improved.

Formatting the Program Text

To format the text for indents you need to call up the “Preferences” dialog box. Click the “Program Editor Format” tab at the top of the box. The screen shown below will be displayed. In the “Edit Features” block (See 1 below) click on the small box to the left of “Auto Indent” and verify there is a check mark (✓) in the box. This will enable Automatic Indents. Once you indent your text with the “Tab” key all subsequent lines will adopt the same indent. Simply backspace to return to the left margin. There is also an “Enable Tabs” option. If this box is checked, tabs will be inserted into your text. If the “Tabs” option is disabled, character spaces will be inserted. For this example the “Enable Tabs” will be turned off. In the “Set” block (See 2 below) you may also set the tab spacing. The default is 2 characters. When completed, click “Apply” and then click “OK”.

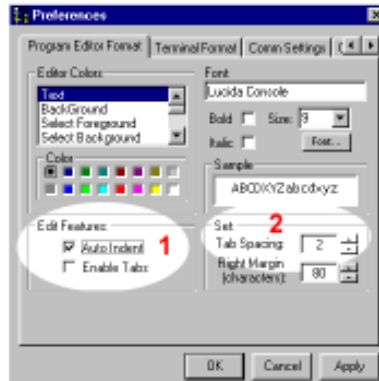

Figure 2.26: Program Editor Preferences

Now you can indent your text. Individual preference will govern how you set up your indents. The format illustrated below is most commonly used. All of the set Variables and Program Modes are left aligned. All the Labels are indented 2 characters or 1 tab. The remaining commands are indented 4 characters or 2 tabs. Indent your text by pressing the “Tab” key.

A program can now be typed into the new Program Editor Window. For this example we will use one of the sample programs found in Appendix C. The program is the first one. It is titled **Motion Sample**.

Type the program in as it is shown in Appendix C. You can type upper or lower case. Be sure to put all spaces in as they are indicated by the ^ symbol. It is not necessary to put in the comments but they are allowed in the program provided they begin with an apostrophe (^). NOTE: The total number of Characters and spaces must be limited to 64 per line.

As you type, the text will be automatically formatted and color coded for the MDrive. When you edit or type new commands they will appear black and will then be automatically changed to the proper color and case when you press “Enter”. If you type in all lower case characters, upon pressing “Enter” part or all of the text will be changed to upper case characters. This is an indicator that the syntax was correct and accepted by the IMS Terminal. If the entire command line is changed to red with no uppercase characters it is a bad command. Add tabs where they are desired. When complete, your program should resemble the example below. Be sure to SAVE YOUR PROGRAM by clicking “File>Save”.

NOTE: The indicator lines and labels are not part of the program. They have been added for illustration purposes only.

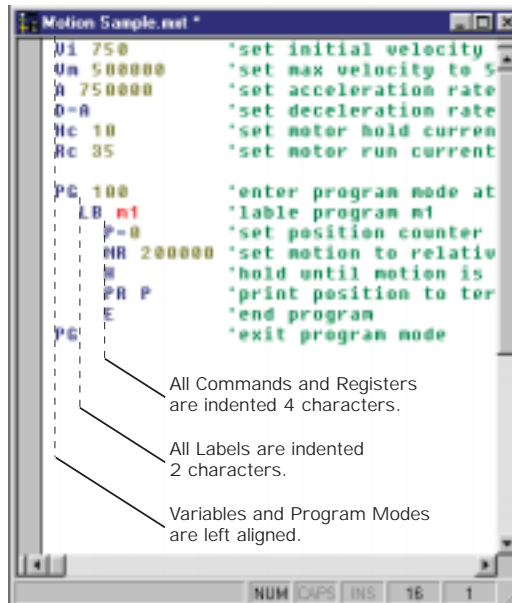

Figure 2.27: Example of Indented Text

In the illustration below the default color coding is Dark Blue, Light Blue, Red, Green, Olive and Brown. Their designations are:

- Dark Blue = Key Words
- One Upper/One Lower Case = IMS Variables or Flags
- All Upper Case = IMS Commands
- Light Blue = Numerical Signs
- Red = User Defined Data
- Green = Remarks
- Olive = Numerical Values
- Brown = Text Strings in Quotes (Not Shown)

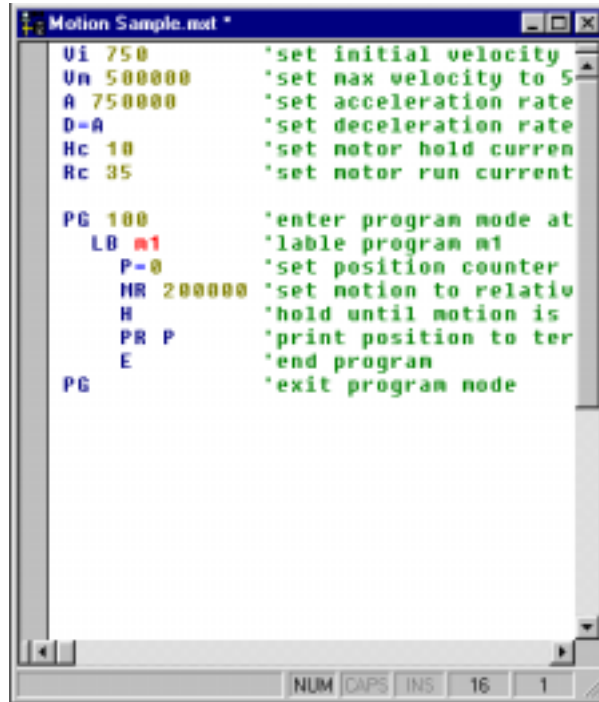

Figure 2.28: Formatted and Color Coded Program Text

The colors may be changed to suit the user's preference. To change the colors call up the "Preferences" page. Click on the "Program Editor Format" tab at the top of the page. In the "Edit Colors" block you can set up your preferential colors for the different parts of your program. These changes will become the defaults after clicking "Apply" and re-saving your program.

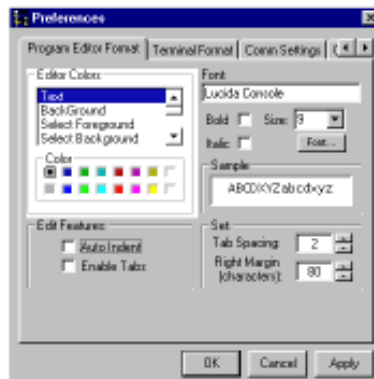

Figure 2.29: Dialog Box for Changing Text Colors in the Program Editor Window

Downloading a Program to the MDrive Motion Control

NOTE: Before downloading any programs type **FD** and press ENTER to set the MDrive to the Factory Defaults.

There are two basic sources from which you can download programs to the MDrive Motion Control:

- 1) Directly from the Program Editor Window of the IMS Terminal.
- 2) From a file folder located on a hard drive or removable disk.

There are also two ways to enable the download dialog box.

- 1) Click the menu item “Transfer > Download”. The Download Dialog Box will open.

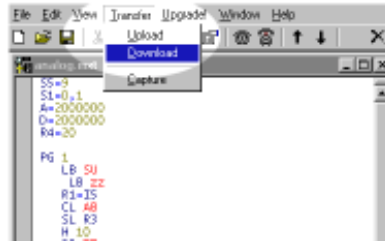

Figure 2.30: Program Download Drop-Down Menu

- 2) Click the Download Button  on the Main Tool Bar. The Download Dialog Box will open.



Figure 2.31: Download Dialog Box

Select the “Source Type > Edit Window” option, and click download. The program will transfer to the MDrive Motion Control.

If a Program has been previously created and stored, it may be downloaded to the MDrive Motion Control from the text file by selecting “Source Type > File” on the dialog box and typing in a drive location:\file name in the “File Name” box on the dialog, or by browsing to the file location. Ensure the programs have been saved with the <mtx> extension for MDrive.

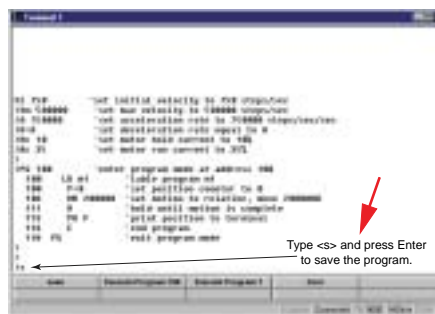





Figure 2.32: Terminal Window Displaying Downloaded Program

- 3) Once the program is downloaded, type **s** and press ENTER to Save the program. (Always Save your Programs!)
- 4) Now type **EX 100** and press ENTER. (EX=Execute and 100 is the Program Number.) Your MDrive should move 200000 steps and then print the position.

NOTE: The program can be stopped by pressing the Escape Button  or by pressing <Ctrl C>  + .



N NOTE: The program is not downloaded to the Terminal Window. It is downloaded directly to the MDrive. What is shown in the Terminal Window is an echo of the downloaded program.

N NOTE: Because the program is downloaded directly to the MDrive, the unit must be powered up and the sign-on message must be displayed (communicating).

N NOTE: When the program is downloaded, the color of all characters will be changed to black and line numbers will be added.

N NOTE: After the program is downloaded it must be saved. Type an <s> next to the cursor and press Enter to save the program.

Uploading a Program From the MDrive Motion Control

NOTE: Be certain the program is stopped by pressing the Escape Button  or by pressing <Ctrl C>  + .

There are two ways to upload programs from the MDrive Motion Control:

- 1) Directly to the Program Editor Window of the IMS Terminal.
- 2) To a file folder located on a hard drive or removable disk.

There are also two ways to enable the upload dialog box.

- 1) Click the menu item “Transfer > Upload”. The Upload Dialog Box will open.
- 2) Click the Upload Button  on the Main Tool Bar. The Upload Dialog Box will open. The Upload Dialog box is similar in appearance to the Download Dialog box.

With the Upload Dialog Box open, select the “Destination Type > Edit Window” option, click “Upload”. The program will transfer from the MDrive Motion Control.

Programs may also be uploaded from the MDrive Motion Control directly to a text file by selecting “Destination Type > File” as the Destination and typing in a drive location:\file name in the “File Name” box on the dialog box.

NOTE: When uploading Program Files from the MDrive they will be slightly changed from the original. The MDrive will upload the Program only with the data within the Program. That is, the data between the two Program Modes (PG). Data such as Variables entered outside the PG Modes will not be uploaded. The uploaded program will also have a header [PROGRAMS] and a footer [END]. These will not affect your program as they are remarked with the apostrophe (‘) or they can be removed during editing.

You may Upload the Program Variables by clicking “Variables” in the Upload Dialog Box. However, this will upload all of the current Variables, not just those associated with the Program.

Setting the Programmable Function Keys

The IMS Terminal has the capability of programming up to 10 Function Keys, a feature typically found in more advanced terminal programs. The Function Keys can be set to provide quick access to commonly used MDrive Immediate mode commands, execute programs, or even hold entire MDrive programs up to 2048 characters.

To access the function key setup dialog box, right-click the function key area (See Figure 2.35) at the bottom of the Terminal Window. The window below will be displayed. To setup the function keys:

- 1) In this example the “Save” command is used. Enter “Save” in the Captions text field, this will be displayed on the function button.

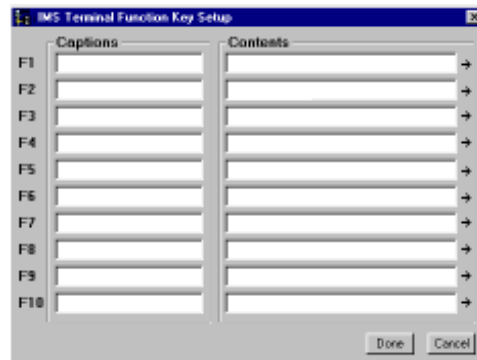

Figure 2.33: Function Key (s) Configuration Page

- 2) Enter the text string in the Contents field consisting of MDrive Motion Control commands and ASCII control codes. For the “save” command the letter “s” is entered.

Each command must be terminated with a Carriage Return (^M) and a pause time. Typically 50 msec (^m) is sufficient.

A fly-out dialog can be brought up by clicking the arrow on the right of the function key “Contents” field. This enables the programmer to embed common ASCII control codes in the function key text string.

- 3) Click “Done” to set the function.

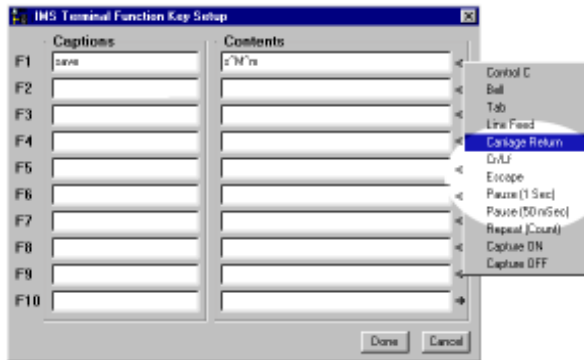



Figure 2.34: Entering Data for the Function Key (s)

To activate the Function, Click the F1 Function Key or press the  key on your keyboard.

Note: Holding the mouse pointer over the function key will display a small identification box which shows the Function Key number and the data it contains. The Function Keys are numbered left-to-right: F1..F5 and F6..F10.

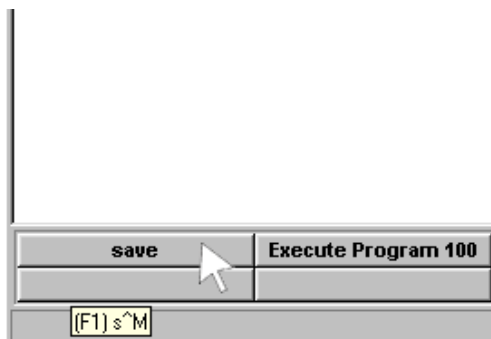

Figure 2.35: Activating a Function Key

Program Troubleshooting

The IMS Terminal offers several tools to help you troubleshoot and analyze programs. They are:

- Execute in Single Step Mode
- Execute in Trace Mode
- The Scroll Back Function
- The Capture Function

Single Step Mode

The Single Step Mode allows the user to execute a program in the Immediate Mode one line at a time. This will help the user to define problem areas by process of elimination. To use Single Step Mode, do the following:

It is recommended that you List (L) the program in the Terminal Window and either print it on paper or cut and paste it to another Program Edit Window. This will allow you to look ahead and see what line is coming up next.

- 1) Have the system and the program ready to run.
- 2) To run in Single Step Mode add a comma and the number two (2) to the execute command.
Example: The Program Label is <aa>. Type EX aa , 2. The program will run one line at a time.
- 3) Each line will be executed and listed in the Terminal Window and the Program will stop.
- 4) To execute and list the next line, press the Space Bar.
- 5) Press the Space Bar for each successive line until the program has completed.

While the program is executing, it will stop after each line is listed. At this time you may enter immediate commands such as velocity variables or actual moves as tests within the program. After entering immediate commands you may continue running in Single Step Mode by pressing the Space Bar again.

If you decide to cancel the Single Step Mode press the "Enter" key and the program will run in normal mode and finish or press Escape (Esc) to abort the program.

Trace Mode

The Trace Mode allows the user to run a program and list each line as it is executed. Running Trace Mode in conjunction with the Scroll Back Function or the Capture Function will enhance your program troubleshooting tasks. To run Trace Mode:

- 1) Have the system and the program ready to run.
- 2) To run in Trace Mode add a comma and the number one (1) to the execute command.
Example: The Program Label is <aa>. Type EX aa , 1. The program will run in Trace Mode and each line will be executed and listed in the Terminal Window.
- 3) Each line can now be analyzed.

On very large programs all of the lines may not be displayed if the "Scroll Back Buffer" value is set too low. The Scroll Back Buffer can be set to a higher value allowing you to Scroll Back farther in the program .

The Scroll Back Buffer

The "Scroll Back Buffer" function for the IMS Terminal Window can be set to different line values. It allows you to scroll back in the program that has already been displayed in the Terminal Window. It can be very useful when troubleshooting a long program.

To set the Scroll Back Buffer:

- 1) Open the Preferences Page for the IMS Terminal Window.
- 2) Click on the "Comm Settings" tab at the top of the page. The following screen will be displayed.
- 3) In the highlighted area in the Figure below you will see a dialog box for "Scroll Back".
- 4) To the left of the current value there is a small arrow to drop down the list. The list covers up to 2000 lines. You can select a value up to 2000 lines from the list.
- 5) If you wish to set the value higher, DO NOT open the drop down list. Simply click on the displayed value to highlight it and type in the new value up to a maximum of 32,000 lines.

NOTE: The Scroll Back Buffer utilizes RAM to store the data. The greater you set the Scroll Back Buffer capacity the greater the amount of RAM used.



Figure 2.36: Setting the Scroll Back Buffer

The Capture Function

The Capture Function allows you to capture Terminal Communications into a text file for the purpose of troubleshooting. You may have a program that fails after running a number of times. It may be from an accumulation of position errors or other factors. By enabling the Capture Function you can store an entire text file of the received communications to your hard drive for analysis.

Enable the Capture Function

The Capture function may be enabled through the drop-down menu under “Transfer”. When you click on “Capture” a dialog box will be displayed.

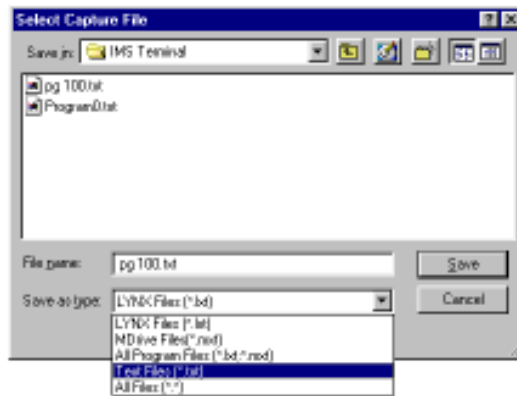

Figure 2.37: The Capture Dialog Box

Give the file you will be capturing a name and be certain to save it as a [.txt] file and click “Save”.

NOTE: The Capture Function may also be enabled through the Fly-Out menu on the Function Key configuration page by inserting it into the command string in the “Contents” line. However, the Capture Function can not be programmed with the Repeat command.

Upon clicking Save, the faded (disabled) Capture title below the Function Keys will change to “Capture ON” and to black letters.

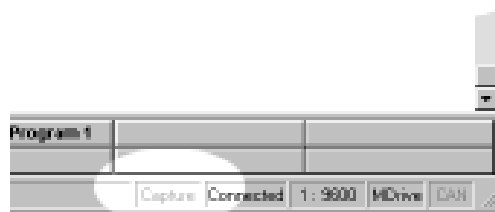

Figure 2.38: Capture Off Indicator



Figure 2.39: Capture ON Indicator

You are now ready to run the program. The program in this example will cycle five (5) times. The data will scroll up the Terminal Window while a copy of the data is captured into the text file simultaneously.

Once the program stops, return to the “Transfer” Drop-Down menu and click on “Stop Capture”. The data that is currently in the Terminal Window is now also saved as the prenamed text file in the IMS Folder.



Figure 2.40: Stop Capture Command in Transfer Drop-Down Menu

Upgrading the MDrive Motion Control Firmware

Before Upgrading

First download the version of firmware you wish to use for the upgrade. (www.imshome.com)

An isolated communications system free of electrical noise and interference is essential for trouble free communication.

During upgrades, the communication baud rate is switched from 9600 to 19,200 and is more susceptible to electrical noise. Your communications cable should be kept to a minimum length of 6 feet.

When using a laptop PC it is recommended that you power the RS-232 to RS-485 cable with an external +5 VDC power supply. This will fortify communications.

The MDrive will remain in the Upgrade Mode until the Upgrade is completed. Cycling power will not clear the Upgrade Mode.

Procedure

- 1) Open "IMS Terminal". The following screen should be displayed. The left panel is the Program Edit Window and the right panel is the Terminal Window. The Firmware Upgrade will superimpose several dialog boxes and instructions over these two windows.



- 2) Check to see that the terminal window is set for MDrive communication.
 - Right click in the Terminal Window.
 - Click "Preferences" near the bottom of the pop-up menu.
 - A "Preferences" dialog box will be displayed.
 - Click on the "Comm Settings" tab at the top of the box. The following page will be displayed.
 - Confirm that MDrive is selected in the "Devices" block.



- 3) Power up the MDrive Motion Controller.
 - The sign on message will appear.
 - "Copyright 2001-2003 by Intelligent Motion Systems, Inc."



- 4) Check and/or reestablish communications if the sign on message does not appear.

- 5) Type UG 2956102 in the Terminal Window and then press <enter>. Include the space between the G and the 2.
 - **NOTE:** The only way to get out of the upgrade mode is to complete the upgrade. Cycling power will not help.
 - The MDrive will return a random symbol character (ô or ö) when it is in the upgrade mode.



- 6) Click the "Upgrade" menu item on the IMS Terminal menu bar.

- 7) Message appears: "During upgrade, the baud rate is changed to 19,200."
 - Click "OK"



- 8) Message: "Welcome to the MDrive Motion Controller upgrader. Press next to continue."
 - You do not need to enter data in the windows. This will fill in automatically as you progress.
 - Click "Next"

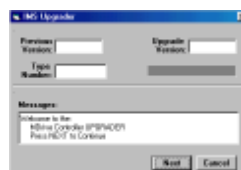

9) The Windows Explorer page “Select MDrive upgrade file” opens.

- Browse and select the desired version of the upgrade file.
- Click “Open” or double click the file.



10) Message appears: Step 2 Select upgrade file.

- The Upgrade Version will now appear in the Upgrade Version window.
- Click “Next”

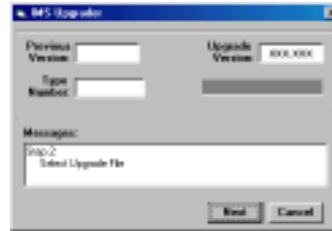

11) Message appears: Step 3 Reminder Press cancel if you need to setup Comm port.

- **The Comm port has been setup previously. This is just a reminder.**
- Click “Next”

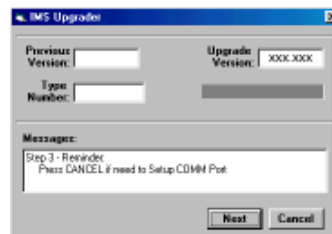

12) Message appears: Step 4 Connect RS-422 cable to the MDrive Controller.

- **The RS-422 has been connected previously. This is just a reminder.**
- Click “Next”

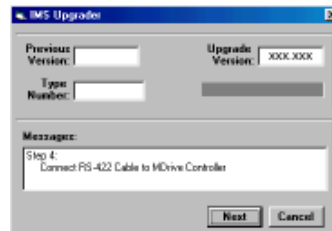

13) Message appears: Step 5 If MDrive Controller is not in the Upgrade mode, press cancel then type 'UG 2956102' in the terminal window.

- The MDrive Controller was placed in the Upgrade mode previously. **DO NOT ENTER CODE AGAIN.**
- Click “Next”

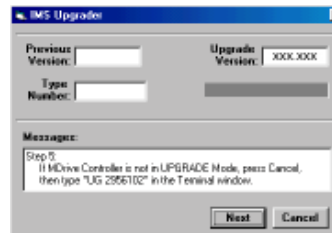

14) Message: Step 6 Power up or cycle power to MDrive Controller.

- The unit has been previously powered up. **Do not cycle power.**
- Click “Next”

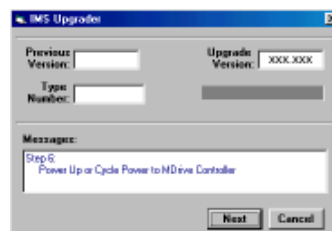

15) Message: Step 7 Establishing Comm with MDrive Controller.

- Wait for step 8 to appear.

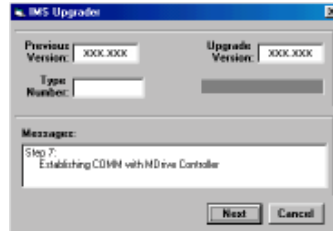

16) Message: Step 8 Press upgrade button to start.

- Click the upgrade button.

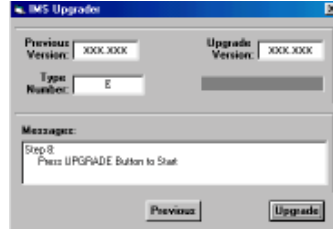

17) Message: Step 9 Press ABORT to abort upgrade.

- DO NOT abort the upgrade. The MDrive will remain in the upgrade mode and the upgrade will have to be completed.
- Monitor the progress in the “Upgrading...%” window.
- Step 10 will appear when DONE

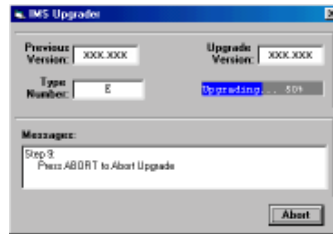

18) Message: Step 10 Resetting MDrive Controller. Then Press DONE.

- Click “DONE”
- Upgrade window will close.

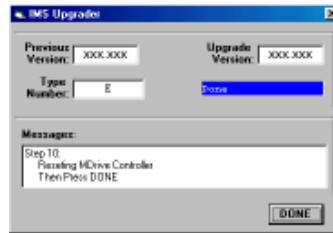

19) Press “Control + C” <Ctrl + C> in the Terminal Window to reset the MDrive Controller and exit the upgrade mode.

- The sign on message will appear. “Copyright 2001-2003 by Intelligent Motion Systems, Inc.”
- The > cursor will appear.



20) The MDrive Motion Controller firmware has been upgraded.

21) Optional confirmation of the upgrade: Type “PR VR” in the terminal window and press <enter>.

- The new firmware version is displayed.



NOTE:

The IMS Terminal automatically shifts to a 19,200 Baud Rate upon clicking the “Upgrade” command.

NOTE:

In the event of loss of power or disconnection of the RS-232 cable, the unit will maintain the “Upgrade” mode on Power Up. The Upgrade must be completed. **DO NOT** retype “UG 2956102”!

Begin with Step 6 of the above procedure and continue the Upgrade.

MDrive Motion Control Programming

The MDrive programming language consists of simple 1-2 character mnemonics.

Operational Modes

There are two operational modes for the MDrive. Immediate and Program:

- 1] Immediate: Commands are issued and executed directly to the MDrive Motion Control by user input into the terminal window.
 - 2] Program: Commands and processes are run from within an MDrive program. This mode is also used for program input.
-

Basic Components of MDrive Motion Control Software

Instructions

An instruction results in an action. There are three types of Instructions:

Motion

Motion instructions are those that result in the movement of a motor. The syntax of these commands are as such: first type the command followed by a space, and then the velocity or position data. For example, *MA 2000* will move the motor to position 2000.

I/O

An I/O instruction results in the change of parameters or the state of an Input or Output. The syntax of these commands are as such: first type the command followed by a space, then the I/O #, then an equal sign, then the data. Example: *PR I1* will read the state of input 1, *O2=0* will set output 2 to 0.

Program

A program instruction allows program manipulation. The syntax of these vary due to the nature of the command. Some command examples would be: *PG 100*, which toggles the system into program mode starting at address 100; *BR LP, I1=1*, which will Branch to a program labeled LP if Input 1 is true.

System

A system instruction is an instruction that can only be used in immediate mode to perform a system operation such as program execution (EX) or listing the contents of program memory (L). For example: *EX 100* will execute a program located at line 100 of program memory space, or *EX K1* will execute a program labeled K1.

Variables

Variables are labeled data that allow the user to define or manipulate data. These can also be used with the built-in math functions to manipulate data. There are two classes of variables: factory defined and user defined. There are 22 user program labels and variables available. The syntax for each variable may differ.

Factory Defined Variables

These variables are predefined at the factory. They cannot be deleted. When an FD (Factory Default) instruction is given, these variables will be reset to their factory default values. There are two types of factory defined variables:

- Read/Writable: These factory defined variables can have their value altered by the user to effect events inside or outside of a program. For example A (Acceleration Variable) can be used to set the Acceleration, or P (Position Variable) can be used to set a position reference point.
- Read Only: These factory defined variables cannot be manipulated by the user, but contain data that can be viewed or used to effect events inside a program. For example V (Velocity Variable) registers the current velocity of the motor in steps per second.

User Defined Variables

The VA instruction allows the user to assign a 2 bit character name to a user defined (32 bit value) variable.

The restrictions for this command are:

- 1) A variable cannot be named after an MDrive Motion Control Instruction, Variable or Flag.
- 2) The first character must be alpha, the second character may be alpha-numeric.
- 3) A variable is limited to two characters.

With these the user can define a variable to store and retrieve data and perform math functions. When the FD (Factory Defaults) instruction is given, these variables will be deleted! There are two types of user defined variables:

- Global Variables: Global variables are variables that are defined outside of a program. The benefit to using a global variable is that no user program memory is required. For example the user can define a variable called SP for speed by entering *VA SP* into the terminal. The user can then set that variable to equal the value of the read only variable V (velocity) by entering *SP = V* into the terminal.
- Local Variables: This type of user defined variable is defined within a program and can only effect events within that program. It is stored in RAM. Examples of this type of variable will be given later in the section. It is worthy of note that a local variable is not static, but is erased and declared again each time a program is executed.

Flags

Flags show the status of an event or condition. A flag will only have one of two possible states: either 1 or 0. Unlike variables, there are only factory defined flags.

Factory Defined Flags

Factory defined flags are predefined at the factory and cannot be deleted. When a FD (Factory Defaults) instruction is given, these flags will be returned to their factory default state. There are two types of factory defined flags:

- **Read/Writable:** This type of flag is user alterable. They are typically used to set a condition or mode of operation for the MDrive Motion Control. For example EE = 1 would enable encoder operation, or EE = 0 would disable the encoder functions.
- **Read Only:** Read Only flags cannot be modified by the user. They only give an indication of an event or condition. Typically this type of flag would be used in a program in conjunction with the BR (Branch Instruction) to generate an if/then event based upon a condition. For example the following line of code in a program BR SP, MV = 0 would cause a program to branch to a subroutine named "SP" when the MV, the read only moving flag, is false.

Keywords

Keywords are used in conjunction with the PR and IP instructions to indicate or control variables and flags. For instance, PR UV would print the state of all the user-defined variables to the screen. IP would restore all the factory variables from the EEPROM.

Most Commonly Used Variables and Commands

Variables

MS

MS (Microsteps Select) defines the resolution of the stepping motor.

- An MDrive rotates 1.8° per step or 200 steps per revolution.
- The MS selection divides the number of MDrive steps to yield a finer resolution.
- An MS value of 256 x 200 would yield 51200 microsteps per revolution. (Each Motor step will be divided into 256 Microsteps.)
- The MS default is 256.
- *To read the MS value, type PR MS and press enter*
- *To write the MS value, type MS=<number> and press enter*
- As we continue you will see that all motion variables use this value.

P

P indicates the Position in either steps or encoder counts depending upon the enable/disable state of encoder functions.

- P takes its reading from C1 (Counter 1) when encoder functions are disabled. The reading is taken from C2 (Counter 2) when encoder functions are enabled.
- *To read the position, type PR P or PR C1/C2 then press enter*
- *To zero the position, type P=0 then press enter*

VI

Initial Velocity in steps per second. (Step size is a function of the value of MS).

- *To read the initial velocity, type PR VI then press enter*
- *To write to the Initial velocity, type VI=<number> then press enter*
- The VI default is 1000

VM

Maximum or final Velocity in steps per second. (Step size is a function of the value of MS).

- *To read the final velocity, type PR VM then press enter*
- *To write to the final velocity, type VM=<number> then press enter*
- *The default VM Value is 768000*

A

Acceleration in steps per second². (Steps per second, per second.)

- The velocity of the motor will increase by the value of the Acceleration Rate every second until it reaches the programmed velocity in SL mode or it reaches VM.
- *To read the acceleration, type PR A then press enter*
- *To write to the acceleration, type A=<number> then press enter*
- *The Acceleration Default value is 1000000*

D

Deceleration in steps per second². (Steps per second, per second.)

- The velocity of the motor will decrease by the value of the Deceleration Rate every second until it reaches the programmed velocity in SL mode or it reaches VI.
- *To read the deceleration, type PR D then press enter*
- *To write to the deceleration, type D=<number> then press enter*
- *The Deceleration Default value is 1000000*

Math Functions

Another powerful feature of the MDrive Motion Control is its ability to perform common math functions and to use these to manipulate data.

Addition K2[†]=P+R2
 Subtraction K3[†]=R1-P
 Multiplication A=A*2
 Division A=A/2

[†]User-defined variable used as an example.

Motion Commands

Motion Commands are those that cause the MDrive to move or affect the movement of the MDrive. There are a few factors that must be considered when programming motion commands. Linear distances, number of revolutions, degrees of rotation and timed moves can be calculated and programmed from these factors.

MA

Move to an Absolute position relative to a defined zero position.

For example, type the following commands followed by pressing enter:

```
P=0           'set the current position to 0 (zero)
MA 20000      'move 20000 steps from 0 in the plus direction
PR P         'the terminal screen will read 20000
MA 3000       'move to 3000 steps from 0 in the plus direction
PR P         'the terminal screen will read 3000
```

Absolute moves are always relative to 0 (zero).

You may program moves in the minus direction by typing the minus sign (-) before the value.

MR

Move the number of steps programmed relative to current position.

For example, type the following commands followed by pressing enter:

```
P=0           'set the current position to 0 (zero)
MR 20000      'move 20000 steps from the current position in the plus direction
PR P         'the terminal screen will read 20000
MR 3000       'move 3000 steps from the current position in the plus direction
PR P         'notice the position read is 23000 and not 3000
```

Relative moves are cumulative and are either added to or subtracted from the current position.

You may program moves in the minus direction by typing the minus sign (-) before the value.

SL

Move at a constant velocity.

```
SL 200000 'the motor moves at a constant velocity 200000 steps per second
```

The Slew Command overrides the VM (Maximum Velocity) parameter.

The value of the Slew Command may be changed “on the fly”.

You may program moves in the minus direction by typing the minus sign (-) before the value.

H

An H (Hold Command) should typically follow any MA or MR commands in a program so that program execution is suspended until the motion is complete.

Below is a usage example.

```
PG 100      'enter program mode at address 100
LB M1       'label program M1
MR 20000    'set mode to relative, move relative 20000 steps
H           'hold until motion completes
MR -20000   'move relative -20000 steps
H           'hold until motion completes
E           'end program
PG          'exit program mode
```

A delay time value (1 to 65000 milliseconds) may be programmed with the Hold Command.

(Note: There are circumstances where you may not want to hold up program execution.)

All motion is programmed either Microsteps Per Second or (when the Encoder is enabled) Encoder Counts (Pulses) Per Second.

All Motion is directly affected by the Motion Command and the Program Variables.

Factors

Motor Steps:

All IMS MDrives are 200 step motors. They rotate at 1.8° per pulse. 200 steps would equal 1 revolution.

Microsteps: (MS)

Microsteps divide the 200 Motor Steps into smaller steps to improve smoothness and resolution of the MDrive. Using the default setting of 256 for MS, the 200 motor steps are increased to 51200 Microsteps. One motor revolution requires 51200 Microsteps with the MS set at 256. If you were to set the MS to 128, one revolution of the MDrive would now require 25600 Microsteps.

Move Command:

The Move Absolute (MA) and the Move Relative (MR) Commands are programmed in Microsteps Per Second or if the Encoder is enabled, Encoder Pulses Per Second. If the MS was set at 256 and you were to program a move of 51200 Microsteps per second, the MDrive would turn one full revolution in 1 second (1 RPS). This also equates to Revolutions Per Minute (60 RPM). If the MS was set to 128, one full revolution of the motor would be 25600 Microsteps (128 x 200). If you programmed a move of 51200 Microsteps per second, the MDrive would turn 2 full revolutions in 1 second or 120 revolutions per minute.

If the Encoder is enabled the Move Commands use different values. The Encoder has 512 lines and yields 2048 pulses or counts per revolution. Therefore, the MR and MA Command values are programmed in Encoder counts. One full revolution would be programmed as MR or MA 2048.

When the Encoder is enabled, the MS value is defaulted to 256. It cannot be changed.

Knowing these factors you can program a multitude of different movements, speeds, and time intervals.

Linear Movement:

You have a rack and pinion or a ball screw to move a linear axis. The rack and pinion or ball screw moves the linear axis 0.1 inches for each revolution. You need to move 7.5 inches.

7.5 inches divided by 0.1 inches = 75 MDrive revolutions.

Assuming an MS of 256 (51200 Microsteps) is programmed, 51200 Microsteps x 75 revolutions requires a move of 3840000 microsteps.

Knowing the values of the Variables as well as the required move, you can calculate the actual time it takes to move the axis the required distance. This is done with a Trapezoidal Profile as shown below.

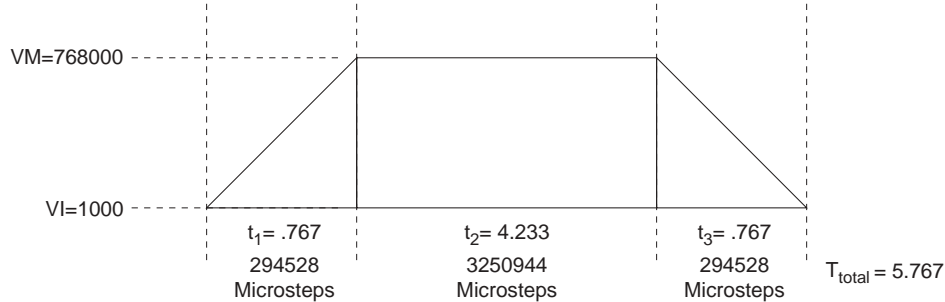

Figure 2.41: Trapezoidal Move Profile

Calculating Axis Speed (Velocity)

There are several steps required to determine the actual axis speed. They are all based on the Trapezoidal Profile above.

Known Values and Parameters:

- VM 768000 Steps/Sec.
- VI 1000 Steps/Sec.
- A 1000000 Steps/Sec².
- D 1000000 Steps/Sec².
- MA/MR 3840000 Microsteps

Determine the Acceleration (A) and Deceleration (D) times (t₁ and t₃). Since the Deceleration (D) value is also 1000000 Steps/Sec. the Deceleration time (t₃) will be the same as the Acceleration time (t₁).

$$(t_1 \text{ and } t_3) = \frac{VM-VI}{A} \text{ or } \frac{768000 - 1000}{1000000} = 0.767 \text{ Seconds}$$

Determine the distance (Steps) traveled in t₁ or t₃.

$$\text{Distance} = \frac{1}{2} (t_1 \times VM) \text{ or } \frac{0.767 \times 768000}{2} = 294528 \text{ Steps.}$$

Determine the t₂ time.

The t₂ time is calculated by dividing the remainder of MA/MR by VM.

The remainder of MA/MR = MA/MR - (t₁ steps + t₃ steps) or 3840000 - 589056 = 3250944.

$$t_2 = \frac{3250944}{768000} = 4.233 \text{ Seconds}$$

Determine the total time. (t₁ + t₂ + t₃) or (0.767 + 4.233 + 0.767) = 5.767 Seconds

The linear axis took 5.767 seconds to move 7.5 inches or an average speed of 78 inches/minute.

Note that the average speed includes the Acceleration and Deceleration. The maximum axis speed attained is approximately 90 inches/minute.

$$\frac{768000}{51200} \times 0.1 \times 60 = 90 \text{ IPM}$$

Rotary Movement:

Again, assume the MS is set to 256. You are using the MDrive to drive a shaft with a timing belt and pulley arrangement. The MDrive pulley is 1" in diameter and the shaft pulley is 2.5" in diameter. You must turn the shaft 270°. First of all, the shaft will rotate 1 full revolution for every 2.5 revolutions of the MDrive. 270° is 0.75 of a revolution. $0.75 \times 2.5 = 1.875$ MDrive revolutions to turn the shaft 270°. If 51200 Microsteps is 1 MDrive revolution then the MDrive must be programmed to move 96000 Microsteps (51200×1.875).

You may also do many of the calculations in reverse to calculate MDrive moves to meet a required move of your device. A linear or rotational move as well as speed may be translated into an MDrive command.

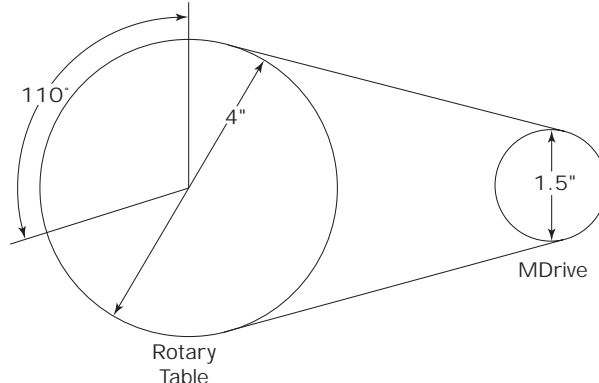

Figure 2.42: Rotary Drive Example

In the example above, the belt driven Rotary Table must be turned 110° at 3 RPM. How should the MDrive be set up? Bear in mind that all the numbers are approximate due to rounding.

Mechanical ratio between the MDrive and the rotary table is 2.666:1. That is, the MDrive must rotate 2.666 revolutions for the table to rotate 1 revolution and the table will rotate 2.666 times slower than the MDrive.

In order to move the table 110° the MDrive must move 293.3°.

$$110 \times 2.666 = 293.3^\circ$$

If 51200 steps = 1 revolution then 1° = 142.222 steps.

$$\frac{51200}{360} = 142.222 \text{ steps}$$

The MDrive must be programmed to move 41713 steps to rotate 293.3°

$$142.222 \text{ steps} \times 293.3^\circ = 41713 \text{ steps}$$

In order to rotate the table at 3 RPM the MDrive must turn at 8 RPM.

$$3 \text{ RPM} \times 2.666 = 8 \text{ RPM}$$

If you were to set VM at 51200 and MS set at 256 the MDrive will rotate 1 full revolution (51200 steps) in 1 second or 1 RPS. In order to rotate at 8 RPM, the MDrive must rotate at 0.13333 RPS.

$$\frac{8}{60} = 0.133333 \text{ RPS}$$

In order to rotate at 0.13333 RPS the VM must be set at 6827 steps/sec.

$$51200 \times 0.133333 = \text{VM } 6827$$

Programming with the Optional Encoder Enabled

An optional 512 line encoder is available. When the Encoder is enabled (EE=1) the programming also changes. All motion must now be programmed by the encoder pulses. The Encoder operates in the “Quadrature” format. That is, there are four Encoder pulses for each Encoder line or 2048 pulses per revolution ($512 \times 4 = 2048$). (See Figure below.) If you were to program motion using the MR (Move Relative) or the MA (Move Absolute) commands the motor would rotate a distance equal to the pulses.

Example:

A programmed move of 7168 pulses would result in the motor rotating 3.5 revolutions at a velocity controlled by VM.
($7168 \div 2048 = 3.5$ revolutions)

If you were to program motion using the SL (Slew) command the motor would rotate at a “pulses per second” rate based on the programmed value.

Example:

An SL (Slew) rate of 7168 pulses was programmed. The motor will rotate at 7168 pulses/sec., 3.5 RPS, or 210 RPM.
($7168 \div 2048 = 3.5$ RPS $\times 60 = 210$ RPM)

When the Encoder is enabled, the parameters are also changed to be compatible with the 2048 pulses.

The Encoder Enabled defaults are:

VM	30720 Pulses/Sec.
VI	40 Pulses/Sec.
A	40000 Pulses/Sec
D	40000 Pulses/Sec.

To enable the Encoder the program syntax is <EE=n> where n is a zero (0) or a one (1). The default is zero (0) which is Encoder disabled. To enable the Encoder, program EE=1.

Any motion will now be programmed in Encoder pulses. You can calculate the distance or velocity you need in a similar manner as done previously only with different factors.

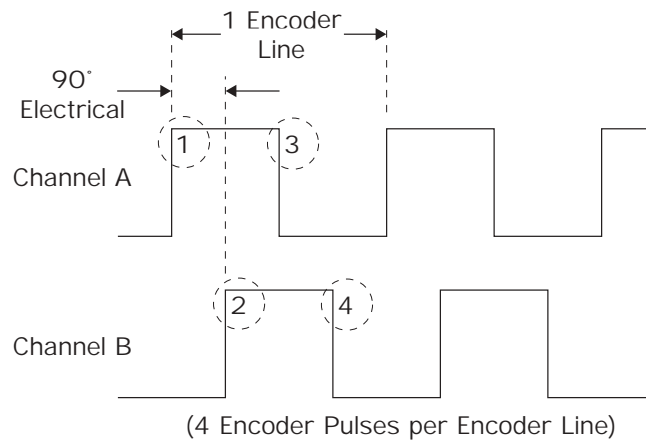

Figure 2.43: Quadrature Encoder Pulses

Several Variables work in conjunction with Encoder Enable (EE). They are:

DB	Encoder Deadband
SF	The Stall Factor Variable
SM	The Stall Detection Mode
ST	Stall Flag
PM	Position Maintenance

EE - Encoder Enabled

When the Encoder is enabled, all motion is “closed loop”. That is, motion counts are delivered from the MDrive Electronics to the motor which turns the encoder. The encoder sends counts back to the drive to complete the motion. If you programmed the MDrive to move 2048 counts, the driver would attempt to output 2048 counts provided the Stall Factor (SF) value or other fault is not encountered. If no faults were encountered, the driver would output the full 2048 counts. Depending on which variables were set, the driver would then wait until the position (plus or minus the Encoder Deadband) was read and confirmed.

DB - Encoder Deadband

The Encoder Deadband is a Variable that is set in Encoder Counts. Motion will be deemed complete when the Encoder Counts are within the Deadband variable. With DB=5 the motion of 2048 counts would be complete between 2043 and 2053 counts.

SF - Stall Factor

The Stall Factor is a Variable which is entered in Encoder Counts. The Stall Factor might be compared to the “following error” or “lag error” of a servo drive. The Stall Factor is triggered by the number of counts output from the MDrive Electronics to the motor as compared to the number of counts returned by the encoder. The comparison should always be within the value of the Stall Factor, otherwise a fault will occur and the Stall Flag (ST) will be set. If Stall Detection Mode (SM=0) is active, the motion will be stopped.

Example:

A Stall Factor of 30 counts (SF=30) is programmed. A motion command of 2048 counts is programmed. The MDrive reaches a mechanical bind at 2000 counts. The driver will keep outputting motion counts until 2030 counts (present position plus the SF value) and then the Stall Flag (ST) will be set. The MDrive will be stopped if the Stall Detection Mode (SM=0) is active.

SM - Stall Detection Mode

The Stall Detection Mode can be programmed to stop the MDrive (SM=0) or to allow the MDrive to continue (SM=1) when the Stall Factor (SF) is reached. Whether SM is active or not, the Stall Flag will always be set when the SF is encountered.

ST - Stall Flag

The Stall Flag will be set any time the SF is reached regardless of the state of the Stall Detection Mode (SM). If the Stall Flag is set, the user must reset it to zero (0).

PM - Position Maintenance

Position Maintenance (PM) is active only after the motion has completed. Position Maintenance is used to maintain position when there might be an external force on the drive. If Position Maintenance is enabled (PM=1) and the Stall Detection Mode is enabled (SM=0), the MDrive will be driven back to its final position if it was forced out of position provided the Stall Factor (SF) was not reached.

If Position Maintenance is enabled (PM=1) and the Stall Detection Mode is disabled (SM=1), the MDrive will be driven back to its final position if it was forced out of position regardless of whether the Stall Factor (SF) was reached or not.

There are three other variables, although not directly connected to EE, that do affect the overall operation when in Encoder Mode. They are:

HC	- Motor Hold Current
HT	- Motor Hold Current Delay Time
MT	- Motor Settling Delay Time

HC - Hold Current

When motion is complete, the MDrive Electronics will switch from Motor Run Current (RC) to Motor Hold Current (HC). The Hold Current is set at a lower percentage than the Run Current (RC). However, the Hold Current must be sufficient to overcome an outside force such as an MDrive driving a vertical slide which maintains a load on the MDrive at all times. Actual Hold Current values will vary depending on the application and the load on the MDrive when it is at rest.

HT - Motor Hold Current Delay Time

The Motor Hold Current Delay Time (HT) is a variable that delays the change from Run Current (RC) to Hold Current (HC) at the end of a move. The end of the move is triggered by the MDrive Electronics when it has completed outputting the correct number of counts. Depending on the application, including velocity, deceleration, load and inertia, the MDrive may lag behind a few counts. The HT will allow the MDrive to finish its move before applying the lower HC.

MT - Motor Settling Delay Time

A stepping motor may ring or oscillate in minuscule amounts at the completion of a move until it satisfies the target position. The amount of this “ringing” is dependent on the application including velocity, deceleration, inertia, friction and load. The Motor Settling Delay Time (MT) allows the motor to stop “ringing” before checking the position count. If the MDrive Electronics tried to check the position count during this ringing, it would assume a position error and try to correct an already moving MDrive and possibly cause ringing of a larger magnitude and longevity. Typically, the MT is set between 50 and 100 milliseconds. It is recommended that there is always a Motor Settling Time programmed any time you are in EE=1 mode.

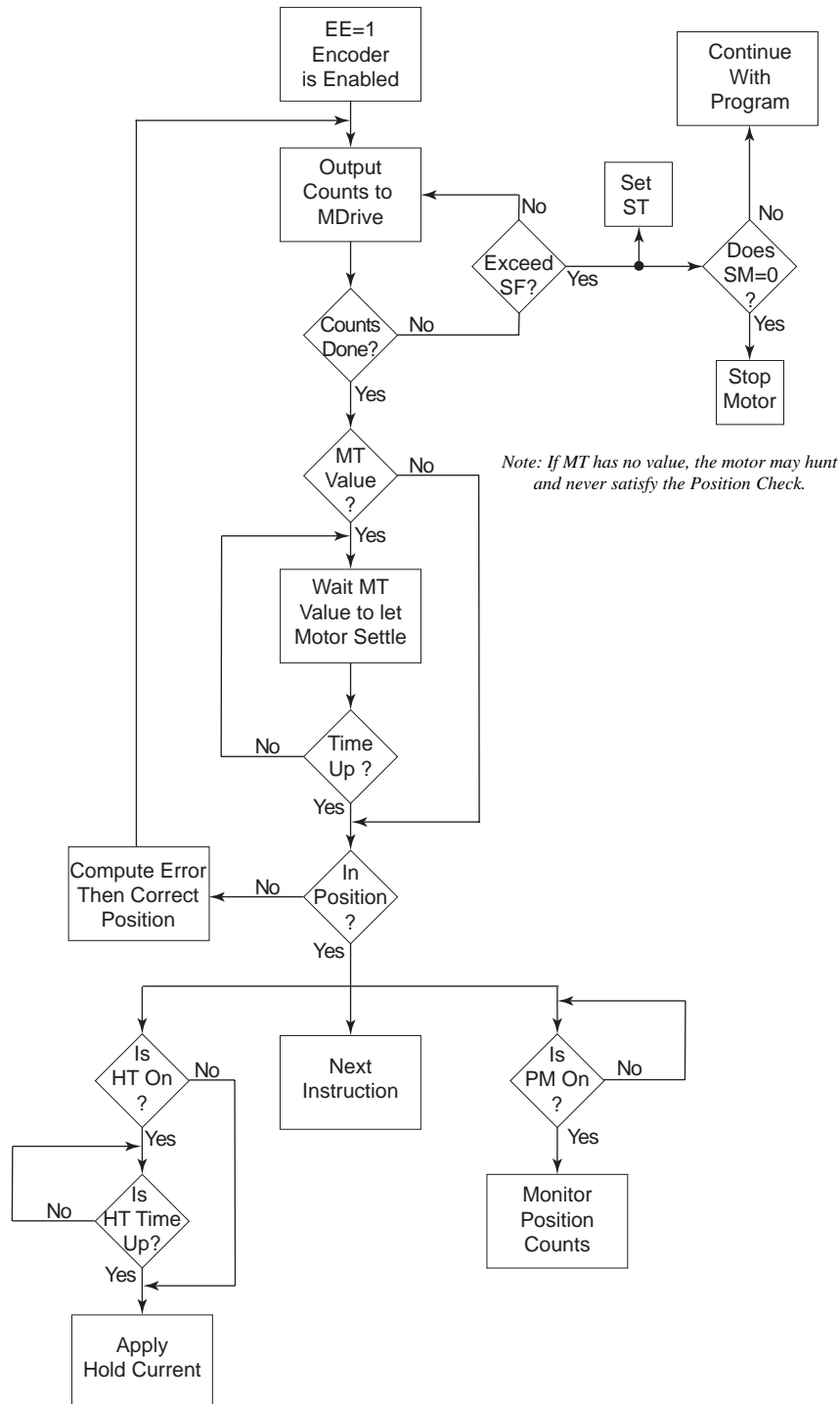

Figure 2.44: EE=1 Flowchart

I/O Commands

S < 1 - 4 >

This command configures the Type and Active state of I/O points 1-4.

Using the PR command to read IO parameters

Read IO1 Setup – “PR S1”

Read IO2 Setup – “PR S2”

Setting the I/O parameters

Set IO 3 parameters – “S3=0,1” Sets IO3 as a General Purpose Input, Active High

For example: To set IO4 as a Jog+ Input/Active Low

S4 =7,0

I < 1 - 4 >

Used to read the state of an individual input.

PR I1 will read the state of input 1 and display it to the terminal window.

BR K5, I2=0 will branch to the program address labeled K5 when Input 2 is LOW

IN

Used to read the decimal equivalent of the 4 bit binary number represented by all 4 inputs collectively. Note the Input 4 is the Most Significant Bit.

PR IN will print the decimal value of the inputs.

O < 1 - 4 >

Used to set the state of an output.

O2=1 will set Output 2 TRUE

OT

Used to set the 4 bit binary equivalent of the decimal number represented by all 4 outputs collectively. Note the Output 4 is the Most Significant Bit.

OT=13 will set the outputs to 1101

System Instructions

The following System Instructions will be used frequently.

CP

The CP Instruction is used to clear Program memory space.

FD

The FD Instruction is used to return the MDrive Motion Control to its factory default state.

<esc>

The ESCAPE key will stop the user program and stop the motor with no decel rate.

<control C>

CONTROL C will reboot the unit. This includes reloading of the programs stored in nonvolatile memory into RAM and executing any programs residing at label SU (Start Up).

Program Instructions

PG

This instruction toggles the MDrive Motion Control into or out of program mode.

Switch to program mode at address 200

PG 200

xxxxx

Program starting at address 200

xxxxx

xxxxx

Switch out of program mode

PG

LB

The MDrive Motion Control also offers the user the convenience of naming programs, subroutines and processes to ease in branching from one part of a program to another, or calling a subroutine.

These labels, once set, will act as pointers to locations in program memory space.

The LB, or Label Instruction, allows the user to assign a 2 character name to a program or branch process within a program or subroutine.

The restrictions for this command are:

- 1] A label cannot be named after a MDrive Motion Control Instruction, Variable or Flag.
- 2] The first character must be alpha, the second character may be alpha-numeric.
- 3] A label is limited to 2 characters.
- 4] A program labeled SU will run on power-up

Please Note: Any program labeled “SU” will execute on power-up.

Switch to program mode at address 200	PG 200
Label command will name the program	LB K1
	xxxxx
Program named by LB command	xxxxx
	xxxxx
Switch out of program mode	PG

BR

Used to branch conditionally or unconditionally to a routine.

Switch to program mode at address 200	PG 200
Label command will name the program	LB K1
	xxxxx
Program named by LB command	xxxxx
	xxxxx
Unconditional branch to Program Label K1	BR K1
Switch out of program mode	PG

E

Designates the end of a program.

Switches to program mode at address 200	PG 200
Label command will name the program	LB K1
	xxxxx
Program named by LB command	xxxxx
	xxxxx
Unconditional branch to Program Label K1	BR K1
Designates the end of the program	E
Switches out of program mode	PG

H

Delays program execution in milliseconds.

Switches to program mode at address 200	PG 200
Label command will name the program	LB K1
	xxxxx
Program named by LB command	xxxxx
	xxxxx
Delay 2 seconds between re-execution of program	H 2000
Unconditional branch to K1	BR K1
Designates the end of the program	E
Switches out of program mode	P

PRINT

Outputs specified text and parameter values to a terminal or terminal software on a Host PC.

Switches to program mode at address 200	PG 200
Label command will name the program	LB K1
	xxxxx
Program named by LB command	xxxxx
	xxxxx
Prints text in quotes and then POS	PR "Position = " P
Delay 2 seconds between re-execution of program	H 2000
Unconditional branch to K1	BR K1
Designates the end of the program	E
Switches out of program mode	PG

VAR

Command used to define a variable with 8 alphanumeric characters.

Switches to program mode at address 200	PG 200
Define a variable named CT for Count	VR CT
Label command will name the program	LB K1
Increment CT	IC CT
	xxxxx
Program named by LB command	xxxxx
	xxxxx
Prints text in quotes and then POS	PR
Delay 2 seconds between re-execution of program	H 2000
Branch to K1 while CT <10	BR K1, CT <10
Designates the end of the program	E
Switches out of program mode	PG

Section 2.3

MDrive Motion Control Command Set Summary

Setup Instructions, Variables and Flags

Mnemonic	Function	Unit	Range	Syntax Example
BD	Communications BAUD Rate	BAUD	48, 96, 19, 38, 11	BD=<baud>
CK	Check Sum Enable	-	-	CK=<1/0>
DE	Enable/Disable Drive	-	1/0	DE=<1/0>
DN	Device Name	Character	a-z, A-Z, 0-9	DN=<char>
EM	Echo Mode 0 (def)=Full Duplex, 1=Half Duplex	Mode	<0..3>	EM=<mode>
IP	Initial Parameters from EEPROM	-	-	IP
PY	Enable/Disable Party Mode	Mode	1/0	PY=<mode>
UG	Upgrade Firmware	Code	2956102	IMS Term. Upgrader

Miscellaneous Instructions, Variables and Flags

Mnemonic	Function	Unit	Range	Syntax Example
AL	All Parameters, Used with PR (Print)	-	-	PR AL
BY	BSY Flag 1=Prog. Running	-	0/1	PR BY
FD	Return to Factory Defaults	-	-	FD
PR	Print Selected Data and/or Text	-	-	PR <data/text string>
R1	User Register 1	Number	Signed 32 bit	R1=<number>
R2	User Register 2	Number	Signed 32 bit	R2=<number>
R3	User Register 3	Number	Signed 32 bit	R3=<number>
R4	User Register 4	Number	Signed 32 bit	R4=<number>
VR	Firmware Version	Number	-	PR VR
UV	Read User Variables	-	=	PR UV

Motion Instructions, Variables and Flags

Mnemonic	Function	Unit	Range	Syntax Example
(-)	Do Previously Set Mode to/at This Value	per mode		-<number>
A	Set Acceleration	Steps/Sec ²	1000000000	A=<accel>
D	Set Deceleration	Steps/Sec ²	1000000000	D=<decel>
HC	Set Hold Current	% (Percent)	0 to 100	HC=<percent>
HT	Set Hold Current Delay Time	milliseconds	0-65000	HT=<msec>
LM	Limit Stop Mode	-	1-6	LM=<number>
MA	Set Mode and Move to Abs. Position	±Position	Signed 32 bit	MA <±pos>
MD	Motion Mode Setting	-	-	-
MR	Set Mode and Move to Relative Position	±Distance	Signed 32 bit	MR <±dist>
MS	Set Microstep Resolution	Microsteps/step	MSEL Table	MS=<param>
MT	Motor Settling Delay Time	milliseconds	0-65000	MT=<msec>
MV	Moving Flag	-	-	PR MV
RC	Set Run Current	% (Percent)	1 to 100	RC=<percent>
SL	Set Mode and Slew Axis	Steps/sec	±5000000	SL <velocity>
V	Read Current Velocity	Steps/sec	±5000000	PR V
VI	Set Initial Velocity	Steps/sec	1-5000000	VI=<velocity>
VM	Set Maximum Velocity	Steps/sec	1-5000000	VM=<velocity>

I/O Instructions, Variables and Flags

Mnemonic	Function	Unit	Range	Syntax Example
D1	Set Input 1 Digital Filtering	Milliseconds	0-255	D1=<time>
D2	Set Input 2 Digital Filtering	Milliseconds	0-255	D2=<time>
D3	Set Input 3 Digital Filtering	Milliseconds	0-255	D3=<time>
D4	Set Input 4 Digital Filtering	Milliseconds	0-255	D4=<time>
D5	Set Input 5 Digital Filtering	Milliseconds	0-255	D5=<time>
I1	Read Input 1	-	0/1	PR I1, BR I1,<cond>
I2	Read Input 2	-	0/1	PR I2, BR I2,<cond>
I3	Read Input 3	-	0/1	PR I3, BR I3,<cond>
I4	Read Input 4	-	0/1	PR I4, BR I4,<cond>
I5	Read Input 5 (Analog)	-	0-1024	PR I5, BR I5,<cond>
I6	Read Encoder Index Mark Low true			
IN	Read Inputs 1-4 as One Value	data	0-15	PR IN
O1	Set Output 1 to Logic State	-	0/1	O1=<1/0>
O2	Set Output 2 to Logic State	-	0/1	O2=<1/0>
O3	Set Output 3 to Logic State	-	0/1	O3=<1/0>
O4	Set Output 4 to Logic State	-	0/1	O4=<1/0>
OT	Write Data to Outputs 1-4 as One Value	data	0-15	OT=<data>
S1	Setup IO Point 1	Type, Active	Type Table, 0/1	S1=<type>,<active>
S2	Setup IO Point 2	Type, Active	Type Table, 0/1	S2=<type>,<active>
S3	Setup IO Point 3	Type, Active	Type Table, 0/1	S3=<type>,<active>
S4	Setup IO Point 4	Type, Active	Type Table, 0/1	S4=<type>,<active>
TI	Trip on Input	-	-	TI <input>,<addr>
TE	Trip Enable	See Table	<1-4>	TE=<num>

Program Instructions, Variables and Flags

Mnemonic	Function	Unit	Range	Syntax Example
BR	Branch (Conditional/Unconditional)	-	-	BR <addr>, <cond>
CL	Call Subroutine (Conditional/Unconditional)	-	-	CL <addr>, <cond>
CP	Clear Program	Address	1-767	CP <addr>
DC	Decrement Variable	-	-	DC <var/ureg>
E	End Program Execution	-	-	E
EX	Execute Program at Address Using Selected Trace Mode		1-767	EX <addr>, <mode>
H	Hold Prog. Execution Blank/0=Motion stops	milliseconds	Blank(0)/1-65000	H=<msec>
IC	Increment Variable	-	-	IC <var>
L	List Program	Address	1-767	L <addr>
LB	Create a Program Address Label Name			
OE	On Error Handler 0=Disabled	Address	0/1-767	OE <addr>
PG	Start Program Entry at Specified Address	-	Blank/1-767	PG <addr>
RT	Return from Subroutine	-	-	RT
S	Save to EEPROM	-	-	S
VA	Create A User Variable Name			
UV	Read User Variables	-	-	PR UV

Position Related Instructions, Variables and Flags

Mnemonic	Function	Unit	Range	Syntax Example
C1	Set Counter 1	Motor Counts	Signed 32 bit	C1=<counts>
HM	Home to Home Switch	Type	1-4	HM <type>
P	Set/Read Position	Motor/Encoder Counts	Signed 32 bit	P=<counts>
PC	Read Captured Position at Trip	Motor/Encoder Counts	Signed 32 bit	PR PC
TP	Trip on Position	Position	-	TP <pos>, <addr>
TE	Trip Enable	See Table	<0-3>	TE=<num>

Encoder Related Instructions, Variables and Flags

Mnemonic	Function	Unit	Range	Syntax Example
C2	Set Counter 2	Encoder Counts	Signed 32 bit	C2=<counts>
DB	Set Encoder Deadband	Encoder Counts	0-65000	DB=<counts>
EE	Enable/Disable Encoder Functions	-	1/0	EE=<1/0>
HI	Home to Encoder Index	Type	1-4	HI=<type>
I6	Read Encoder Index Mark	-	-	I6
SF	Set Stall Factor	Encoder Counts	0-65000	SF=<counts>
SM	Set Stall Mode	0=Stop Motor/1=Don't Stop	1/0	SM=<mode>
ST	Stall Flag	-	0/1	PR ST

Mathematical Functions

Symbol	Function
+	Add Two Variables and/or Flags
-	Subtract Two Variables and/or Flags
*	Multiply Two Variables and/or Flags
/	Divide Two Variables and/or Flags
<>	Not Equal
=	Equal
<	Less Than
<=	Less Than and/or Equal
>	Greater Than
>=	Greater Than and/or Equal
&	AND (Bitwise)
	OR (Bitwise)
^	XOR (Bitwise)
!	NOT (Bitwise)

Section 2.4

MDrive Motion Control Command Set

USAGE ABBREVIATIONS DEFINED
Program - For use within a user program
ImmEDIATE - Not for use within user program
Read - Use in print statement
Write - Write to a variable

MNEMONIC	FUNCTION	TYPE	USAGE
A	Acceleration	Motion Variable	P/I R/W

DESCRIPTION

The A Variable sets the peak acceleration that will be reached by the MDrive in steps per second². That is, steps per second, per second. If the A was set at 76800 microsteps per second² the motor would accelerate at a rate of 76800 microsteps per second, every second. If the maximum velocity was set at 768000 microsteps per second it would take 10 seconds to reach maximum speed.

USE	UNITS	RANGE	DEFAULT
A=<accl>	Steps/sec ²	0 to 1525878997	1000000

EXAMPLE:

A=20000 'set acceleration to 20000 steps/sec²
A=D 'set acceleration equal to deceleration

RELATED COMMANDS: D

MNEMONIC	FUNCTION	TYPE	USAGE
AL	Retrieve All Parameters	Variable	I R

DESCRIPTION

The AL variable is used with the PR (PRINT) instruction to print the value/state of all variables and flags to the terminal program.

USE	UNITS	RANGE	DEFAULT
PR AL			

RELATED COMMANDS: PR

MNEMONIC	FUNCTION	TYPE	USAGE
BD	BAUD Rate	Setup Variable	P/I R/W

DESCRIPTION

This variable sets the baud rate for serial communications with the MDrive. It sets the rate for the RS-485 interface. The baud rate is set by indicating the first two digits of the desired rate as shown in the range section below.

In order for the new BAUD rate to take effect, the user must issue the S (SAVE) instruction and then reset the MDrive. When the MDrive is reset, it will communicate at the new BAUD rate.

48 = 4800 bps, 96 = 9600 bps, 19 = 19200 bps, 38 = 38000 bps, 11 = 115200 bps

NOTE: If you change the Baud Rate in the MDrive it must be matched in IMS Terminal.

USE	UNITS	RANGE	DEFAULT
BD=<baud>	bits per second	48, 96, 19, 38, 11	9600 bps

EXAMPLE:

BD=96 'set communications BAUD rate to 9600 bps

RELATED COMMANDS: CK

MNEMONIC	FUNCTION	TYPE	USAGE
BR	Branch	Program Instruction	P

DESCRIPTION

The branch instruction can be used to perform a conditional or unconditional branch to a routine in an MDrive program. It can also be used to perform loops and IF THEN logic within a program.

There are two parameters to a branch instruction. These are used to perform two types of branches:

Conditional Branch

This type of branch first specifies an address or process label where program execution should continue if the second parameter, the condition, is true. The condition parameter may include flags as well as logical functions that are to be evaluated.

Unconditional Branch

In this type of branch the second parameter is not specified, then the execution will continue at the address specified by the first parameter.

USE

BR <addr/label, cond>

EXAMPLE:

BR 256, I2 'Branch to program line 256 if Input 2 is TRUE
 BR 120 'Unconditional Branch to program line 120
 BR JC, I1=1 'Branch to process labeled JC if input 1 is True

RELATED COMMANDS: —

MNEMONIC	FUNCTION	TYPE	USAGE
BY	Busy Flag (Read Only)	Busy Flag	P/I R

DESCRIPTION

This read only status flag will indicate whether or not a Program is executing.

USE	UNITS	RANGE	DEFAULT
PR BY	—	0/1	0

EXAMPLE:

PR BY 'read the state of the busy flag

RELATED COMMANDS: PR

MNEMONIC	FUNCTION	TYPE	USAGE
C1	Counter 1 (Motor Counts)	Motion Variable	P/I R/W

DESCRIPTION

This variable contains the raw count representation of the clock pulses sent to the MDrive. Counter 1 may be preset if necessary.

USAGE	UNITS	RANGE	DEFAULT
C1=<counts>	Motor Counts	-2147483648 to 2147483647	0

EXAMPLE:

C1=20000 'Set Counter 1 to 20000 motor counts
 PR C1 'Print the value of C1 to the terminal screen

RELATED COMMANDS: C2, P

MNEMONIC	FUNCTION	TYPE	USAGE
C2	Counter 2 (Encoder Counts)	Motion Variable	P/I R/W

DESCRIPTION

This variable contains the raw count representation of the integral 512 line encoder. Counter 2 may be preset if necessary.

USE	UNITS	RANGE	DEFAULT
C2=<counts>	Encoder Counts	-2147483648 to 2147483647	0

EXAMPLE:

C2=512 'Set Counter 2 to 512 encoder counts
 PR C2 'Print the value of C2 to the terminal screen

RELATED COMMANDS: C1, EE, P

MNEMONIC	FUNCTION	TYPE	USAGE
CK	Check Sum Enable	Flag	P/I R/W

DESCRIPTION

CK=1 puts the MDI into Check Sum Mode. When enabled, all communications with the MDI require a Check Sum to follow all commands. The Check Sum is the 2's complement of the 7 bit sum of the ASCII value of all the characters in the command OR'd with 128 (hex = 0x80). The command will be acknowledged with a NAK (15) if the Check Sum is incorrect or an ACK (6) when the command is correctly processed (no error).

USE	DEFAULT
CK=<1/0>	0

EXAMPLE:

MR 1		
77 82 32 49	'Decimal Value	Once you have the result, add the Check Sum value of 144 to your string, (to create the symbol of 144 in your string press <Alt> 0144). The MDrive should respond with an Ack or Nak (6 Hex for Ack and 15 Hex for Nak).
4D 52 20 31	'Hex	
77 + 82 + 32 + 49 = 240	'Add decimal values together	
1111 0000 240	'Change 240 decimal to binary	
0000 1111	'1's complement	
0001 0000	'Add 1 (results in the 2's complement)	
1000 0000	'OR result with 128	
1001 0000 144	'result Check Sum value	

RELATED COMMANDS: BD

MNEMONIC	FUNCTION	TYPE	USAGE
CL	Call Subroutine	Program Instruction	P

DESCRIPTION

This function can be used to invoke a subroutine within a program. This allows the user to segment code and call a subroutine from a number of places rather than repeating code within a program.

There are two parameters to the CL instruction. The first specifies the program address or label of the subroutine to be invoked if the second parameter, the condition, is true. If the second parameter is not specified, the subroutine specified by the first parameter is always invoked. The condition parameter can include flags as well as logical functions that are to be evaluated.

The subroutine should end with a RT (RET) instruction. The RT instruction will cause program execution to return to the line following the CL instruction.

USE
CL <addr/label, cond>

EXAMPLE:

CL 256, I1=1 'Call subroutine at program line 256 if Input 1 is TRUE
 CL JK 'Call subroutine labeled JK

RELATED COMMANDS: RT

MNEMONIC	FUNCTION	TYPE	USAGE
CP	Clear Program	Program Instruction	I

DESCRIPTION

This instruction will clear the program space in the EEPROM as specified by the instruction parameter. Programs are stored directly to the EEPROM and executed from there.

USE

CP <addr/label>

EXAMPLE:

CP 256 'Clear program space beginning at line 256 to the end of program space
 CP 'Clear all of program space

RELATED COMMANDS: —

MNEMONIC	FUNCTION	TYPE	USAGE
D	Deceleration	Motion Variable	P/I R/W

DESCRIPTION

The D variable sets the peak deceleration of the MDrive in steps per second². That is, steps per second, per second. If the D was set at 76800 microsteps per second² the motor would decelerate at a rate of 76800 microsteps per second, every second. If the MDrive was running at a maximum velocity of 768000 microsteps per second it would take 10 seconds to decelerate.

USE

USE	UNITS	RANGE	DEFAULT
D=<decl>	Steps/sec ²	0 to 1525878997	1000000

EXAMPLE:

D=20000 'set acceleration to 20000 step/sec²
 D=A 'set deceleration equal to acceleration

RELATED COMMANDS: A,

MNEMONIC	FUNCTION	TYPE	USAGE
D1-D5	Digital Input Filtering	I/O Variable	P/I R/W

DESCRIPTION

This variable will set the digital filtering to be applied to the selected input 1 - 5. The input must be stable for "time" amount of milliseconds before a change in state is available.

USE

USE	UNITS	RANGE
D <1-5>=<time>	Milliseconds	0 to 255

EXAMPLE:

D1=0 'no debounce
 D4=150 '150 mSec of filtering

RELATED COMMANDS: I1-I5

MNEMONIC	FUNCTION	TYPE	USAGE
DB	Encoder Deadband	Setup Variable	P/I R/W

DESCRIPTION

This variable defines the plus (+) and minus (-) length of the encoder deadband in encoder counts.
When the encoder is enabled, a move is not completed until motion stops within DB.

USE	UNITS	RANGE	DEFAULT
DB=<counts>	Encoder Counts	0 to 65000	1

EXAMPLE:

DB=5 ‘Set Encoder Deadband to ± 5 encoder counts

RELATED COMMANDS: EE, C2, SF, SM, ST, PM

MNEMONIC	FUNCTION	TYPE	USAGE
DC	Decrement Variable	Program Instruction	P/I

DESCRIPTION

The DC instruction will decrement the specified variable by one.

USE	UNITS	RANGE	DEFAULT
DC <var>			

EXAMPLE:

DC R1 ‘Decrement User Register 1

RELATED COMMANDS: IC

MNEMONIC	FUNCTION	TYPE	USAGE
DE	Drive Enable Flag	Setup Flag	P/I R/W

DESCRIPTION

The DE flag enables or disables the drive portion of the MDrive Motion Control.

USE	UNITS	RANGE	DEFAULT
DE= <0/1>			1 (Enabled)

EXAMPLE:

DE=0 ‘Disable drive
DE=1 ‘Enable drive

RELATED COMMANDS: —

MNEMONIC	FUNCTION	TYPE	USAGE
DN	Device Name	Setup Variable	P/I R/W

DESCRIPTION

The DN Variable stores the device name to be used when the MDrive is to be addressed in party mode operation. The name is only used when party mode communications is being used (PY = 1).
All MDrive system nodes will respond if the name in a command is given as “*”.
When the name is changed it must be saved into the nonvolatile memory if it is to be used in later sessions without being changed again.
See Appendix A: ASCII table for decimal codes.

USE	UNITS	RANGE	DEFAULT
DN=<“char”>	ASCII Characters	a-z, A-Z, 0-9	!

EXAMPLE:

DN=“A” or 65 ‘Set the device name to the character A

RELATED COMMANDS: PY, S

MNEMONIC	FUNCTION	TYPE	USAGE
E	End Program Execution	Program Instruction	P

DESCRIPTION

Stops the execution of a program.

USE

E

EXAMPLE:

```
PG 100      'Start program at line 100
LB J2      'Label Program J2
MR 20000   'move relative 20000 motor counts
H          'hold until motion stops
MR -20000  'move relative -20000 motor counts
H          'hold until motion stops
E          'End program execution
PG         'exit program mode
```

RELATED COMMANDS: PG, EX

MNEMONIC	FUNCTION	TYPE	USAGE
EE	Encoder Enable Flag	Setup Flag	P/I R/W

DESCRIPTION

The EE flag enables or disables the optional encoder mode of the MDrive Motion Control. When in Encoder Mode, all programming is done by Encoder Pulses. The 512 line Encoder generates pulses in a Quadrature format which results in 2048 pulses per revolution. (See Programming With the Optional Encoder Enabled in Section 2.2.)

USE

EE= <0/1>	DEFAULT 0 (Disabled)
-----------	-------------------------

EXAMPLE:

```
EE=0      'Disable encoder mode
EE=1      'Enable encoder mode
```

RELATED COMMANDS: DB, C2, SF, SM, ST, PM

MNEMONIC	FUNCTION	TYPE	USAGE
EF	Error Flag	Status Flag	P/I R

DESCRIPTION

The Error flag will indicate whether or not an error condition exists. It is automatically cleared when a new program is executed. The only way to manually clear the EF flag is to read the value of the ER variable or set ER=0

There is an instruction, OE, which allows the user to specify the execution of a subroutine in the program memory when an error occurs. The subroutine might contain instructions to read the ER variable which would clear the EF flag.

USE

PR EF	RESPONSE 0 = No Error Exists 1 = Error Condition Exists
-------	---

EXAMPLE:

```
PR EF      'read the state of the error flag
```

RELATED COMMANDS: ER, OE

MNEMONIC	FUNCTION	TYPE	USAGE
EM	Echo Mode Flag	Setup Flag	P/I R/W

DESCRIPTION

The Echo Mode Flag will set the full/half duplex configuration of the RS-485 channel. 0=Full Duplex (default), 1=Half Duplex.

USE	DEFAULT
EM= <0-3>	0 (Full Duplex)

EXAMPLE:

- EM=0 'Echo all information back over communications line. CR/LF Indicates Command Accepted (Full Duplex).
- EM=1 'Don't echo the information, only send back prompt. CR/LF Indicates Command Accepted (Half Duplex).
- EM=2 'Does not send back prompt, only responds to PRINT and LIST commands.
- EM=3 'Saves Echo in Print Queue then executes Command. Prints after execution.

RELATED COMMANDS: BD

MNEMONIC	FUNCTION	TYPE	USAGE
ER	Error Number Variable	Status Variable	P/I R/W

DESCRIPTION

The ER variable indicates the program error code for the most recent error that has occurred in the MDrive Motion Control. The ER variable must be read or set to zero to clear the EF flag.

See Appendix A of this document for a complete listing of MDrive Motion Control Error Codes.

USE	RESPONSE
PR ER	<numerical error code>

EXAMPLE:

- PR ER 'read the error number

RELATED COMMANDS: EF, OE

MNEMONIC	FUNCTION	TYPE	USAGE
EX	Execute Program	Program Instruction	I

DESCRIPTION

Execute program at a specified address or label using a selected trace mode. Used in immediate mode.

There are three modes of program execution.

- Mode 0** Normal execution, is specified by a mode of 0 (or simply leaving the mode blank).
- Mode 1** Trace mode is specified by a mode of 1. This means that the program executes continuously until the program END is encountered, but the instructions are "traced" to the communications port so the user can see what instructions have been executed.
- Mode 2** Single step mode is specified by a mode of 2. In this mode, the user can step through the program using the space bar to execute the next line of the program. The program can be resumed at normal speed in this mode by pressing the enter key.

USE	MODES
EX <addr/label>,<mode>	<mode> = 0: run program normally <mode> = 1: run program in trace mode <mode> = 2: run program in single-step mode

EXAMPLE:

- EX 127 'execute program at line 127 normally
- EX 127,1 'execute program at line 127 in trace mode

RELATED COMMANDS: PG, E

MNEMONIC	FUNCTION	TYPE	USAGE
FT	Factory Test	Status Variable	I

DESCRIPTION Factory Test

USE For Factory Use Only

MNEMONIC	FUNCTION	TYPE	USAGE
FD	Factory Defaults	Program Instruction	I

DESCRIPTION Returns MDI to factory default settings.

USE FD <IMS Copyright sign on message> "Copyright 2001-2003 by Intelligent Motion Systems, Inc."

EXAMPLE:
FD^M

RELATED COMMANDS:

MNEMONIC	FUNCTION	TYPE	USAGE
H	Hold Program Execution	Program Instruction	P

DESCRIPTION The hold instruction is used in a program to suspend program execution. If no parameter is specified the execution of the program will be suspended while motion is in progress. This will typically be used following a MA, MR, HI or HM instruction. A time in milliseconds may be placed as a parameter to the hold instruction, This will suspend program execution for the specified number of milliseconds.

USE H <time> 'Blank or 0 - hold while moving, 1 - 65000 Milliseconds.

EXAMPLE:

```
'example 1
MA 20000      'move absolute 20000 motor units
H             'hold program execution until motion completes
MA -20000    'move absolute -20000 motor units
H             'hold program execution until motion completes

'example 2
O2=1         'set output 2 HIGH
H 1000       'hold 1 second (1000 Milliseconds)
O2=0         'set output 2 LOW
```

RELATED COMMANDS: PG, E

MNEMONIC	FUNCTION	TYPE	USAGE
HC	Hold Current	Setup Variable	P/I R/W

DESCRIPTION This variable defines the motor holding current in percent.

USE HC=<PERCENT> UNITS PERCENT RANGE 0 TO 100 DEFAULT 5

EXAMPLE:
HC=5 'Set motor holding current to 5%

RELATED COMMANDS: HT, RC

MNEMONIC	FUNCTION	TYPE	USAGE
HI	Home to Index Mark	Motion Instruction	P/I

DESCRIPTION

This instruction will find the the encoder index mark. There are four combinations for this command. (See Use below.)

- 1) Speed (S): Specifies the direction and speed that the axis will move until the index mark is found (VM).
- 2) Creep (C): Specifies the direction and speed that the axis will move off the index mark until it becomes inactive again (VI).

When HI is executed, the axis moves in the direction specified by the (S) at VM until it reaches the index mark. It then creeps off of the index in the direction specified by the sign of (C) at VI. Motion is stopped as soon as the index changes state.

USE

HI=<type> TYPES
1: S- C+, 2: S- C-, 3: S+ C-, 4: S+ C+

EXAMPLE:

HI=2 ‘Find index mark at VM in the minus direction, Creep off at VI in the minus direction

RELATED COMMANDS: VM, VI, EE, I6, HM

MNEMONIC	FUNCTION	TYPE	USAGE
HM	Home to Home Switch	Motion Instruction	P/I

DESCRIPTION

This instruction will find the selected I/O switch assigned to “Home”.

- 1) Speed (S): Specifies the direction and speed that the axis will move until the switch is activated (VM).
- 2) Creep (C): Specifies the direction and speed that the axis will move off the switch until it becomes inactive again (VI).

When HM is executed, the axis moves in the direction specified by the sign of speed at VM. It then creeps off of the switch in the direction specified by the sign of creep at VI. Motion is stopped as soon as the switch becomes deactivated.

The diagram on the following page illustrates the different scenarios possible during the Homing (HM) sequence. The diagrams represent the four HM commands. Below are the four combinations of the HM command.

- HM=1 Slew at VM in the minus direction and Creep at VI in the plus direction.
- HM=2 Slew at VM in the minus direction and Creep at VI in the minus direction.
- HM=3 Slew at VM in the plus direction and Creep at VI in the minus direction.
- HM=4 Slew at VM in the plus direction and Creep at VI in the plus direction.

The key to the diagrams is as follows.

- 1 Slew at VM to find the Home Switch.
- 2 Decelerate to zero (0) after finding the Home Switch.
- 3 Creep at VI away from the Home Switch.
- 4 Stop when at the edge of the Home Switch.

USE

HM=<type> TYPES
1: S- C+, 2: S- C-, 3: S+ C-, 4: S+ C+

EXAMPLE:

HM=3 ‘Find home switch at VM in the plus direction, Creep off at VI in the minus direction

RELATED COMMANDS: VM, VI, S1-S4, HI

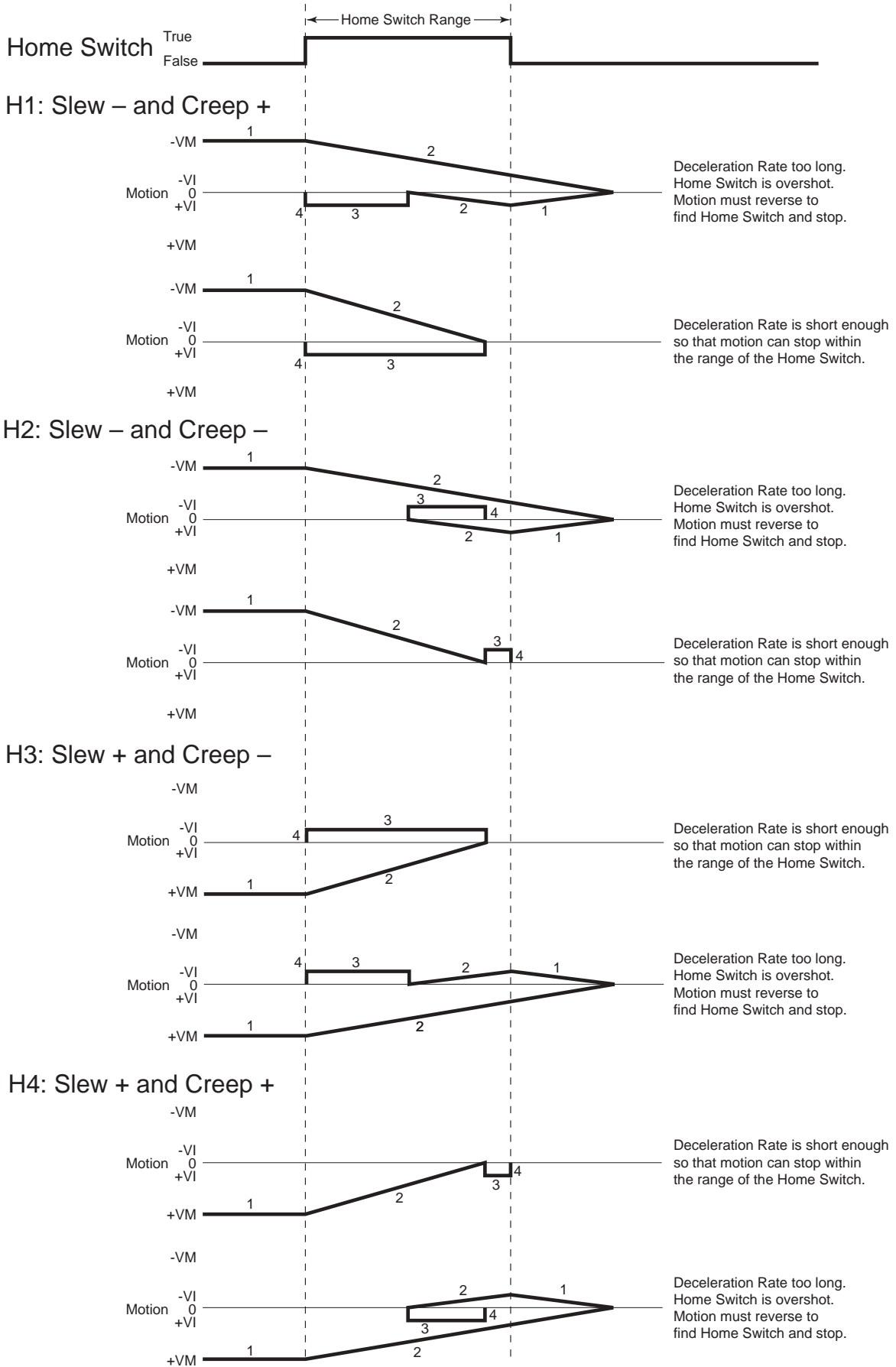

MNEMONIC	FUNCTION	TYPE	USAGE
HT	Hold Current Delay Time	Setup Variable	P/I R/W

DESCRIPTION

The HT variable sets the delay time in milliseconds between the cessation of motion and when the MDrive Motion Control shifts to the holding current level specified by the HC (Motor Holding Current) variable. The delay time is also effected by the MT (Motor Settling Delay Time) variable in that the total time from motion ceasing to current change is represented by the sum of MT + HT

USE	UNITS	RANGE	DEFAULT
HT=<time>	milliseconds	0 to 65000	500

EXAMPLE:

HT=1500 ‘Set hold current delay time to 1.5 seconds

RELATED COMMANDS: HC, MT, RC

MNEMONIC	FUNCTION	TYPE	USAGE
I1 - I4	Read Input	I/O Variable	P/I R

DESCRIPTION

This variable will read the state of the specified input 1 - 4. Can be used with PR (Print), BR (Branch) and CL (Call Subroutine) instructions. Can also be used with R1-R4 and User Variables.

The value of the bit state will be dependant on active (low/high) state of the input, specified by the S<1-4> variable.

USE

PR I<1-4>
BR <addr>, I<1-4>=<1/0>
CL <addr>, I<1-4>=<1/0>

EXAMPLE:

PR I2 ‘Print the state of Input 2 to the Terminal Screen
BR 128, I3=1 ‘Conditional branch to program line 128 if Input 3 = 1
CL 432, I4=0 ‘Call subroutine at line 432 if Input 4 = 0

RELATED COMMANDS: IN, O1-O4, PR, S1-S4

MNEMONIC	FUNCTION	TYPE	USAGE
I5	Read Analog Input	I/O Variable	P/I R

DESCRIPTION

This variable will read the value of the voltage seen on the Analog Input. Can be used with PR (Print), BR (Branch) and CL (Call Subroutine) instructions. The value read will be between 0 and 1028.

USE

PR I5
 BR <addr/label>, I5=<0 - 1028>
 CL <addr/label>, I5=<0 - 1028>

EXAMPLE:

PR I5 'Print the value of the Analog Input to the Terminal Screen
 BR K1, I5=512 'Branch to Program labled K1 if Analog Input = 512
 CL 432, I5=0 'Call subroutine at line 432 if Analog Input = 0

RELATED COMMANDS: BR, CL, PR

MNEMONIC	FUNCTION	TYPE	USAGE
I6	Read Encoder Index Mark	I/O Variable	P/I R

DESCRIPTION

This variable will read the on/off state of the Encoder Index Mark. Can be used with PR (Print), BR (Branch) and CL (Call Subroutine) instructions. The value read will be 0 (off mark) or 1 (on mark).

USE

PR I6
 BR <addr/label>, I6=<0/1>
 CL <addr/label>, I6=<0/1>

EXAMPLE:

PR I6 'Print the on/off state of the encoder index mark
 BR K1, I6 'Branch to Program labled K1 if encoder index mark is TRUE
 CL 432, I6=0 'Call subroutine at line 432 if I6=0

RELATED COMMANDS: BR, CL, PR

MNEMONIC	FUNCTION	TYPE	USAGE
IC	Increment Variable	Program Instruction	P/I

DESCRIPTION

The IC instruction will increment the specified variable by one.

USE

IC <var>

EXAMPLE:

IC R4 'Increment User Register 4

RELATED COMMANDS: IC

MNEMONIC	FUNCTION	TYPE	USAGE
IN	Read Inputs 1-4 As 1 Value	I/O Variable	P/I R

DESCRIPTION

This keyword will read the binary state (unprocessed by S<1-4>) of inputs 1-4 and print them as a decimal value. When used thus, Input 1 is the Least Significant Bit (LSb) and Input 4 is the Most Significant Bit (MSb). It may be used in conjunction with the R1-R4 (User Registers), PR (Print), BR (Branch) and CI (Call Subroutine) instructions. The value is a function of the actual state of the IO where 1 = +V and 0 = Ground. (Not a function of the active state defined in S1 to S4 variables).

USE

PR IN
BR IN=<0-15>
CL IN=<0-15>

EXAMPLE:

PR IN 'Print the state of Inputs 1-4 to the Terminal Screen
BR 128, IN=8 'Conditional branch to program line 128 if the binary state of Inputs 1-4 = 8 (1000)
CL 432, IN=13 'Call subroutine at line 432 if the binary state of Inputs 1-4 = 13 (1101)

RELATED COMMANDS: I1-5, O1-O5, PR, S1-S4

MNEMONIC	FUNCTION	TYPE	USAGE
IP	Initialize Parameters	Instruction	P/I

DESCRIPTION

The IP instruction will return all of the MDrive Motion Control parameters to their stored values.

USE

IP

EXAMPLE:

IP

RELATED COMMANDS: CP, S

MNEMONIC	FUNCTION	TYPE	USAGE
JE	Jog Enable	Setup Flag	P/I R/W

DESCRIPTION

The will enable Jog Mode if IO are set for Jog Plus and/or Jog Minus. States are 0=Disabled, 1=Enabled.

USE

JE= <0/1>

DEFAULT
0 (Disabled)

EXAMPLE:

JE=0 'Disable Jog Mode

JE=1 'Enable Jog Mode

RELATED COMMANDS: I5

MNEMONIC	FUNCTION	TYPE	USAGE
L	List Program Space	Instruction	I

DESCRIPTION

The L instruction will print the contents of program space beginning at the specified address to the end. If no address is specified it will list beginning at line 1.

USE

L

L <addr/label>

EXAMPLE:

L 128 'display contents of program space beginning at line 128

RELATED COMMANDS: —

MNEMONIC	FUNCTION	TYPE	USAGE
LB	Label Program/Subroutine	Instruction	P/I R/W

DESCRIPTION

The LB, or Label Instruction, allows the user to assign a 2 character name to a program, branch process within a program or subroutine.

The restrictions for this command are:

- 1] A label cannot be named after a MDrive Motion Control Instruction, Variable or Flag.
- 2] The first character must be alpha, the second character may be alpha-numeric.
- 3] A label is limited to two characters.
- 4] A program labeled SU will run on power-up

USE

LB <char><char>

EXAMPLE:

PG 100 'start program at adress 100

LB J0 'Label program J0

RELATED COMMANDS: BR, CL, EX, TI, TP, L, CP

MNEMONIC	FUNCTION	TYPE	USAGE
LK	Lock User Program	Setup Flag	I R/W

DESCRIPTION

This flag allows the user to lock the program from being listed or modified. It can only be reset by clearing the entire program space: CP (no address). If CP addr, L (addr) or PG addr are entered, then error 44 (Program Locked) will be set and nothing else will happen.

To clear LK, don't save (S) then do a Ctrl-C or Cycle Power and the LK will be reset to previous unlocked state. (Program is automatically stored in NVM as it is entered.) Or you may clear program (CP). This will clear the program and reset LK to 0 in NVM as well as in local ram.

USE	DEFAULT
LK=<0/1>	0 (Disabled)

RELATED COMMANDS: CP, L

MNEMONIC	FUNCTION	TYPE	USAGE
LM	Limit Stop Mode	Motion Variable	R/I R/W

DESCRIPTION

The LM variable specifies the Limit Stop Mode for the MDrive. There are six LM modes. They are as follows.

- LM=1 Normal Limit function with a decel ramp.
The I/O must be set for Limits. If the limit switch in the direction of travel is reached, the motion will decel to a stop. That is, the plus limit works only in the plus direction of travel and the minus limit works only in the minus direction of travel.
In the illustration below, the Limit is activated at a given position but because of the deceleration rate the motion continues for the duration of the deceleration time. This position may be beyond the trip point of the limit and a subsequent move in the same direction will not stop. A crash may be imminent. If the limit is activated and maintained the software will allow motion *only* in the opposite direction.
If Homing (HM) is active and a limit is reached, the motion will decel to a stop and then reverse direction and seek the Homing Switch. If the Homing Switch is not activated on the reverse and the opposite limit is reached all motion will stop with a decel ramp. (See HM)
It is possible for the Home Switch to be overshoot because of long decel time. Whenever the Homing sequence is activated, a short decel time should be used.
- LM=2 A Limit stops all motion with a decel ramp but no Homing.
- LM=3 A Limit will stop all motion with a decel ramp and stop program execution.
- LM=4 Functions as LM=1 but with no deceleration ramp.
- LM=5 Functions as LM=2 but with no deceleration ramp.
- LM=6 Functions as LM=3 but with no deceleration ramp.

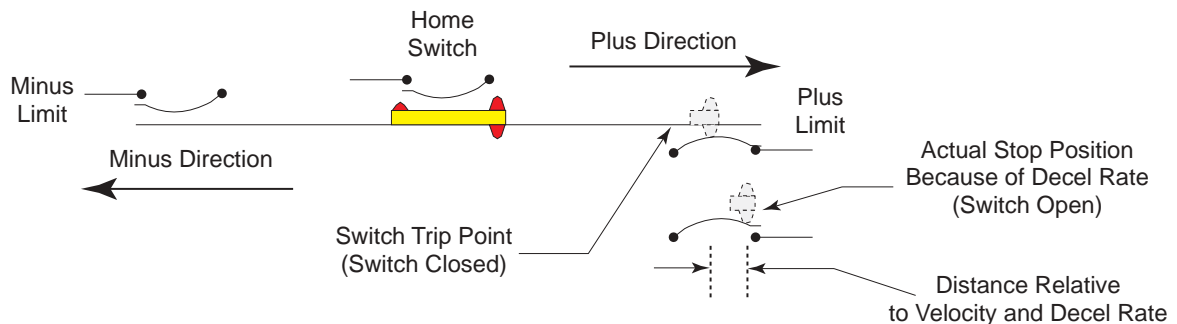

USE	DEFAULT
LM=<1-6>	1

RELATED COMMANDS: HI, HM, JE, MA, MR, SL

MNEMONIC	FUNCTION	TYPE	USAGE
MA	Move To Absolute Position	Motion Instruction	P/I

DESCRIPTION

Set mode for absolute move and move to an absolute position relative to (0) zero. MD (Current Mode) will be set to MA.
If flag is true, then DN will be sent out when move is complete.

USE	UNITS
MA ±pos, <flag>	motor counts

EXAMPLE:

MA 51200 'move motor to absolute position 51200 in positive direction
MA -51200 'move motor to absolute position 51200 in negative direction

RELATED COMMANDS: MD, MR, MS, P

MNEMONIC	FUNCTION	TYPE	USAGE
MD	Motion Mode	Motion Variable	P/I R

DESCRIPTION

Indicates what the last motion command was, so that when just a number is entered, then it will read MD to define the new motion.

USE	MD

EXAMPLE:

MA 200000 'move absolute 200000 steps, set current mode to MA
-200000 'move absolute -200000 steps

MR 1000000 'move relative 1000000 steps, set current mode to MR
-1000000 'move relative -1000000 steps

SL 20000 'slew 20000 steps/sec. set current mode to SL
-10000 'slew 10000 steps/sec in minus direction

PR MD return current mode setting

RELATED COMMANDS: MD, MR, MS, P, PR, SL

MNEMONIC	FUNCTION	TYPE	USAGE
MR	Move To Relative Position	Motion Instruction	P/I

DESCRIPTION

Set mode for relative move and move a relative distance. MD (Current Mode) will be set to MR.
If flag is true, then DN will be sent out when move is complete..

USE	UNITS
MR ±distance, <flag>	motor counts

EXAMPLE:

MR 200000 'move motor 200000 motor counts positive direction
MR -50000 'move motor 50000 motor counts in a negative direction

RELATED COMMANDS: MD, MA, MS, P

MNEMONIC	FUNCTION	TYPE	USAGE
MS	Microstep Resolution	Motion Variable	P/I R/W

DESCRIPTION

The MS variable controls the microstep resolution of the MDrive Motion Control. There are 14 parameters that can be used with this variable, 8 binary and 6 decimal. The table below illustrates the parameter settings and their associated resolutions for the 1.8° stepping motor used with the MDrive Motion Control.

The MS parameters given in the table below are the only valid parameters that will be accepted by the MDrive.

USAGE	DEFAULT
MS=<parameter>	256

EXAMPLE:

- MS=4 ‘Set Microstep Resolution to 4 Microsteps/Step (800 Steps/Rev)
- MS=50 ‘Set Microstep Resolution to 50 Microsteps/Step (10000 Steps/Rev)
- PR MS ‘Print the MS setting to the terminal

Microstep Resolution Settings (MS)	
MS= (Microsteps/Step)	Steps/Rev
Binary Microstep Resolution Settings	
2	400
4	800
8	1,600
16	3,200
32	6,400
64	12,800
128	25,600
256	51,200
Decimal Microstep Resolution Settings	
5	1,000
10	2,000
25	5,000
50	10,000
125	25,000
250	50,000

Table 2.10: Microstep Resolution Settings

MNEMONIC	FUNCTION	TYPE	USAGE
MT	Motor Settling Delay Time	Motion Variable	P/I R/W

DESCRIPTION

Specifies the motor settling delay time in milliseconds. MT allows the motor to settle following a move. This is the time between moves if consecutive motions are executed.

USE	UNITS	RANGE	DEFAULT
MT=<time>	milliseconds	0 to 65000	0

EXAMPLE:

- MT=50 ‘Set motor settling delay time to 50 milliseconds

RELATED COMMANDS: HC, HT, RC

MNEMONIC	FUNCTION	TYPE	USAGE
MV	Moving Flag	Moving Flag	P/I R

DESCRIPTION

Output is true when motor is moving.

USE	UNITS	RANGE	DEFAULT
PR MV		0/1	0

EXAMPLE:

PR MV^M

RELATED COMMANDS:

MNEMONIC	FUNCTION	TYPE	USAGE
O1 - O4	Set Output Logic State	I/O Variable	P/I W

DESCRIPTION

This variable will set the logic state of the specified output to 1 or 0. When used with the PR (Print) instruction it will print the state of the specified output to the terminal screen.

The value of the bit state will be dependant on the active (low/high) state of the input, specified by the S<1-4> variable.

USE	
	O<1-4>=<0/1>

EXAMPLE:

O4=1 'Set Output 4 to 1

RELATED COMMANDS: OT, I1-I4, PR, S1-S4

MNEMONIC	FUNCTION	TYPE	USAGE
OE	On Error Handler	Instruction	P/I

DESCRIPTION

When an error occurs in a program or due to an immediate command, the specified subroutine is called. If a program was running when the fault occurs, once the error routine completes, program execution continues with the instruction after the one that caused the error. A program need not be running for the subroutine specified by OE to run.

The ON ERROR function is disabled by setting the address parameter to 0 or resetting the MDrive Motion Control.

USE	
	OE <address>

EXAMPLE:

'the following subroutine will set an output high upon an error

```
PG 100      'Start sub at address 100
OE E1      'On Error go to E1
LB E1      'label subroutine E1
O3=1      'Set Output 3 to Logic 1
RT        'Return from subroutine
E          'End program
PG        'Return to immediate mode
```

RELATED COMMANDS: EF, ER

MNEMONIC	FUNCTION	TYPE	USAGE
OT	Set Outputs 1-4 As 1 Value	I/O Variable	P/I W

DESCRIPTION

The OT variable allows the user to set Outputs 1-4 (unprocessed by S<1-4>) as one 4 bit binary value. The value is entered in decimal, with a range of 0-15 in binary where Output 1 will be the LSb and Output 4 will be the MSb.

Example: OT=12

Output 4 = 1

Output 3 = 1

Output 2 = 0

Output 1 = 0

USE

OT=<0-15>

PR OT

EXAMPLE:

OT=7 'Set outputs 1-4 to O1=1, O2=1, O3=1, O4=0

RELATED COMMANDS: I1-I4, S1-S4

MNEMONIC	FUNCTION	TYPE	USAGE
P	Position Counter	Motion Variable	P/I R/W

DESCRIPTION

This instruction is used to set or print the value of the MDrive Motion Control position counter. The position will read in Motor Counts from C1 (Counter 1) by default, if encoder functions are enabled, the position counter will read in Encoder Counts from C2 (Counter 2).

The main difference in the relationship of the two counters is that where C1 is variable, the value of each count in terms of distance moved is based upon the MS, or microstep resolution setting, C2 will always be 2048 counts per motor revolution, regardless of the microstep resolution setting.

Modifying P in essence changes the frame of reference for the axis. P will probably be set once during system set up to reference or "home" the system.

USE

P <±position>

PR P

UNITS

Steps

RANGE

-2147483648 to 2147483647

EXAMPLE:

P=0 'Clear position counter, set to 0

PR P 'Print the state of the position counter

RELATED COMMANDS: C1, C2

MNEMONIC	FUNCTION	TYPE	USAGE
PC	Position Capture At Trip	Program Instruction	I

DESCRIPTION

Captures motor or encoder position at activation.

USE

PC

UNITS

Motor/ Encoder Counts

RANGE

Signed 32 bit

EXAMPLE:

PR PC^M 'Display captured position

RELATED COMMANDS:

MNEMONIC	FUNCTION	TYPE	USAGE
PS	Pause Program Instruction	Instruction	I

DESCRIPTION

This instruction is used to pause an executing program and invoke normal deceleration of any motion being executed to Zero. Immediate mode instructions are allowed while a program is in a paused state. To resume the program the RS instruction is used.

USE

PS

EXAMPLE:

PS

RELATED COMMANDS: RS, S1-S4

MNEMONIC	FUNCTION	TYPE	USAGE
PY	Party Mode Enable Flag	Setup Flag	P/I R/W

DESCRIPTION

The party flag must be set to 1 if the MDrive Motion Control is being used in a multidrop system.

When Party Mode is enabled, each MDrive in the system must be addressed by the host computer by using the device name specified by the DN instruction. This name will precede any command given to a specified unit in the system and be terminated with a Control J (CTRL + J). One CTRL + J must be issued after power up or entering the Party Mode to activate the Party Mode. By default the DN assigned at the factory is the exclamation character (!).

The global name is the asterisk character (*). Commands preceded by this character will be recognized by every MDrive in the system.

After the Party Mode is enabled, send CTRL + J (^J) to activate it. Type commands with Device Name (DN) and use CTRL + J as the Terminator.

USE

PY= <0/1>

DEFAULT

0 (Disabled)

EXAMPLES:

PY=0 'Party Mode Disabled (Default)

PY=1 'Party Mode Enabled

PARTY MODE

- DN="X"<enter> 'Enter Device Name
- PY=1<enter> 'Set Party Mode
- <CTRL+J> 'Activate Party Mode
- XPR P<CTRL+J> 'Print Position (MDI responds with present position)
- XSL 1000<CTRL+J> 'Slew 1000 step/sec.
- XSL 0<CTRL+J> 'Stops Motion
- XS<CTRL+J> 'Save parameters
- XPY=0<CTRL+J> 'Deactivate Party Mode
- PR AL<enter> 'Print all Parameters
- S<enter> 'Save parameters

RELATED COMMANDS: DN

MNEMONIC	FUNCTION	TYPE	USER	
			P/I	R/W
R1 - R4	User Registers	User Variable		

DESCRIPTION

The MDrive Motion Control has four 32 bit user registers to contain numerical data. These registers may contain up to 11 digits including the sign and may be used to store and retrieve data to set variables, perform math functions, store and retrieve moves and set conditions for branches and subroutine calls.

USE	RANGE	DEFAULT
R<x>=<data>	-2147483647 to 2147483647	0

EXAMPLES:

```

R1=50000      'Set Register 1 to 50000
'Subroutine using a register value to perform a math function that will display axis position in revolutions rather than motor steps
'****variable setup****
MS=256        'set resolution to 256 microsteps/step
P=0           'set position counter to 0
R1=51200/1    '51200 steps = 1 rev
'****Program Content****
MR R1         'move relative 102400 steps
H             'Hold execution until motion stops
CL 348        'call subroutine at address 348
'****Sub at address 348****
R2=P          'set Register 2 equal to the position counter
R3=R2/R1      'set Register 3 equal to R2/R1
PR "Position = ", R3, "Revolutions";
H 60000       'hold for 1 minute
RT            'return to prog

```

RELATED COMMANDS: —

MNEMONIC	FUNCTION	TYPE	USAGE	
			P/I	R/W
RC	Run Current	Setup Variable		

DESCRIPTION

This variable defines the motor run current in percent.

USE	UNITS	RANGE	DEFAULT
RC=<percent>	Percent	1 to 100	25

EXAMPLE:

```

RC=75      'Set motor run current to 75%

```

RELATED COMMAND: HC

MNEMONIC	FUNCTION	TYPE	USAGE
RS	Resume Program Instruction	Instruction	I

DESCRIPTION

This instruction is used to resume a program that has been paused using the PS instruction. Motion will resume using the normal acceleration profiles.

USE

RS

EXAMPLE:

RS

RELATED COMMANDS: PS, S1-S4

MNEMONIC	FUNCTION	TYPE	USAGE
RT	Return From Subroutine	Instruction	P

DESCRIPTION

This instruction defines the end of a subroutine. This instruction is required and will be the final instruction in the subroutine executed by the CL instruction. When used, it will return to the program address immediately following the CL instruction which executed the subroutine.

USE

RT

EXAMPLE:

****Program****

	PG100	'enter program mode at address 100
100	MR 51200	'move relative 51200
105	H	'suspend prog. execution until motion completes
109	CL 238	'Call subroutine at address 238
238	O1=1	'set output 1 to 1
241	RT	'return from subroutine

RELATED COMMANDS: CL

MNEMONIC	FUNCTION	TYPE	USAGE
S	Save to EEPROM	Instruction	P/I

DESCRIPTION

Saves all variables and flags currently in working memory (RAM) to nonvolatile memory (NVM). The previous values in NVM are completely overwritten with the new values.

When the user modifies variables and flags, they are changed in working memory (RAM) only. If the SAVE instruction is not executed before power is removed from the control module, all modifications to variables & flags since the last SAVE will be lost.

USE

S

RELATED COMMANDS: —

MNEMONIC	FUNCTION	TYPE	USAGE
S1 - S4	Setup I/O Point Type/Active State	I/O Instruction	P/I R/W

DESCRIPTION

This instruction is used to setup the I/O type and active states for I/O points 1 - 4. Each of MDrive Motion Control I/O points 1- 4 may be programmed as either general purpose inputs and outputs, or to one of nine dedicated input functions or one of two dedicated output functions.

When programmed as inputs, these points will be sinking and may be programmed such that they are active when pulled to ground, or active when left floating. By default each point is configured as a general purpose input, active when LOW.

There are two parameters attached to this instruction: the type specifies the function of the I/O point. The second parameter sets the active state, which defines the point as LOW or HIGH TRUE.

I/O FUNCTION	FUNCTION	TYPE	ACTIVE STATE PARAMETER
INPUTS			
General Purpose Input	Multiple Usage	0	LOW = TRUE 0
Home Input	For "Homing" Sequence (See HM)	1	HIGH = TRUE 1
Limit + Input	Motion stops with DECEL, sets Motion Error 83, program continues, moves in plus direction ignored. (See OE) (See sample limit switch test program in Appendix C)	2	
Limit - Input	Motion stops with DECEL, sets Motion Error 84, program continues, moves in minus direction ignored. (See OE) (See sample limit switch test program in Appendix C)	3	
GO Input	Initiate Program Start. (<u>Always</u> at address 1)	4	
Soft Stop Input	Program and Motion Stop with DECEL	5	
Pause Input	Pause/Resume Program and Motion	6	
Jog + Input	Activate Plus Jog Input	7	
Jog - Input	Activate Minus Jog Input	8	
OUTPUTS			
General Purpose Output	Multiple Usage	16	
Moving Output	Output set if Motor is Moving (See MV)	17	
Fault Output	Output set if Fault detected (See EF)	18	
Stall	Output set if Stall detected (See ST)	19	
VCHG	Output set if Velocity Changing (See VC)	20	

USE	DEFAULT
S<1-4>=<type>,<active>	<type>=0, <active>=0

EXAMPLE:

- S1=2,0 'set i/o point 1 to a limit + function, active when LOW
- S4=17,1 'set i/o point 4 as moving output, active when HIGH

RELATED COMMANDS: I1-4, IN, O1-4, OT, D1-D4, PS, RS, EF, ST, VC

MNEMONIC	FUNCTION	TYPE	USAGE
S5	Set/Print I/O Point 5	I/O Instruction	P/I R/W

DESCRIPTION

This I/O point differs from I/O points 1-4 in that it is factory configured as a 0 - 5 V Analog Input with 10 bit A/D resolution.

I/O FUNCTION	TYPE	USAGE
0-5V Analog Input		9
4-20 mA Analog Input		10

RELATED COMMANDS: I5, JE

MNEMONIC	FUNCTION	TYPE	USAGE
SF	Stall Factor Variable	Encoder Variable	P/I R/W

DESCRIPTION

If the encoder is enabled (EE = 1) and the encoder differs from the motor by more than the specified factor, a STALL is indicated. If SM is set to 0, then the motor will be stopped when a STALL is detected.

USE	UNITS	RANGE	DEFAULT
SF=<counts>	Encoder counts	0 to 65000	10

EXAMPLE:

SF=20 'Set the stall factor to twenty counts. If the motor falls behind by more than 20 encoder counts a stall is detected.

RELATED COMMANDS: EE, SM, ST

MNEMONIC	FUNCTION	TYPE	USAGE
SL	Slew Axis Instruction	Motion Instruction	P/I

DESCRIPTION

The SL instruction will slew the axis at the specified velocity in counts per second. The axis will accelerate at the rate specified by the A (Acceleration) variable.

Note that the maximum slew velocity is independent of the maximum velocity specified by the VM variable. If a slew is commanded at a velocity greater than the setting of VM, the axis will accelerate to that velocity regardless of the setting of VM.

USE	UNITS	RANGE
SL <±velocity>	± Counts per sec	±5000000

EXAMPLE:

SL 20000 'slew the axis at 20000 counts/sec

RELATED COMMANDS: A, D, MS, MR

MNEMONIC	FUNCTION	TYPE	USAGE	
SM	Stall Detection Mode Variable	Encoder Variable	P/I	R/W

DESCRIPTION

The SM variable specifies the action which will be taken by the MDrive Motion Control when a stall is detected. When set to 0 (default) the motion will be stopped upon a stall detection. When SM=1, the motor will continue to move. In either case ST (Stall Flag) will be set.

USE	DEFAULT
SM = <0/1>	0 (Stop Motor)

EXAMPLE:

SM=0 'stop motor when a stall is detected
SM=1 'do not stop motor upon a stall

RELATED COMMANDS: EE, SF, ST, PM

MNEMONIC	FUNCTION	TYPE	USAGE	
ST	Stall Flag	Encoder Flag	P/I	R/W

DESCRIPTION

The ST flag will be set to 1 when a stall is detected. It is the responsibility of the user to reset it to zero (0).

USE	
	PR ST
	BR <addr>, ST=1
	CL <addr>, ST=1

EXAMPLE RESPONSE:

ST=0 'motor not stalled
ST=1 'motor stalled

RELATED COMMANDS: EE, SF, ST, OE

MNEMONIC	FUNCTION	TYPE	USAGE	
TE	Trip Enable Flag	Setup Flag	P/I	R/W

DESCRIPTION

This flag will enable or disable specified trip functions.

TE=0	TI Disabled	TP Disabled
TE=1	TI Enabled	TP Disabled
TE=2	TI Disabled	TP Enabled
TE=3	TI Enabled	TP Enabled

USE	DEFAULT
TE= <1-4>	0 (Trips Disabled)

EXAMPLE:

TE=1 'Enable trip on input functions

RELATED COMMANDS: I1-I4, P, S1-S4, TI, TP

MNEMONIC	FUNCTION	TYPE	USAGE
TI	Trip on Input	Variable	P/I R/W

DESCRIPTION

Sets up an input event (Trip) for the specified input. There are two parameters for the TI variable. The first specifies which input line to monitor. The second specifies the subroutine that should be executed when the input goes to true.

The TE (Trip Enable which Enables/Disables TI) is reset when a Trip occurs. TE must be re-enabled in the main program prior to the next Trip if it is to be repeated.

USE

TI=<input>,<addr/label>

EXAMPLE:

TI=2,K1 'execute subroutine labeled K1 when input 2 is active.

RELATED COMMANDS: I1-4, S1-4, TP

MNEMONIC	FUNCTION	TYPE	USAGE
TP	Trip on Position	Variable	P/I R/W

DESCRIPTION

Sets up a position event (trip) for the specified position. There are two parameters for the TP variable. The first specifies the position which will cause the event. The second specifies the subroutine that should be executed when the position is detected

The TE (Trip Enable which Enables/Disables TP) is reset when a Trip occurs. TE must be re-enabled in the main program prior to the next Trip if it is to be repeated.

USE

TP=<position>,<addr/label>

EXAMPLE:

TP=200000,300 'execute subroutine at address 300 when at position 200000

RELATED COMMANDS: P, TI, PC

MNEMONIC	FUNCTION	TYPE	USAGE
UG	Upgrade Firmware	Instruction	I

DESCRIPTION

Upgrade Firmware Instruction. Upgrade code is 2956102. This will put the MDrive in Upgrade Mode. Once set, the firmware Upgrade MUST be completed.

USE

UG 2956102

RELATED COMMANDS: —

MNEMONIC	FUNCTION	TYPE	USAGE
UV	Read User Variables	Variable	P/I R

DESCRIPTION

Read User Variables is used with the PR (Print) Instruction to read the value of all user variables

USE

PR UV

RELATED COMMANDS: , PR, VA

MNEMONIC	FUNCTION	TYPE	USAGE
V	Read Only Velocity Variable	Motion Variable	P/I R

DESCRIPTION

The velocity variable is used in conjunction with the PR (print) instruction to read the current velocity of the axis in counts per second. This variable can also be used with the BR and CL instructions to set a condition based upon a velocity. This variable can also be used in conjunction with the user registers to compute another velocity.

USE

PR V
 BR <addr>, V=<counts/sec>
 CL <addr>, V=<counts/sec>

UNITS
Counts per Second

RELATED COMMANDS: VI, VM

MNEMONIC	FUNCTION	TYPE	USAGE
VA	Create User Variable Name	Instruction	P/I R/W

DESCRIPTION

The VA instruction allows the user to assign a 2 character name to a user defined variable.

The restrictions for this command are:

- 1] A variable cannot be named after a MDrive Motion Control Instruction, Variable or Flag.
- 2] The first character must be alpha, the second character may be alpha-numeric.
- 3] A variable is limited to two characters.

USE

VA <char><char>=<value>

EXAMPLE:

VA P2 'create user var P2
 P2=20000 'set P2 to 20000

RELATED COMMANDS: UV

MNEMONIC	FUNCTION	TYPE	USAGE
VC	Velocity Changing	Motion Flag	P/I R

DESCRIPTION

Indicates that the Velocity is changing.

USE

BR <addr>, VC

RELATED COMMANDS:

MNEMONIC	FUNCTION	TYPE	USAGE	
VI	Initial Velocity Variable	Motion Variable	P/I	R/W

DESCRIPTION

Initial velocity for all motion commands. The factory default value is 1000 clock pulses per second.

The initial velocity for a stepper should be set to avoid the low speed resonance frequency and must be set lower than the pull in torque of the motor. It must also be set to a value lower than VM (Max. Velocity).

VI must be less than VM.

USE	UNITS	RANGE	DEFAULT
VI=<velocity>	Counts per sec	1 to 5000000	1000

EXAMPLE:

VI=2000 'set initial velocity to 2000 counts per second

RELATED COMMANDS: VM

MNEMONIC	FUNCTION	TYPE	USAGE	
VM	Maximum Velocity Variable	Motion Variable	P/I	R/W

DESCRIPTION

The VM variable specifies the maximum velocity in counts per second that the axis will reach during a move command.

VM must be greater than VI.

USE	UNITS	RANGE	DEFAULT
VM=<velocity>	Counts per sec	1 to 5000000	768000

EXAMPLE:

VM=51200 'set max velocity to 51200 counts per second

RELATED COMMANDS: VM

MNEMONIC	FUNCTION	TYPE	USAGE	
VR	Read Only Firmware Version	Factory Variable	P/I	R

DESCRIPTION

This variable is used in conjunction with the PR instruction to read the version of the firmware installed at the factory. If the Version number is followed by an E, the Mdrive is an Encoder Version. An I will indicate and Index version. Blank will indicate no options.

USE

PR VR

RELATED COMMANDS: —

Appendix A

ASCII TABLE

Dec	Hex	Char	Dec	Hex	Char	Dec	Hex	Char	Dec	Hex	Char
0	0	NUL	32	20		64	40	@	96	60	`
1	1	SOH	33	21	!	65	41	A	97	61	a
2	2	STX	34	22	"	66	42	B	98	62	b
3	3	ETX	35	23	#	67	43	C	99	63	c
4	4	EOT	36	24	\$	68	44	D	100	64	d
5	5	ENQ	37	25	%	69	45	E	101	65	e
6	6	ACK	38	26	&	70	46	F	102	66	f
7	7	BEL	39	27	'	71	47	G	103	67	g
8	8	BS	40	28	(72	48	H	104	68	h
9	9	TAB	41	29)	73	49	I	105	69	i
10	A	LF	42	2A	*	74	4A	J	106	6A	j
11	B	VT	43	2B	+	75	4B	K	107	6B	k
12	C	FF	44	2C	,	76	4C	L	108	6C	l
13	D	CR	45	2D	-	77	4D	M	109	6D	m
14	E	SO	46	2E	.	78	4E	N	110	6E	n
15	F	SI	47	2F	/	79	4F	O	111	6F	o
16	10	DLE	48	30	0	80	50	P	112	70	p
17	11	DC1	49	31	1	81	51	Q	113	71	q
18	12	DC2	50	32	2	82	52	R	114	72	r
19	13	DC3	51	33	3	83	53	S	115	73	s
20	14	DC4	52	34	4	84	54	T	116	74	t
21	15	NAK	53	35	5	85	55	U	117	75	u
22	16	SYN	54	36	6	86	56	V	118	76	v
23	17	ETB	55	37	7	87	57	W	119	77	w
24	18	CAN	56	38	8	88	58	X	120	78	x
25	19	EM	57	39	9	89	59	Y	121	79	y
26	1A	SUB	58	3A	:	90	5A	Z	122	7A	z
27	1B	ESC	59	3B	;	91	5B	[123	7B	{
28	1C	FS	60	3C	<	92	5C	\	124	7C	
29	1D	GS	61	3D	=	93	5D]	125	7D	}
30	1E	RS	62	3E	>	94	5E	^	126	7E	~
31	1F	US	63	3F	?	95	5F	_	127	7F	DEL

Appendix B

Error Codes

Error Code	Fault
0	No Error
I/O Errors	
1	I/O1 Fault
2	I/O2 Fault
3	I/O3 Fault
4	I/O4 Fault
5	I/O5 Fault
6	An I/O is already set to this type.
7	Tried to set an Input or defined I/O.
8	Tried to set an I/O to an incorrect I/O type.
9	Tried to write to I/O set as input or is "TYPED".
10	Illegal I/O number.
Data Errors	
20	Tried to set unknown variable or flag.
21	Tried to set an incorrect value.
22	VI set greater than or equal to VM.
23	VM is set less than or equal to VI.
24	Illegal data entered.
25	Variable or flag is read only.
26	Variable or flag is not allowed to be incremented or decremented.
27	Trip not defined.
28	Trying to redefine a program label or variable.
29	Trying to redefine an embedded command or variable.
30	Unknown label or user variable.
31	Program label or user variable table is full.
32	Trying to set a label (LB).
Program Errors	
40	Program not running.
41	Program running.
42	Illegal program address.
43	Tried to overflow program stack.
44	Program locked.
Communications Errors	
60	Tried to enter unknown command.
61	Trying to set illegal BAUD rate.
Motion Errors	
80	HOME switch not defined.
81	HOME type not defined.
82	Went to both LIMITS and did not find home
83	Reached plus LIMIT switch.
84	Reached minus LIMIT switch.
85	MA or MR not allowed while in motion.
86	Stall detected.

Appendix C

MDrive Motion Control (MDI) Program Samples

For additional MDI Program Samples, go to www.imshome.com/app_note_MDI.html

Some of these sample programs require digital and analog inputs which can be configured in several different ways. In some cases hardware such as a small mechanical switch, potentiometer or joystick may be needed. For more information please see:

Interfacing the Digital I/O

Interfacing the Analog Input

NOTE: The character ^ is used to indicate a space. Do not type this character but be sure to type the space.

Motion Sample

This is a simple motion program that sets the position counter to zero (0), moves the MDI 200000 microsteps in the plus direction and then prints the position in the Terminal Window.

CODE	DESCRIPTION
VI^750	'set initial velocity to 750 steps/sec
VM^500000	'set max velocity to 500000 steps/sec
A ^750000	'set acceleration rate to 750000 steps/sec/sec
D=A	'set deceleration rate equal to A
HC^10	'set motor hold current to 10%
RC^35	'set motor run current to 35%
PG^100	'enter program mode at address 100
LB m1	'lable program m1
P=0	'set position counter to 0
MR^200000	'set motion to relative, move 2000000
H	'hold until motion is complete
PR^P	'print position to terminal
E	'end program
PG	'exit program mode

IF THEN Sample

This program moves the MDI in the plus direction **IF** Input One (1) is low. **IF** Input 1 is high, **THEN** the MDI will reverse direction.

CODE	DESCRIPTION
PG^100	'Enter program mode at address 100
LB P1	'Label program P1
S1=0,1	'Sets I/O 1 as a general purpose input, active high
LB^M1	'Label to begin motion profile 1
MR^200000	'Move relative 200000 steps
H	'Hold until motion is complete
BR^M1,I1=1	'If input is true then branch to label M1
LB^M2	'Label to begin motion profile 2
MR^-100000	'Move relative 100000 steps
H	'Hold until motion is complete
BR^M1,I1=1	'If input is true then branch to label M1
BR^M2	'Unconditional branch to label M2
E	'End program
PG	'Exit program mode

Appendix C

MDrive Motion Control (MDI) Program Samples

Use of I/O Sample

This is another simple program that runs the MDI until Input One (1) is turned on. When Input One (1) is turned on, the MDI will stop.

CODE	DESCRIPTION
PG^100	'Enter program mode at address 100
LB^P1	'Label program ZZ
A=1000000	'Sets acceleration to 1000000 steps/second square
S1=0,1	'Sets I/O 1 as a general purpose input, active high
S5=9	'Sets I/O 5 as a 0-5V analog input
LB^WT	'Label WT for setting up wait loop
BR^M1,I1=1	'If input is active then branch to label M1
SL^0	'Sets slew speed to 0
BR^WT,I1=0	'If input is inactive then branch to label WT
LB^M1	'Label for motion profile 1
SL^15*10000	'Slew the axis at the rate of 0-1024 times 100000
BR^WT	'Unconditional branch to wait loop to scan input
E	'End program
PG	'Exit program mode

Integer Math Only (No Decimals)

This program illustrates the math capabilities of the IMS Terminal. No MDI motion occurs.

CODE	DESCRIPTION
VA^V1=10	'declare global variable V1
VA^V2=3	'declare global variable V2
VA^V3	'declare global variable V3
PG^1	'enter program mode at address 1
LB^aa	'label aa
V3=V1+V2	'add values in V1 and V2 put result into V3
PR^"V3="V3	'print the value in V3 to the terminal
H^1000	'hold program execution for 1000 milliseconds
V3=V1*V2	'multiply values in V1 and V2 put the result into V3
PR^"V3="V3	'print the value of V3 to the terminal
E	'end program
PG	'exit program mode

```
'program action
'V3=V1+V2 produces an answer of 13
'V3=V1*V2 produces an answer of 30
'V3=V1/V2 produces an answer of 3
'try typing different values of V1 and V2 and "ex aa"
'V1=35<enter>
'V2=4<enter>
"EX aa<enter>
'results
'V3=V1+V2=39
'V3=V1*V2=140
'V3=V1/V2=8
```

Appendix C

MDrive Motion Control (MDI) Program Samples

Limit Switch Test Program

This program demonstrates the use of limit switches. The MDI will rotate back and forth in both directions with a 250 mS HOLD between each reversal. If Input One (1) is high, the MDI will stop rotating in the plus direction and Error 83 will be printed in the Terminal Window. It will continue to rotate in the minus direction with the HOLD. If Input Two (2) is HIGH, the MDI will stop rotating in the minus direction and Error 84 will be printed to the Terminal Window. It will continue to rotate in the plus direction with the HOLD. Only the direction of travel monitored by the limit switch will be stopped.

Ref: Error Code 83 = Reached the Plus Limit Switch
Error Code 84 = Reached the Minus Limit Switch

CODE	DESCRIPTION
S1=2,0	'set input 1 as positive limit, low true
S2=3,0	'set input 2 as negative limit, low true
PG^I	'enter prog mode at address 1
LB^aa	'label aa
VM=51200	'set max velocity to 51200 steps/sec
MR^102400	'move positive 102400 steps
	'close switch at input 1 to
	'stop motion in the positive direction
	'and cause an error 83
	'NOTE: PROGRAM CONTINUES TO EXECUTE
	'leave switch open and program runs normal
H	'hold prog exec until motion complete
H^250	'hold prog exec for 250 milliseconds
PR^Er	'print error number to terminal window
MR^-102400	'move negative 102400 steps
	'close switch at input 2 to
	'stop motion in the negative direction
	'and cause an error 84
	'NOTE: PROGRAM CONTINUES TO EXECUTE
H	'hold prog exec until motion complete
H^250	'hold prog exec for 250 millisec
PR^Er	'print error number to terminal window
BR^aa	'branch to label aa
E	'end prog
PG	'exit prog mode
	'hit "Esc" key to stop program

Appendix C

MDrive Motion Control (MDI) Program Samples

Speed Control Via Analog Input

This program allows the user to perform speed control using the analog input on the MDI. This program will function with a potentiometer or a joystick.

CODE	DESCRIPTION
S5=9	'sets analog input to accept 0-5Vdc.
S1=0,1	'sets I/O point 1 to general purpose output
A=2000000	'acceleration set to 2000000 microsteps/sec/sec
D=2000000	'deceleration set to 2000000 microsteps/sec/sec
R4=20 'deadband value	
PG^1	'initiate program at address 1
LB^M1	'startup label. Program executes on power up
LB^ZZ	'label called ZZ
R1=I5	'register 1 set to analog input value
CL^ab	'computes new velocity by calling subroutine at label ab.
SL^R3	'slew at the value of register 3
H^10	'wait 10 milliseconds
BR^ZZ	'branch to the label called ZZ
E	'end of ZZ routine
LB ab	'routine to determine direction and remove deadband
R1=R1-508	'offset from joystick center
R2=1	'positive direction
BR^a1,R1>=0	'get dir of r1
R2=-1	'negative direction
R1=R1*R2	'get absolute value of r1
LB a1	
BR A2,R1<R4	'go to A2 routine if R1 value is less than deadband
R1=R1*1000	'scale multiplier
R3=R1*R2	'resultant R3 value for slew speed
RT	'return to command below call in ZZ routine.
LB A2	
R3=0	'sets slew velocity to zero
RT	
E	'end
PG	'exit program space

Appendix D

Recommended Cable Configurations for MDrive

Cable length, wire gauge and power conditioning devices play a major role in the performance of your MDrive.

NOTE: The length of the DC power supply cable to an MDrive should not exceed 50 feet.

Example A demonstrates the recommended cable configuration for DC power supply cabling under 50 feet long. If cabling of 50 feet or longer is required, the additional length may be gained by adding an AC power supply cable (see Examples B & C).

Correct AWG wire size is determined by the current requirement plus cable length. Please see the MDrive Supply Cable AWG Table at the end of this Appendix.

Example A – Cabling Under 50 Feet, DC Power

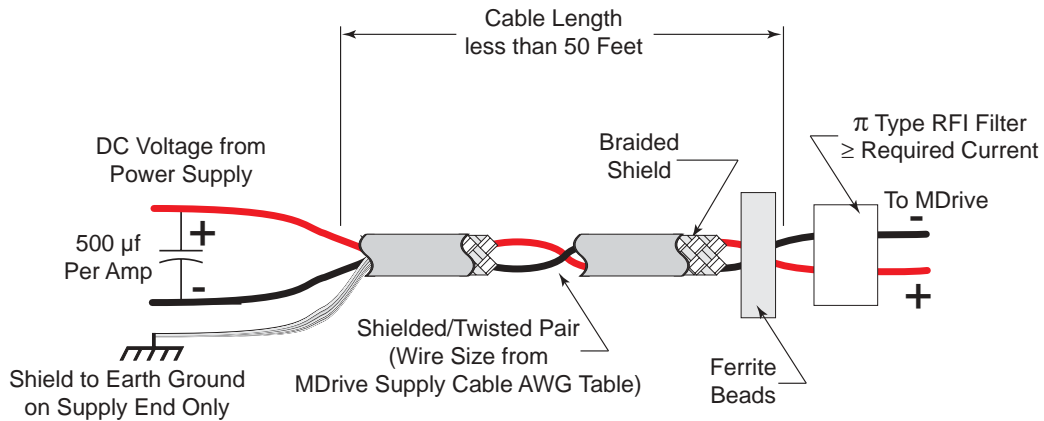

Example B – Cabling 50 Feet or Greater, AC Power to Full Wave Bridge

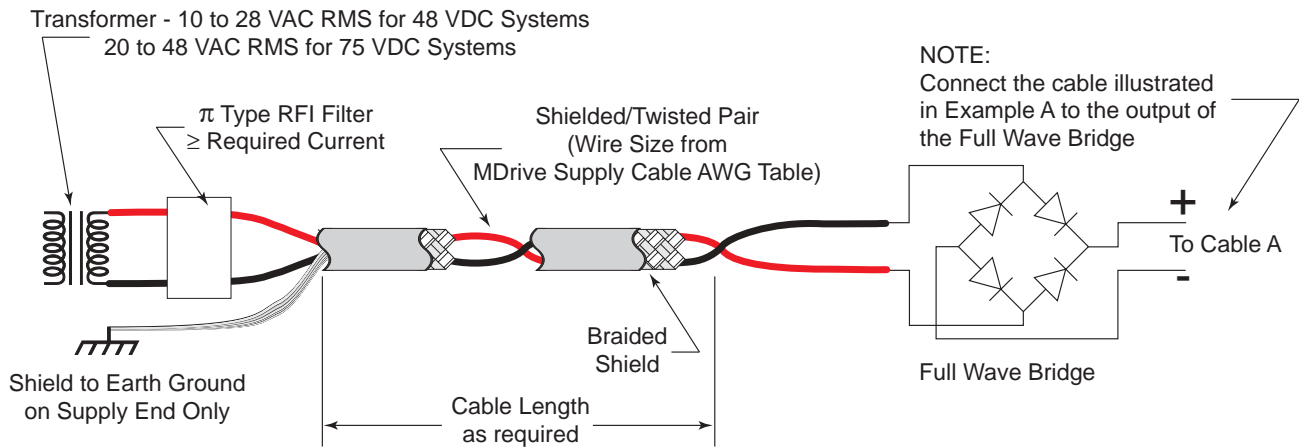

Example C – Cabling 50 Feet or Greater, AC Power to Power Supply

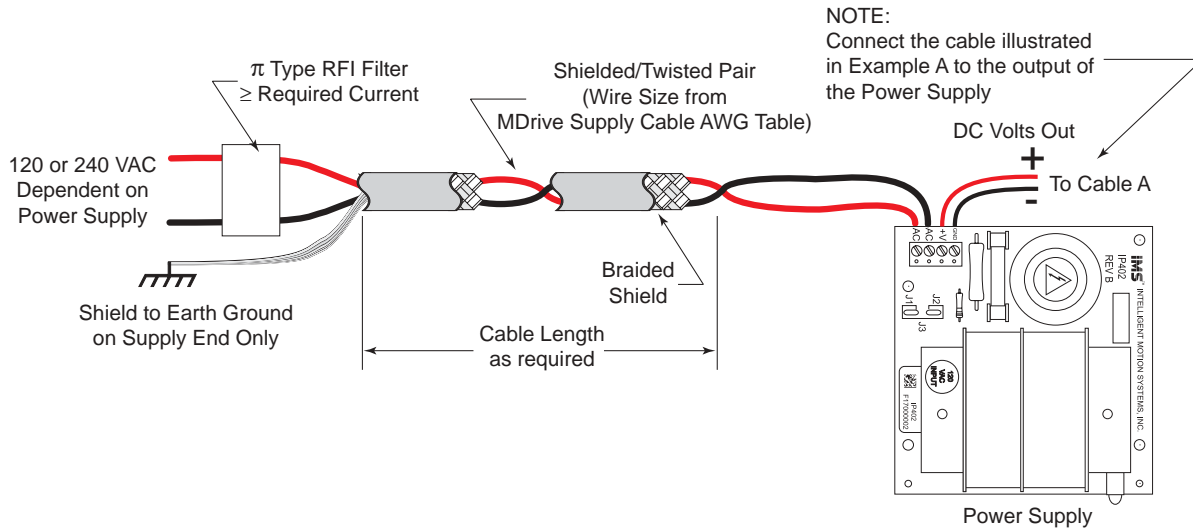

N NOTE: These recommendations will provide optimal protection against EMI and RFI. The actual cable type, wire gauge, shield type and filtering devices used are dependent on the customer’s application and system.

MDrive Supply Cable AWG Table					
1 Ampere (Peak)					
Length (Feet)	10	25	50*	75*	100*
Minimum AWG	20	20	18	18	16
2 Amperes (Peak)					
Length (Feet)	10	25	50*	75*	100*
Minimum AWG	20	18	16	14	14
3 Amperes (Peak)					
Length (Feet)	10	25	50*	75*	100*
Minimum AWG	18	16	14	12	12
4 Amperes (Peak)					
Length (Feet)	10	25	50*	75*	100*
Minimum AWG	18	16	14	12	12
* Use the alternative methods illustrated in Examples A and B when the cable length is ≥ 50 feet. Also, use the same current rating when the alternate AC power is used.					

MDrive Wire Size

N NOTE: Always use Shielded/Twisted Pairs for the MDrive DC Supply Cable and the AC Supply Cable.

WARRANTY

TWENTY-FOUR (24) MONTH LIMITED WARRANTY

Intelligent Motion Systems, Inc. ("IMS"), warrants only to the purchaser of the Product from IMS (the "Customer") that the product purchased from IMS (the "Product") will be free from defects in materials and workmanship under the normal use and service for which the Product was designed for a period of 24 months from the date of purchase of the Product by the Customer. Customer's exclusive remedy under this Limited Warranty shall be the repair or replacement, at Company's sole option, of the Product, or any part of the Product, determined by IMS to be defective. In order to exercise its warranty rights, Customer must notify Company in accordance with the instructions described under the heading "Obtaining Warranty Service."

NOTE: MDrive Motion Control electronics are not removable from the motor in the field.
The entire unit must be returned to the factory for repair.

This Limited Warranty does not extend to any Product damaged by reason of alteration, accident, abuse, neglect or misuse or improper or inadequate handling; improper or inadequate wiring utilized or installed in connection with the Product; installation, operation or use of the Product not made in strict accordance with the specifications and written instructions provided by IMS; use of the Product for any purpose other than those for which it was designed; ordinary wear and tear; disasters or Acts of God; unauthorized attachments, alterations or modifications to the Product; the misuse or failure of any item or equipment connected to the Product not supplied by IMS; improper maintenance or repair of the Product; or any other reason or event not caused by IMS.

IMS HEREBY DISCLAIMS ALL OTHER WARRANTIES, WHETHER WRITTEN OR ORAL, EXPRESS OR IMPLIED BY LAW OR OTHERWISE, INCLUDING WITHOUT LIMITATION, **ANY WARRANTIES OF MERCHANTABILITY OR FITNESS FOR ANY PARTICULAR PURPOSE**. CUSTOMER'S SOLE REMEDY FOR ANY DEFECTIVE PRODUCT WILL BE AS STATED ABOVE, AND IN NO EVENT WILL THE IMS BE LIABLE FOR INCIDENTAL, CONSEQUENTIAL, SPECIAL OR INDIRECT DAMAGES IN CONNECTION WITH THE PRODUCT.

This Limited Warranty shall be void if the Customer fails to comply with all of the terms set forth in this Limited Warranty. This Limited Warranty is the sole warranty offered by IMS with respect to the Product. IMS does not assume any other liability in connection with the sale of the Product. No representative of IMS is authorized to extend this Limited Warranty or to change it in any manner whatsoever. No warranty applies to any party other than the original Customer.

IMS and its directors, officers, employees, subsidiaries and affiliates shall not be liable for any damages arising from any loss of equipment, loss or distortion of data, loss of time, loss or destruction of software or other property, loss of production or profits, overhead costs, claims of third parties, labor or materials, penalties or liquidated damages or punitive damages, whatsoever, whether based upon breach of warranty, breach of contract, negligence, strict liability or any other legal theory, or other losses or expenses incurred by the Customer or any third party.

OBTAINING WARRANTY SERVICE

Warranty service may be obtained by a distributor, if the Product was purchased from IMS by a distributor, or by the Customer directly from IMS, if the Product was purchased directly from IMS. Prior to returning the Product for service, a Returned Material Authorization (RMA) number must be obtained. Complete the form at <http://www.imshome.com/rma.html> after which an RMA Authorization Form with RMA number will then be faxed to you. Any questions, contact IMS Customer Service (860) 295-6102.

Include a copy of the RMA Authorization Form, contact name and address, and any additional notes regarding the Product failure with shipment. Return Product in its original packaging, or packaged so it is protected against electrostatic discharge or physical damage in transit. The RMA number **MUST** appear on the box or packing slip. Send Product to: Intelligent Motion Systems, Inc., 370 N. Main Street, Marlborough, CT 06447.

Customer shall prepay shipping charges for Products returned to IMS for warranty service and IMS shall pay for return of Products to Customer by ground transportation. However, Customer shall pay all shipping charges, duties and taxes for Products returned to IMS from outside the United States.

Part#: MAN-MDRIVE-I

REV05182004



P.O. Box 457, 370 N. Main Street
Marlborough, CT 06447 U.S.A.

Phone: 860/295-6102
Fax: 860/295-6107
Email: info@imshome.com
Home Page: www.imshome.com

TECHNICAL SUPPORT
Eastern U.S.
Phone: 860/295-6102
Fax: 860/295-6107
E-mail: etech@imshome.com
Western U.S.
Phone: 760/966-3162
Fax: 760/966-3165
E-mail: wtech@imshome.com

IMS MOTORS DIVISION
105 Copperwood Way, Suite H
Oceanside, CA 92054
Phone: 760/966-3162
Fax: 760/966-3165
E-mail: motors@imshome.com

IMS EUROPE GmbH
Hahnstrasse 10, VS-Schwenningen
Germany D-78054
Phone: +49/7720/94138-0
Fax: +49/7720/94138-2
European Sales Management
4 Quai Des Etroits
69005 Lyon, France
Phone: +33/4 7256 5113
Fax: +33/4 7838 1537
German Sales/Technical Support
Phone: +49/35205/4587-8
Fax: +49/35205/4587-9
Email: hruland@imshome.com