

Series 350

Granville-Phillips® Series 350 UHV Gauge Controller



Instruction Manual

Instruction manual part number 350010

Revision 05 - February 2009

Series 350

Granville-Phillips® Series 350 UHV Gauge Controller

This Instruction Manual is for use with all Granville-Phillips Series 350 Ultra High Vacuum Gauge Controllers.

A list of applicable catalog numbers is provided on the following page.



Customer Service/Support

For customer service, 24 hours per day, 7 days per week, every day of the year including holidays, toll-free within the USA, phone 1-800-367-4887

For customer service within the USA, 8 AM to 5 PM, Mountain Time Zone weekdays, excluding holidays:

- Toll-free phone: 1-800-776-6543
- Phone: 1-303-652-4400
- FAX: 1-303-652-2844
- Email: co-csr@brooks.com
- World Wide Web: www.brooks.com

Instruction Manual

Granville-Phillips® Series 350 UHV Gauge Controller

Catalog numbers for Series 350 Ultra High Vacuum Gauge Controllers

Controller configured for a Series 274 UHV nude Bayard-Alpert gauge, with 1-line display, electron bombardment degas, and remote input/output interface (CE Marked)

Half-rack mount 350501 - # - # #
 Left mount for 19-inch rack 350502 - # - # #
 Center mount for 19-inch rack 350503 - # - # #

Options:

None
 RS-232
 RS-232 or RS-485 switchable with 4 setpoints
 2 setpoint relays for the ionization gauge



Measurement Units:

Torr
 mbar
 pascal

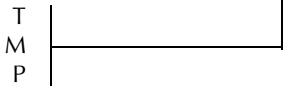

Power cord options:

North American 115 V
 North American 240 V
 Universal Europe 220 V
 United Kingdom 240 V

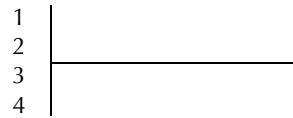

Controller configured for a Series 274 UHV nude Bayard-Alpert gauge and dual Convectron gauge operation, with 3-line display, electron bombardment degas, and remote input/output interface (CE Marked)

Half-rack mount 350507 - # - # #
 Left mount for 19-inch rack 350508 - # - # #
 Center mount for 19-inch rack 350509 - # - # #

Options:

None
 RS-232 or RS-485 switchable with 4 setpoints

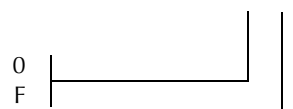

Measurement Units:

Torr
 mbar
 pascal

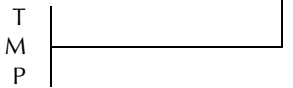

Power cord options:

North American 115 V
 North American 240 V
 Universal Europe 220 V
 United Kingdom 240 V

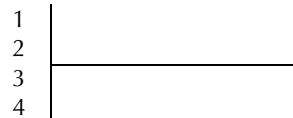

Contents

Chapter 1	Before You Begin	9
	1.1 About These Instructions	9
	1.2 Caution and Warning Statements	9
	1.3 Read and Follow These Instructions	10
	1.4 Customer Service	11
	1.5 Returning a Product for Service	12
Chapter 2	350 Gauge Controller	13
	2.1 General Description	13
	Available Options	13
	IG Cables	13
	Mounting Options	14
	2.2 Installation	14
	Line Voltage Selection	14
	Mounting Configurations	17
	EMC Compliance	19
	Ionization Gauge Types and Installation	19
	Cable Installation	20
	2.3 Wiring	23
	System Ground Test Procedure	24
	2.4 Controls and Indicators	26
	Units of Measure [1]	27
	Power On/Off [4]	27
	Ion Gauge On/Off [2]	27
	Degas On/Off [3]	27
	Remote Input/Output [5]	27
	2.5 Ionization Gauge Theory of Operation	28
	350 UHV Gauge Controller Specifications	30
Chapter 3	Electrometer Module	33
	3.1 Introduction	33
	3.2 Units of Measure	33
	3.3 Display Update Rate Switch [8]	34
	3.4 Degas Timer Override [6]	34
	3.5 Calibration Switch [9]	34
	3.6 Emission Range Switch [10]	35
	3.7 Emission Adjustment [11]	35
	3.8 Sensitivity Adjustment [12]	36
	3.9 Relative Gas Sensitivities	36
	3.10 Analog Output	37
	3.11 Electrometer Calibration	39
	Electrometer Span Adjustment [13]	39
	Overpressure Shutdown Adjustment [14]	39
	A/D calibration [15]	39

Chapter 4	Process Control Module	41
4.1	Introduction	41
4.2	Process Control System Connections	41
4.3	To Display a Setpoint	41
4.4	To Modify a Setpoint	42
4.5	Relay Polarity Setting	42
4.6	Relay Disable	43
4.7	Pin Assignments	44
4.8	Process Control Operation	44
	Setpoint Display and Adjustment	44
	Manual Override [16]	45
4.9	Process Control Theory of Operation	45
	Process Control Specifications	45
Chapter 5	RS-232 Module	47
5.1	Introduction	47
5.2	RS-232 Interface	47
	Selecting the Byte Format	47
	Baud Rate	47
	Character Framing	47
	Talk-Only Mode	48
	Handshake Line Control Switches	48
	Invert RTS Switch	48
5.3	Operation	49
	Command Syntax	49
	DG	49
	DGS	50
	DS IG	50
	IG1	50
	IG2	50
	Error Messages	51
5.4	RS-232 Theory of Operation	51
	Handshaking	51
	CTS, DSR	52
	DCD	52
	DTR	52
	RTS	52
5.5	Reversing the Polarity of RTS	52
5.6	RS-232 Troubleshooting	52
	RS-232 Specifications	53
Chapter 6	Digital Interface Module	55
6.1	Process Control Installation	55
6.2	Process Control System Connections	55
6.3	To Display a Setpoint	56

6.4	To Modify a Setpoint	56
6.5	Process Control Connector	57
6.6	Process Control Display Assignment	57
6.7	Manual Override	58
6.8	RS-232/RS-485 Installation	58
6.9	Setpoint Display and Adjustment	60
6.10	Switch Settings	61
6.11	RS-232 Connectors	64
6.12	RS-485 Connector	65
6.13	Operation	65
	RS-232/RS-485 Command Syntax	66
	DG	66
	DGS	66
	IGB	67
	RD	67
	F1	67
	F2	67
	PC	67
	Error Messages	69
	RS-232/RS-485 Signals	69
	RS-232 and RS-485 Start Characters	70
6.14	Troubleshooting	71
	Host Computer Interface Specifications	72

Chapter 7

	Convectron Gauge Module	73
7.1	Introduction	73
7.2	Safety Instructions	75
7.3	Installation Considerations	77
7.4	Orientation	77
7.5	Mounting	78
	Compression Mount	79
	1/8 NPT Mount	79
	NW Flange	79
7.6	Reading Pressure	80
	Operation Below 10^{-3} Torr	80
	Use with Gases Other Than N ₂ or Air	80
	Indicated Versus True Pressure	81
7.7	Unit of Measure [16 and 17]	86
7.8	Display Update Rate Switch [18]	86
7.9	Analog Output [20 and 21]	87
7.10	Calibration	88
	Analog Output Full Scale Adjustment [27]	88
7.11	Analog Output Offset for Gauges A and B [28 and 29]	89
	Zero Adjustment [23 and 26]	90
	Atmosphere Adjustment [22 and 25]	90

Chapter 1 Before You Begin

1.1 About These Instructions

These instructions explain how to install, operate, and maintain the Granville-Phillips® Series 350 UHV gauge controller.

This chapter explains caution and warning statements, which must be adhered to at all times; explains your responsibility for reading and following all instructions; defines the terms that are used throughout this instruction manual; and explains how to contact customer service.

1.2 Caution and Warning Statements

This manual contains caution and warning statements with which you *must* comply to prevent inaccurate measurement, property damage, or personal injury.



CAUTION

Caution statements alert you to hazards or unsafe practices that could result in inaccurate measurement, minor personal injury or property damage.

Each caution statement explains what you must do to prevent or avoid the potential result of the specified hazard or unsafe practice.



WARNING

Warning statements alert you to hazards or unsafe practices that could result in severe property damage or personal injury due to electrical shock, fire, or explosion.

Each warning statement explains what you must do to prevent or avoid the potential result of the specified hazard or unsafe practice.

Caution and warning statements comply with American Institute of Standards Z535.1-2002 through Z535.5-2002, which set forth voluntary practices regarding the content and appearance of safety signs, symbols, and labels.

Each caution or warning statement explains:

- a. The specific hazard that you *must* prevent or unsafe practice that you *must* avoid,
- b. The potential result of your failure to prevent the specified hazard or avoid the unsafe practice, and
- c. What you *must* do to prevent the specified hazardous result.

1.3 Read and Follow These Instructions

You must comply with all instructions while you are installing, operating, or maintaining the Series 350 UHV controller or vacuum gauges. Failure to comply with the instructions violates standards of design, manufacture, and intended use of the controller. Granville-Phillips and Brooks Automation disclaim all liability for the customer's failure to comply with the instructions.

- *Read instructions* – Read all instructions before installing or operating the product.
- *Follow instructions* – Follow all installation, operating and maintenance instructions.
- *Retain instructions* – Retain the instructions for future reference.
- *Heed warnings and cautions* – Adhere to all warnings and caution statements on the product and in these instructions.
- *Parts and accessories* – Install only those replacement parts and accessories that are recommended by Granville-Phillips. Substitution of parts is hazardous.

 **WARNING**

Read these safety notices and warnings before installing, using, or servicing this equipment. If you have any doubts regarding the safe use of this equipment, contact the Granville-Phillips Customer Service department at the address listed in this user manual.

Danger - High Voltage

180 Vdc is present on the Series 350 Controller on the cable and the ionization gauge when the gauge is turned on. Voltages as high as 700 Vdc peak are present during degas.

System Grounding

Grounding, though simple, is very important! Be certain that ground circuits are correctly used on your ion gauge power supplies, gauges, and vacuum chambers, regardless of their manufacturer. Safe operation of vacuum equipment, including the Series 350 High Vacuum Gauge Controller, requires grounding of all exposed conductors of the gauges, the controller and the vacuum system. **LETHAL VOLTAGES** may be established under some operating conditions unless correct grounding is provided.

Ion producing equipment, such as ionization gauges, mass spectrometers, sputtering systems, etc., from many manufacturers may, under some conditions, provide sufficient electrical conduction via a plasma to couple a high voltage electrode potential to the vacuum chamber. If exposed conductive parts of the gauge, controller, and chamber are not properly grounded, they may attain a potential near that of the high voltage electrode during this coupling. Potential fatal electrical shock could then occur because of the high voltage between these exposed conductors and ground.

Explosive Gases

Do not use Series 350 instruments to measure the pressure of explosive or combustible gases or gas mixtures. Ionization gauge filaments operate at high temperatures.

Implosion / Explosion

Glass ionization gauges, if roughly handled, may implode under vacuum causing flying glass which may injure personnel. If pressurized above atmospheric pressure, glass tubes may explode. A substantial shield should be placed around vacuum glassware to prevent injury to personnel.

Danger of injury to personnel and damage to equipment exists on all vacuum systems that incorporate gas sources or involve processes capable of pressuring the system above the limits it can safely withstand.

For example, danger of explosion in a vacuum system exists during backfilling from pressurized gas cylinders because many vacuum devices such as ionization gauge tubes, glass windows, glass belljars, etc., are not designed to be pressurized.

Do not attach cables to glass gauge pins while the gauge is under vacuum. Accidental bending of the pins may cause the glass to break and implode. Cables, once installed, should be secured to the system to provide strain relief for the gauge tube pins.

Install suitable devices that will limit the pressure from external gas sources to the level that the vacuum system can safely withstand. In addition, install suitable pressure relief valves or rupture disks that will release pressure at a level considerably below that pressure which the system can safely withstand.

Suppliers of pressure relief valves and pressure relief disks are listed in Thomas Register under "Valves, Relief", and "Discs, Rupture".

Confirm that these safety devices are properly installed before installing the Series 350 Vacuum Gauge Controller (VGC). In addition, check that (1) the proper gas cylinders are installed, (2) gas cylinder valve positions are correct on manual systems, and (3) the automation is correct on automated systems.

Operation

It is the installer's responsibility to ensure that the automatic signals provided by the process control module are always used in a safe manner.

Carefully check manual operation of the system and the setpoint programming before switching to automatic operation. Where an equipment malfunction could cause a hazardous situation, always provide for fail-safe operation. As an example, in an automatic backfill operation where a malfunction might cause high internal pressures, provide an appropriate pressure relief device.

1.4 Customer Service

For customer service:

- Phone **1-303-652-4400** or **1-800-776-6543**, 8 AM to 5 PM Mountain

Time Zone, excluding weekends within the USA.

- Phone **1-800-367-4887** 24 hours per day, 7 days per week within the USA.
- Email *co-csr@brooks.com*
- For Global Customer Support, go to www.brooks.com, click on Contact Us, then click on Global Offices to locate the Brooks Automation office nearest you.

1.5 Returning a Product for Service

If the Series 350 UHV Gauge Controller must be returned to the factory for service, request a Return Authorization (RA) from Brooks Automation / Granville-Phillips. Do not return products without first obtaining an RA. In some cases a hazardous materials document may be required. The Brooks Automation / Granville-Phillips Customer Service Representative will advise you if the hazardous materials document is required.

When returning equipment to Brooks Automation / Granville-Phillips, be sure to package the products to prevent shipping damage. Circuit boards and modules separated from the controller chassis must be handled using proper anti-static protection methods and must be packaged in anti-static packaging. Brooks Automation / Granville-Phillips will supply return packaging materials at no charge upon request. Shipping damage on returned products as a result of inadequate packaging is the Buyer's responsibility.

Chapter 2 350 Gauge Controller

2.1 General Description

The Series 350 ionization gauge controller measures pressures from less than 1×10^{-11} Torr (1.3×10^{-11} mbar or 1.3×10^{-9} pascal) to 1×10^{-3} Torr, air equivalent, depending on transducer and emission current used. It is primarily intended for use with a nude version of a Bayard-Alpert ionization gauge. Electron bombardment degas is standard with an interlock which only allows usage when displayed pressure is below 5×10^{-5} Torr. A built-in timer turns off the degas function after 15 minutes of operation if not previously done manually. Degas power is fixed at approximately 40 watts.

Two filament switching is standard which allows front panel control of a dual filament style B-A gauge.

Pressure readout is via a front panel digital display and analog output.

Remote I/O provides an IG status output, remote gauge on/off for each filament and remote degas on/off functions.

The controller is a modular instrument with infrequently used controls housed behind a hinged front panel, thus reducing front panel clutter and allowing the controller to reside in a half-rack space.

Available Options

350002

Two channel process control module provides 2 single pole, double throw relays. Digital setpoints have front panel LED indicators and manual override switches.

350003

RS-232 computer interface module provides readout of pressure, process control relay status, and ion gauge control.

350027

PC/RS-232/RS-485 module provides four single-pole, double-throw relays configurable to ion gauge or Convectron gauges. Digital setpoints have front panel LED indications and manual override switches.

350037

Six-channel process control module provides four single-pole, double-throw relays. Configurable to ion gauge or Convectron gauges. Digital setpoints have front panel LED indications and manual override switches.

350054

Convectron gauge module provides readout of pressure from two Convectron gauges.

Various custom configurations are available where more than one option module may be installed. If the Convectron option is used with the Series 350 gauge controller, only Series 275 convectron gauge tubes manufactured in June of 1997 or later can be used on the units bearing the CE mark. Each gauge tube is marked with a date code. This date code must be F7 (June 1997) or after.

IG Cables

The controller is capable of operating an ion gauge located up to 100 feet away from the controller by using standard cables. Cables are available for

use with nude B-A gauges using individual slip-on pin connectors for the two filaments, filament common, grid and collector.

Mounting Options

The controller can be ordered in half rack (standard), bench, full rack, or two units in a full rack.

2.2 Installation

Line Voltage Selection

The controller is supplied with a convenient IEC 320 AC main connection receptacle, which allows selection of a detachable line cord to match your available AC main power.

Table 2-1 Line Voltage Selector Settings

Nominal Line	Selector Card	Fuse F2
Voltage $\pm 10\%$	Setting	Type
100 VAC	100	1.25A SB Time Lag (T) ⁽¹⁾
120 VAC	120	1.25A SB Time Lag (T) ⁽¹⁾
220 VAC	220	0.60A SB Time Lag (T) ⁽²⁾
240 VAC	240	0.60A SB Time Lag (T) ⁽²⁾

⁽¹⁾ Fuse is Littelfuse 3131.25 (GP P/N 004966).

⁽²⁾ For North American fusing, fuse is Littelfuse 313.600 (GP P/N 009645); for European fusing, fuses are Littelfuse 218.630 (GP P/N 011681).

Replacement fuses are available from Brooks Automation, Inc. / Granville-Phillips.

Figure 2-1 Line Voltage Selector Card

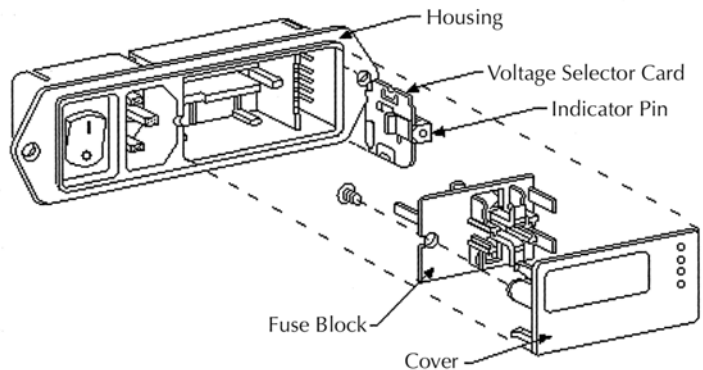

Verify that the line voltage selector indicator displays the line voltage value of the available local AC line voltage. If the indicator does not display the correct line voltage value as listed in Table 2-1, perform the following procedure, referring to Figure 2-2.

! WARNING

Operation of the controller with the line voltage selector card improperly set can cause property damage or personal injury.

Before putting the controller into operation, make sure the line voltage selector card is properly set.

Figure 2-2 Line Voltage Selector

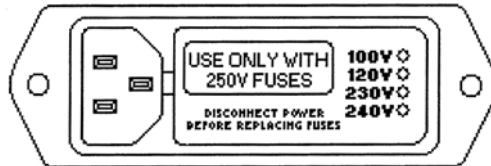

To change from North American to European fusing:

1. Use a small-blade screwdriver or similar tool to open the cover.
2. Loosen the Phillips-head screw two turns.
3. Remove the fuse block by sliding it up, then away from the Phillips-head screw and lifting the fuse block upward from the pedestal.
4. Change the fuses:
 - Two European fuses are required, although you may use a dummy fuse in the neutral (lower) holder.
 - The fuses that go into the housing first are the active fuses.
5. Invert the fuse block and slide it back onto the Phillips-head screw and pedestal.
6. Tighten the Phillips-head screw.
7. Replace the cover.

Figure 2-3 Fuse Changing Procedure

European Fusing Arrangement

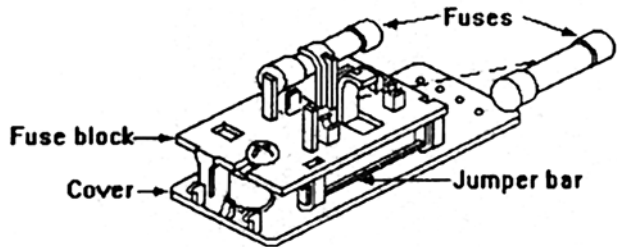

North American Fusing Arrangement

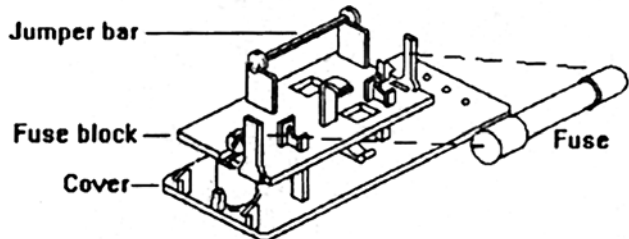

Fuse Block/Cover Assembly

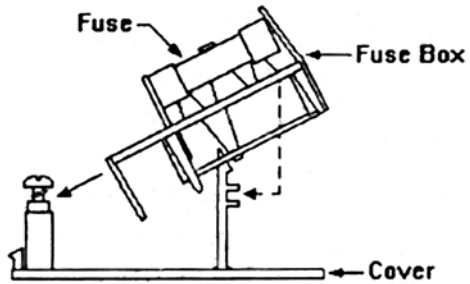

To change the selected voltage, refer to Figure 2-4 and follow these steps:

1. Use a small-blade screwdriver or similar tool to open the cover.
2. Set aside the cover/fuse block assembly.
3. Pull the voltage selector card straight outward from the housing.
4. Using the indicator pin, orient the selector card so that the desired voltage is at the bottom.

When the indicator pin is fixed, you may select successive voltages by rotating the card 90° clockwise.

5. With the printed side of the voltage selector card facing the IEC connector, insert the card into the housing so that the side showing the selected voltage goes into the housing first.
6. Replace the cover.
7. Verify that the indicator pin indicates the selected voltage.

Figure 2-4 Voltage Selector Card Orientation

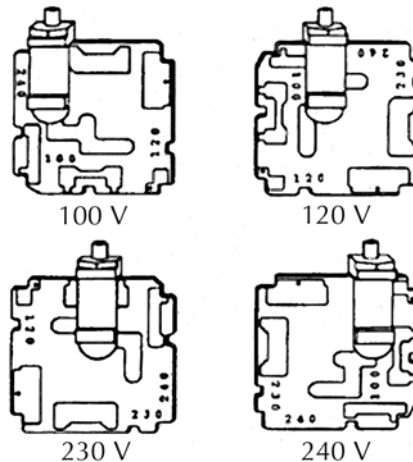

Mounting Configurations

Figure 2-5 illustrates the various configurations available for mounting the controller.

Note that the controller should be mounted in a location with free air flow and ambient temperature less than 40 °C (104 °F).

Figure 2-5 Mounting Configurations

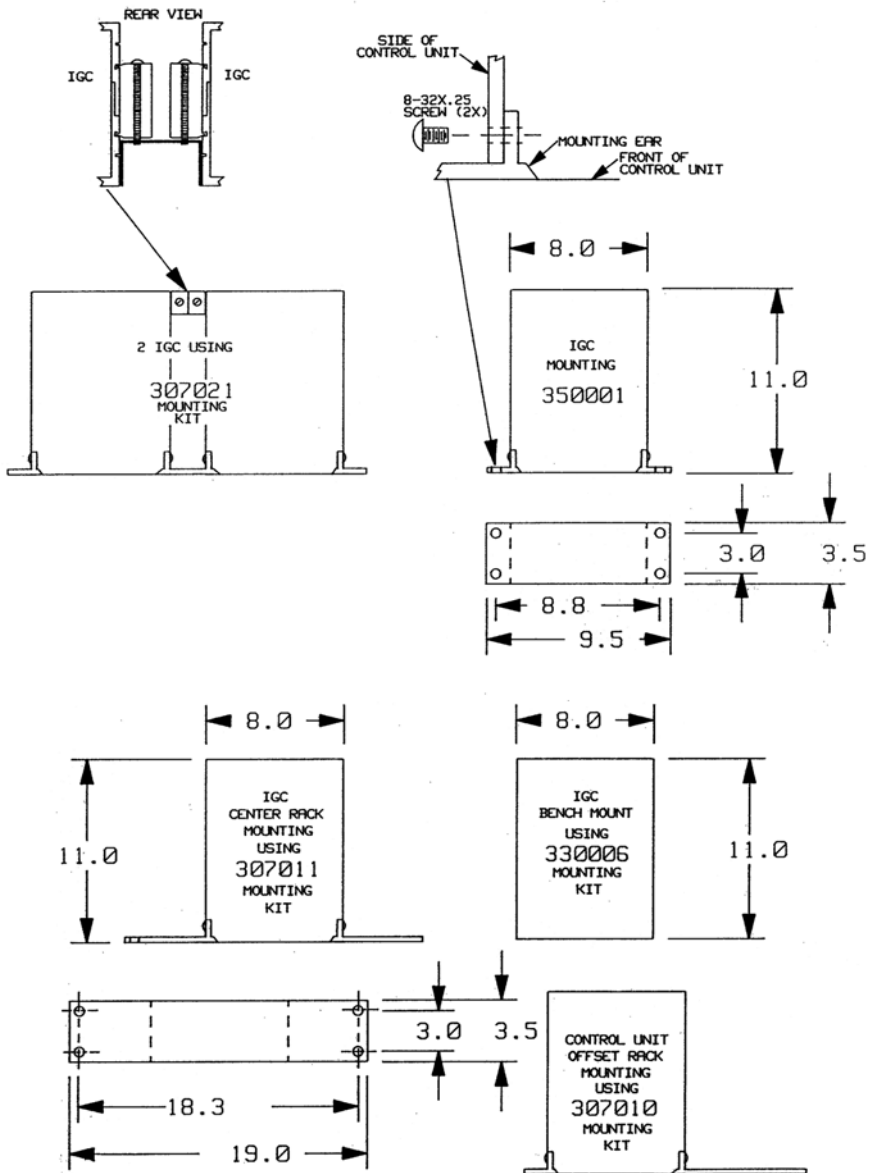

EMC Compliance

To comply with the standards for immunity as called for by the EMC Directive, careful consideration to grounding and shielding of instrumentation cables is required. User supplied cables must have the drain shield of the cable connected to chassis ground. Immunity to radiated and conducted RF energy in industrial environments will depend on cable construction and routing. The VGC system will perform within the typical uncertainty of a Bayard-Alpert ion gauge system when subjected to industrial levels of RF energy.

Snap-on ferrite sleeves (Granville-Phillips part number 013746, 2 ea. provided) must be installed on the ion gauge cable at both the gauge tube end and controller end of the cable. Failure to install these ferrite suppression cores may result in non-compliance with the EU EMC Standards for Industrial Level Immunity.

Ionization Gauge Types and Installation



WARNING

Attaching cables to glass gauge pins while the gauge is under vacuum can cause the glass to break or implode, resulting in property damage or personal injury.

- Do not attach cables to glass gauge pins while the gauge is under vacuum.
- Secure cables to the system to provide strain relief for gauge tube pins.

The controller is designed to operate a Bayard-Alpert type or equivalent ionization gauge with either single or dual filaments and nude style construction. It is ideally suited for a nude gauge such as the Granville-Phillips series 274022 or 274023, which have an x-ray limit in the low 10^{-11} Torr (10^{-11} mbar, 10^{-9} pascal) range. If the controller is placed near the pump, the pressure in the gauge may be considerably lower than in the rest of the system. If placed near a gas inlet or source of contamination, the pressure in the gauge may be higher.

If an unshielded gauge is placed near an electron beam evaporation source or used in a sputtering system, spurious electrons or ions may disturb the measurement. Screens or other shielding should be placed between the gauge and the system if spurious charged particles or severe electromagnetic interference is present.

Figure 2-6 illustrates typical nude gauge base configurations used with the standard connector cable.

Figure 2-6 Standard Nude Gauge Base Configuration

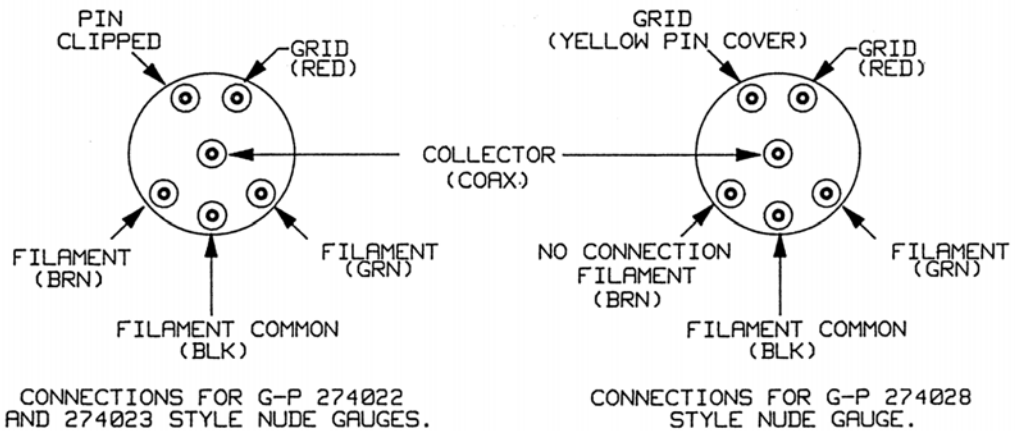

- Front panel switch 1 controls green filament lead.
- Front panel switch 2 controls brown filament lead.

Cable Installation

It is intended that all wiring either to or from the controller, whether supplied by Granville-Phillips Company or not, be installed in accordance with the safety requirements of NEC/NFPA 70. Cables provided by Brooks Automation, Inc./Granville-Phillips for connection to sensors or transducers is, at a minimum, designed for use as Appliance Wiring Material (UL category AVL2), and is constructed of appropriate material and dimensions for the voltages and currents provided by the controller. Install cables to/from the controller in accordance with the applicable local, state and national safety requirements.

Raceway and/or conduit may be needed for certain installations.

⚠ WARNING

Improper grounding could cause product failure, property damage, or serious personal injury.

To reduce the risk of product failure, property damage, or serious personal injury, follow ground network requirements for the facility.

- Maintain all exposed conductors at earth ground.
- Properly ground all power supplies, gauges, and vacuum chambers.
- Ground the controller as instructed below.

Figure 2-7 Cable connections to glass ion gauge

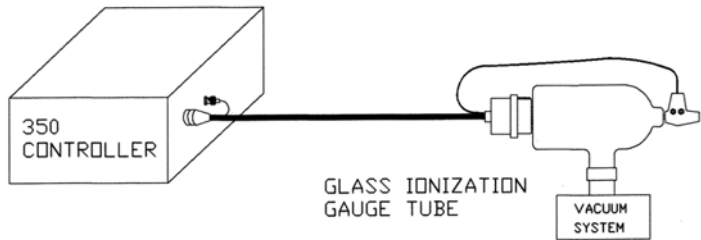

Figure 2-8 Cable Connections to Granville-Phillips 274041, 274042, or 274043 Gauge

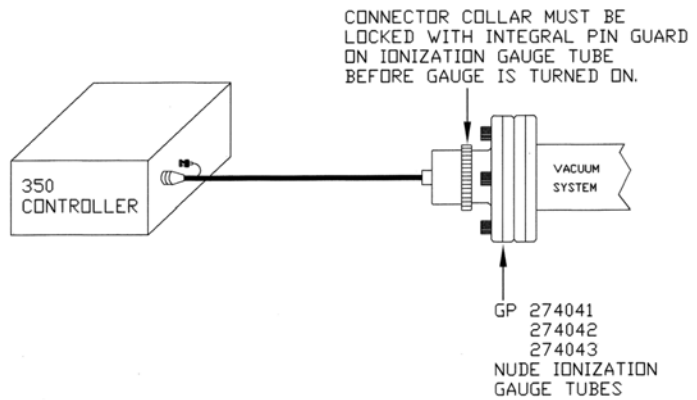

Figure 2-9 Cable Connections to Granville-Phillips 274053, 274057, or 274058 Gauge

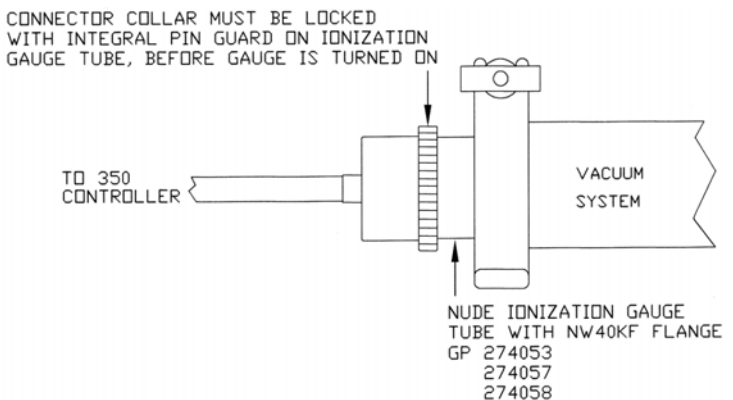
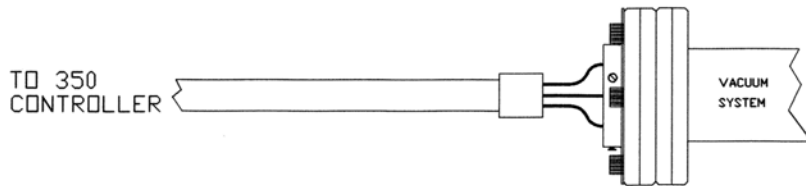
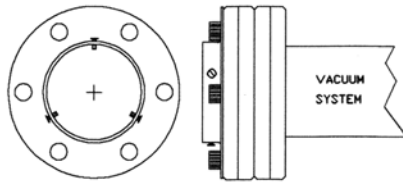

Figure 2-10 Installation to Nude Ion Gauge with ConFlat® Fitting and Without Integral Pin Guard

A COVER ASSEMBLY GP #271025 MUST BE ORDERED SEPARATELY FROM GRANVILLE-PHILLIPS.

WHEN INSTALLING THE TUBE ON THE VACUUM SYSTEM INSTALL THE COLLAR FROM THE 271025 KIT.

INSTALL THE SHROUD OVER THE CABLE AND CONNECT THE IG CABLE TO THE INDIVIDUAL PINS OF THE NUDE IG



NEXT, INSTALL THE SHROUD (FROM THE G-P 271025 KIT)

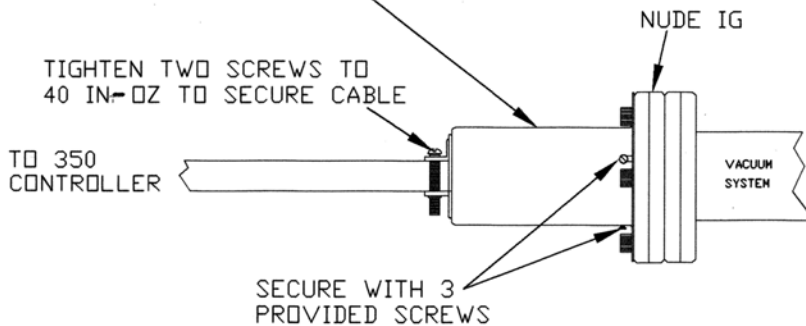

NOTE: Cable and nude ionization gauge combinations other than those illustrated above, and which leave ionization gauge pins exposed with no locking connector or protective shroud, are not considered as complying with UL3101-1, EN61010-1, or CAN/CSA-C22.2 No. 1010.1-92.

2.3 Wiring

Figure 2-11 illustrates short-cable connections, up to 50 feet (15 meters), to the nude ionization gauge.

Figure 2-12 illustrates short-cable connections, 50 to 100 feet (15 to 30 meters), to the nude ionization gauge.

Figure 2-11 Nude Ionization Gauge Cable, Maximum 50 feet (15 meters)

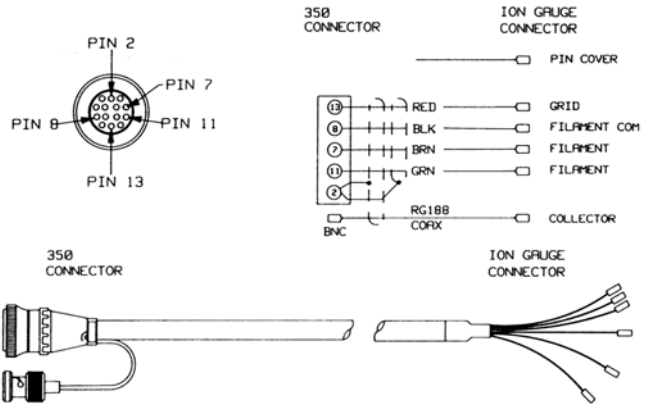
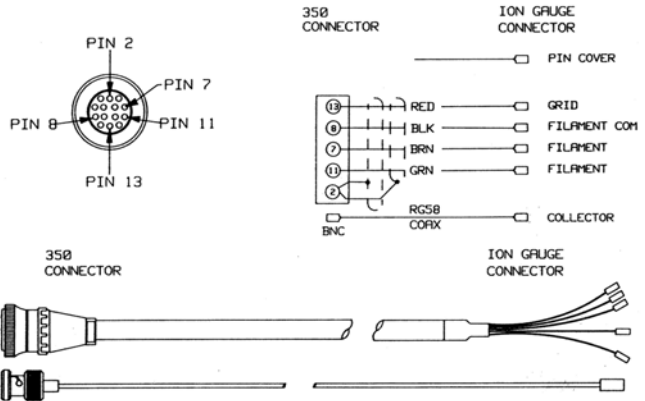

Figure 2-12 Nude Ionization Gauge Cable Set, Maximum 100 feet (30 meters)



System Ground Test Procedure

Physically examine the grounding of both the controller and the vacuum chamber. Make sure there is a heavy duty ground connection to all exposed conductors on the vacuum chamber. Note that a horizontal “O” ring or “L” ring gasket, without metal clamps, can leave the chamber above it electrically isolated. Power can be delivered to mechanical and diffusion pumps without any ground connections to the system frame or chamber. Water line grounds can be lost by a plastic or rubber tube interconnection. What was once a carefully grounded vacuum system can, by innocent failure to reconnect all ground connections, become a very dangerous device. Use the following procedure to test each of your vacuum systems which incorporates an ionization gauge.

This procedure uses a conventional volt-ohm meter (VOM) and resistor (10 Ω , 10 W).

1. With the gauge controller turned off, test for both DC and AC voltages between the metal parts of the vacuum chamber and the power supply chassis.
2. If no voltages exist, measure resistance. The resistance should not exceed 2 ohms. Two ohms, or less, implies commonality of these grounds that should prevent the plasma from creating a dangerous voltage between them. This test does not prove that either connection is earth ground, only that they are the same. If more than 2 ohms is indicated, check with your electrician.
3. If DC and AC voltages exist and are less than 10 volts, shunt the meter with a 10 Ω , 10 W resistor. Repeat the voltage measurement. With the shunt in place across the meter, if the voltage remains at 83% or more of the unshunted value, commonality of the ground is implied.

$$\frac{\text{Voltage}_{\text{Shunted}}}{\text{Voltage}_{\text{Unshunted}}} = 0.83 \text{ or more}$$

Repeat the measurements several times to be sure that the voltage ratio is not changing with time. A ratio of 15.083 or more should prevent the plasma from creating a dangerous voltage between these grounds. If more than 10 V exists between grounds, check with your electrician.

4. If the voltage change in step 3 is greater than 17% due to the placement of the shunt, it complicates the measurement. The commonality of the ground may be satisfactory and the coupling poor, or the commonality could be poor. Your electrician should be asked to check the electrical continuity between these two ground systems. The placement of a second ground wire (dashed line in Figure 2-13) between the vacuum chamber and the controller chassis is NOT a safe answer, for large currents could flow through it. Professional help is recommended.

**WARNING**

Improper grounding could cause product failure, property damage, or serious personal injury.

To reduce the risk of product failure, property damage, or serious personal injury, follow ground network requirements for the facility.

- Maintain all exposed conductors at earth ground.
- Properly ground all power supplies, gauges, and vacuum chambers.
- Ground the controller as instructed below.

Figure 2-13 System Grounding

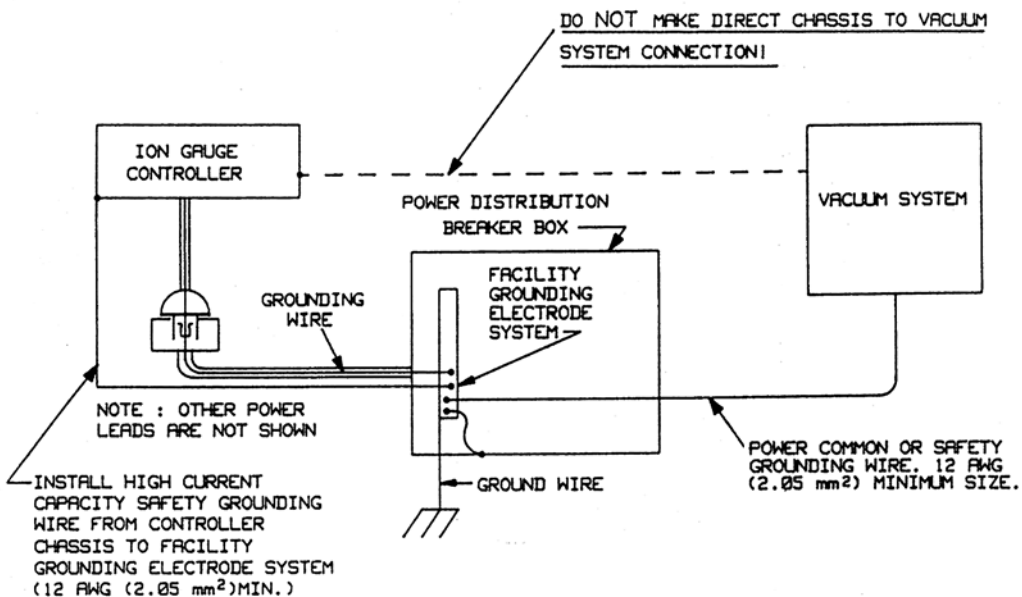

2.4 Controls and Indicators

A description of the control and indicators found on a basic controller is given in this section. For detailed instructions pertaining to particular functions, please consult the chapter for that function.

Figure 2-14 Control Unit Front Panel

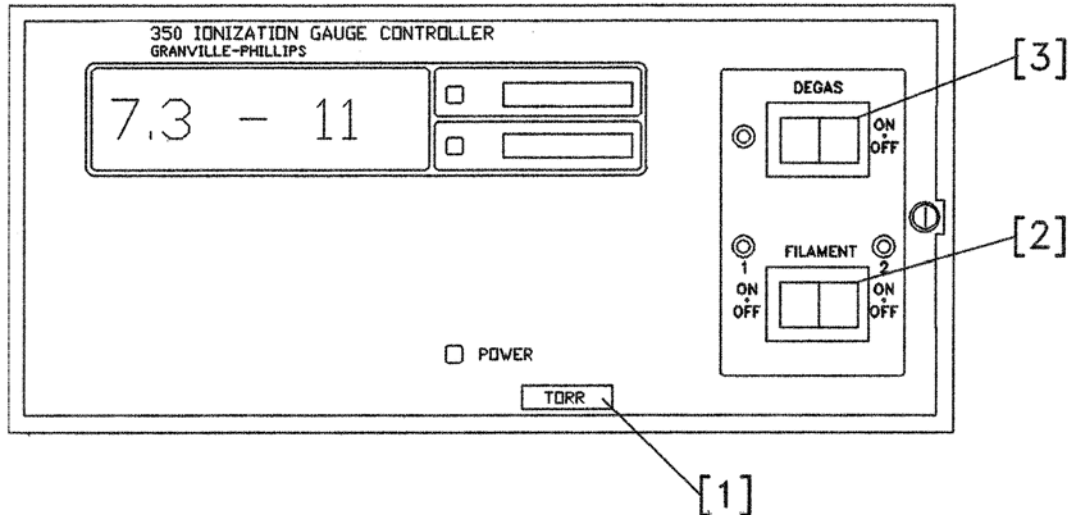
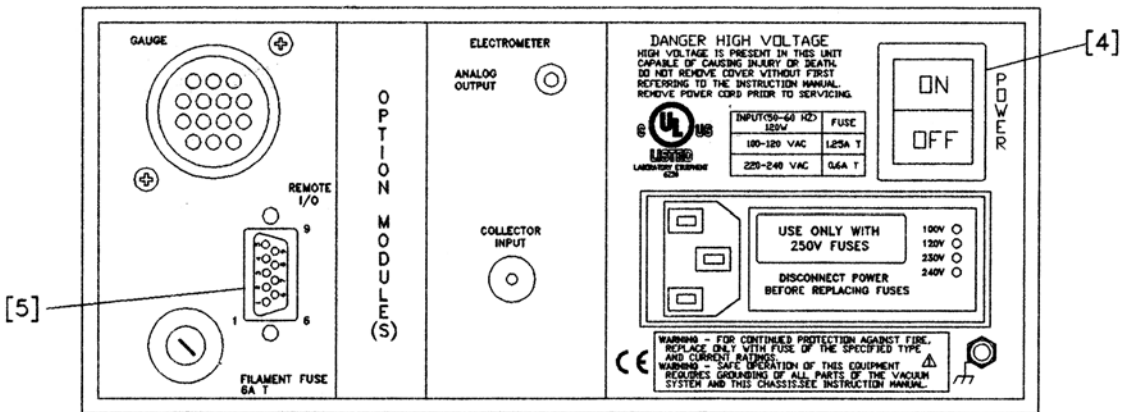

Figure 2-15 Control Unit Rear Panel



- Units of Measure [1]** The unit of measure displayed is selectable via a switch on the Electrometer Module. These units will be indicated on the front panel label when shipped from the factory. See the electrometer chapter for instructions on changing units. The pressure units label [1] can be changed by the user if the system of units is changed. Slide the label out from the top.
- Power On/Off [4]** To turn on the controller, depress the top half of the power switch located on the rear panel. "Power On" indication is by the green LED located adjacent to the word "POWER."
To turn off the controller, depress the lower half of the power switch.
- Ion Gauge On/Off [2]** The ion gauge may be turned on or off by the front panel momentary rocker switch or by remote control using the rear panel I/O connector.
To turn on the ion gauge from the front panel, press the momentary rocker switch [2] either to the left or right to turn on a filament of a dual filament gauge tube. If a single filament gauge tube is used it will be necessary to know which switch position was selected. To turn the gauge off, press the rocker switch again in the same direction. After an approximate 2 second delay the actual pressure will be displayed. The maximum voltage appearing on the gauge tube contacts will be 5.5 Vdc when the ion gauge is off.
- Degas On/Off [3]** The EB degas may be turned on or off by the front panel momentary rocker switch, [3], or the remote control input. To turn degas on, press the degas momentary rocker switch. To turn it off, press again or press the gauge momentary rocker switch to turn off degas and turn on the gauge. There is an internal 15 minute timer which will turn off degas if not previously turned off manually.
Degas ON indication is by the degas LED adjacent to the word "DEGAS" on the front panel. Degas can not be activated unless the gauge has first been turned on and indicated system pressure is below 5×10^{-5} Torr. This prevents degas turn on at pressures where emission can not be established or where degas is of no practical use. Pressure indication is possible during degas but can be unreliable depending upon the condition of the elements. Degas power is approximately 40 W with the grid potential at 530 Vdc.
- Remote Input/Output [5]** Three TTL compatible inputs are provided through the rear panel allowing control of the ion gauge, filament 1 and 2 and degas. The function of the front panel keys must be reproduced by either a contact closure or an asserted low (0 V) logic state on these inputs. This low state must be held continuously for at least 25 milliseconds. After this, the input must be allowed to pull high for at least 105 milliseconds before another low will be accepted. These inputs have passive pull-ups.
An optoisolator is provided to indicate filament status. This has a VCEO of 40 Vdc and a current rating of 200 mA dc.

Table 2-2 Remote Input/Output Pin Functions

Pin Number	Function
1	Gauge Filament 1 On/Off Remote*
2	Ground
3	Not used
4	Filament status optoisolator collector
5	Filament status optoisolator emitter
6	Degas On/Off Remote*
7	Ground
8	Not used
9	Gauge Filament 2 On/Off Remote*

* Active low inputs.

2.5 Ionization Gauge Theory of Operation

The functional parts of a typical ionization gauge are the filament (cathode), grid (anode) and ion collector, shown schematically in Figure 2-16. These electrodes are maintained by the gauge controller at +30, +180, and 0 volts, relative to ground, respectively.

Figure 2-16 Ionization Gauge Schematic

The filament is heated to such a temperature that electrons are emitted, and accelerated toward the grid by the potential difference between the grid and filament. Most of the electrons eventually collide with the grid, but many first traverse the region inside the grid one or more times.

When an energetic electron collides with a gas molecule, an electron may be dislodged from the molecule, leaving it with a positive charge. Most ions are then accelerated to the collector. The rate at which electron collisions with molecules occur is

proportional to the density of gas molecules, and hence the ion current is proportional to the gas density (or pressure, at constant temperature).

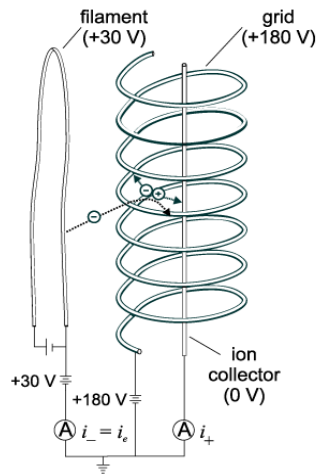

The amount of ion current for a given emission current and pressure depends on the ion gauge design. This gives rise to the definition of ion gauge "sensitivity", frequently denoted by "K":

$$K = \text{ion current} / (\text{e mission current} \times \text{pressure})$$

Nude Bayard-Alpert type gauges typically have sensitivities of 25/Torr when used with nitrogen or atmosphere although this can vary as it is dependent upon the distance of the gauge tube elements to surrounding elements of the vacuum system. Sensitivities for other gases are given in *Relative Gas Sensitivities*, page 36.

The ion gauge controller varies the heating current to the filament to maintain a constant electron emission, and measures the ion current to the collector. The pressure is then calculated from these data.

Ion gauge degas is accomplished by electron bombardment of the grid. During EB degas, the grid potential is raised to 530 Vdc and 40 watts is dissipated.

350 UHV Gauge Controller Specifications

Physical

<i>Width</i>	241 mm (9.5 in.) with 1/2 rack mounting brackets
<i>Height</i>	89 mm (3.5 in.)
<i>Depth</i>	356 mm (14 in.) includes 76 mm (3 in.) for connectors and cables
<i>Weight</i>	4.8 kg (10.5 lbs.)

Electrical

<i>Voltage</i>	90 to 130 VAC or 200 to 260 VAC
<i>Frequency</i>	50 to 60 Hz
<i>Power</i>	120 watts max.
<i>Fuse Ratings</i>	AC Line 100 to 120 V, 1.25 A Time Lag (T), Littelfuse 3131.25 AC Line 200 to 240 V, 0.60 A Time Lag (T), Littelfuse 313.600 +/- 20 V supplies: Granville-Phillips P/N 013132, 1.5 A slow-blow Littelfuse 22901.5

Grid Supply Granville-Phillips P/N 013193, 0.1 A, 500 V, slow-blow
Bussman FNQ-1/10
Gould-Shawmut ATQ 1/10

Filament Supply Granville-Phillips P/N 013192, 6.0 A slow-blow
Bussman MDL-6

Environmental Conditions

<i>Altitude</i>	Indoor use
<i>Temperature</i>	Up to 2000 meters
<i>Maximum relative humidity</i>	0° to 40° C (32° to 104° F) 80% for temperatures up to 31 °C Decreasing linearly to 50% relative humidity at 40° C (104° F)
<i>Transient over voltages</i>	Installation category (over voltage category) II
<i>Pollution degree II</i>	In accordance with IEC 664

Pressure Range Specifications

Emission Range		
.01 mA to 0.1 mA 1 x 10 ⁻⁹ to 1 x 10 ⁻² Torr	0.1 mA to 1 mA 1 x 1 ⁻¹⁰ to 1 x 10 ⁻³ Torr	1 mA to 10 mA 1 x 10 ⁻¹¹ to 1 x 10 ⁻⁴ Torr
Readable to		
1 x 10 ⁻¹⁰ Torr	1 x 10 ⁻¹¹ Torr	1 x 10 ⁻¹² Torr

Internal overpressure limiter is factory adjusted to trip at 1 decade below the upper limits specified above.

Electronic Accuracy	Typical $\pm 3\%$ of reading at ambient temperature of 25 ± 5 °C
Display Unit	Torr unless otherwise requested Adjustment and internal selector switch provides readout in mbar or pascal
Display Resolution	Scientific notation, 2 significant digits
Display Update Time	0.5 sec. typical as shipped. Internal switch selectable to 3 sec. reading averaged
Ion Gauge	
<i>Sensitivity</i>	3/Torr to 50/Torr (factory setting is 25/Torr)
<i>Emission Current</i>	10 μ A to 10 mA in 3 decade ranges (factory setting is 1 mA)
<i>Collector Potential</i>	0 V
<i>Grid Potential</i>	+180 V during normal operation +530 V during degas operation
<i>Filament Potential</i>	+30 V
<i>Degas EB</i>	40 watts approximate with 15 minute turn off timer
<i>Analog Output</i>	0-10 V; Logarithmic; 1V/decade
Remote I/O	
<i>Gauge and Degas On/Off Inputs</i>	Less than 0.4 V @ 10 μ A for 25 msec (min.). Must go to greater than 3.5 V for 105 msec (min.) before next low state
<i>Filament Status</i>	Optoisolator transistor, open collector and emitter, 40 VCEO, 200 mA

Chapter 3 Electrometer Module

3.1 Introduction

The ionization gauge (IG) Electrometer Module provides ion gauge pressure readout from less than 1×10^{-11} Torr (1.33×10^{-11} mbar or 1.33×10^{-9} pascal) to 1×10^{-2} Torr (1.33×10^{-2} mbar, 1.33 pascal), air equivalent, depending on the gauge and emission current used.

Adjustments are provided for gauge sensitivity and emission current. Adjustment and an internal switch allow change to mbar or Pascal pressure units, and a user selectable "slow update" feature triggers measurement averaging, resulting in a display update frequency of about once every three seconds. The overpressure shutdown threshold is internally adjustable. An internal switch defeats the 15 minute degas timer turn off feature.

3.2 Units of Measure

Your unit was shipped from the factory preset to display the unit of measure, torr, millibar or pascal, that you requested. If you wish to change units, proceed as follows:

1. Shut off power to the control unit.
2. Remove the top cover. Locate the IG Electrometer Module. (See Figure 3-1.)
3. Locate the display units control switch (#7).
4. Set the switch to the desired position; off = Torr/mbar units, on = Pascal units.
5. Slip the label card out of the top of the front panel and apply the appropriate pressure units label.

Selection between Torr and mbar units is done by adjusting the ionization gauge sensitivity to the appropriate units. For example, a typical nude Bayard-Alpert gauge has a sensitivity of 25/Torr or 18.75/mbar. Thus, for this gauge, adjusting the sensitivity for a display reading of 2.5+1 will result in display of pressure in Torr. Adjusting to 1.9+1 will result in display in mbar.

Figure 3-1 Electrometer Module Top View

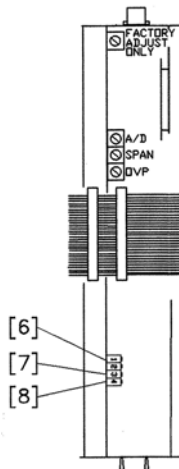

3.3 Display Update Rate Switch [8]

Locate [8] slow update switch. Setting this switch “ON” will enable pressure averaging. The display will update about every 3 seconds rather than the normal 0.5 sec. typical period.

3.4 Degas Timer Override [6]

Locate [6] degas timer override switch. Setting this switch “ON” will disable the 15 minute turn off timer.

3.5 Calibration Switch [9]

This switch is used for displaying pressure, gauge sensitivity or emission current. It is activated by setting either to the left or right of the center (CAL) position. The function depends on the operating state of the ion gauge tube. If the tube is off, setting the switch displays the tube sensitivity in scientific notation. If the tube is on, the switch displays emission current in amperes. Note the display will blink at a two second rate in this mode to warn the user that pressure is not being displayed.

!
CAUTION

Do not leave the calibration switch set in the CAL position after you are done viewing sensitivity or emission. Otherwise, the displayed CAL reading might be mistaken for an actual pressure reading.

Figure 3-2 Electrometer Module Front Panel

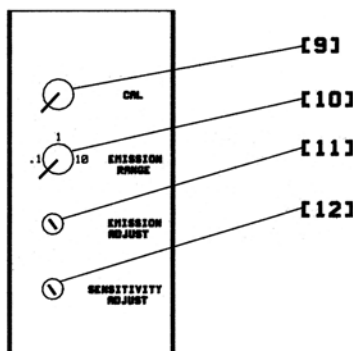

3.6 Emission Range Switch [10]

This switch selects between three emission ranges; 0.1 milliamperere, 1.0 milliamperere, or 10.0 milliampereres. Adjustment within each range is achieved with the emission adjustment pot.

In general, higher emissions are used at lower pressures. If you are measuring very low pressures or have a low-sensitivity IG tube, the 10.0 mA range is better. This is true even for a nude Bayard-Alpert gauge having a sensitivity of 25/Torr. The 10 mA of emission will generate additional ions and improve the signal to noise ratio of the electrometer without appreciably affecting filament life.

Note that changing the emission range by one decade will also change the overpressure shutdown point by one decade. See page 39 for details of the overpressure shutdown adjustment. Adjustment of emission within a range (see below) will not affect the overpressure shutdown point.

3.7 Emission Adjustment [11]

This potentiometer provides control of the emission within the decade value selected by the emission range switch. The calibration switch must be set with the IG tube turned on to view emission during adjustment. The span of adjustment is from approximately 10% to 120% of the range value.

Please note that on some earlier generation IG controllers, the emission current adjustment was used to correct for varying tube sensitivities. This is not appropriate on the controller, as an independent sensitivity adjustment is provided (see below).

Theoretically, varying the emission current will not affect the pressure reading since the electrometer is actually calculating:

$$P = \frac{I}{S(1 - I)}$$
$$\text{Pressure} = \frac{\text{Collector current}}{\text{Sensitivity} \times \text{Emission current}}$$

There will be slight differences, depending on gauge cleanliness and gauge pumping.

3.8 Sensitivity Adjustment [12]

This adjustment is used to match tubes of different sensitivities. The calibration switch [9] must be set left or right with the IG off to view sensitivity during the adjustment.

The controller is shipped from the factory set for a tube sensitivity of 25/Torr, as is typical for nude Bayard-Alpert type tubes such as the Granville-Phillips 274022 and 274023. The approximate range of the adjustment is 3 to 50/Torr. If the actual 'S' of the gauge tube being used is different than 25/Torr, the sensitivity adjustment should be set to that of the gauge tube; otherwise, measurement error will result.

3.9 Relative Gas Sensitivities

Sensitivity depends on the gas being measured as well as the type of IG tube. Table 3-1 lists the relative gauge sensitivities for common gases. These values are from NASA Technical Note TND 5285, *Ionization Gauge Sensitivities as Reported in the Literature*, by Robert L. Summers, Lewis Research Center, National Aeronautics and Space Administration. Refer to this technical note for further definition of these average values and for the gauge sensitivities of other gases.

To adjust the controller to be direct reading for gases other than air or N₂, calculate the sensitivity K_x for gas type x as follows:

$$K_x = (R_x)(KN_2)$$

Where KN₂ is the gauge sensitivity for N₂ and R_x is found in Table 3-1.

Table 3-1 Relative Gas Sensitivities

Gas	R _x	Gas	R _x
He	0.18	H ₂ O	1.12
Ne	0.30	NO	1.16
D ₂	0.35	Ar	1.29
H ₂	0.46	CO ₂	1.42
N ₂	1.00	Kr	1.94
Air	1.00	SF ₆	2.5
O ₂	1.01	Xe	2.87

3.10 Analog Output

This voltage is proportional to the logarithm of the pressure, scaled to 1 volt per decade with 0 volts at 1×10^{-12} Torr at 10 mA emission current. Emission range setting affects the scaling of the analog output (see Figure 3-3. When the IG is turned off, the output will switch to slightly over +10 V.

A standard 1/8" miniature phone jack connector is supplied.

- For 10 mA emission, Pressure = $10^{(V-12)}$
- For 1 mA emission, Pressure = $10^{(V-11)}$
- For 0.1mA emission, Pressure = $10^{(V-10)}$

Figure 3-3 Analog Outputs (in V)

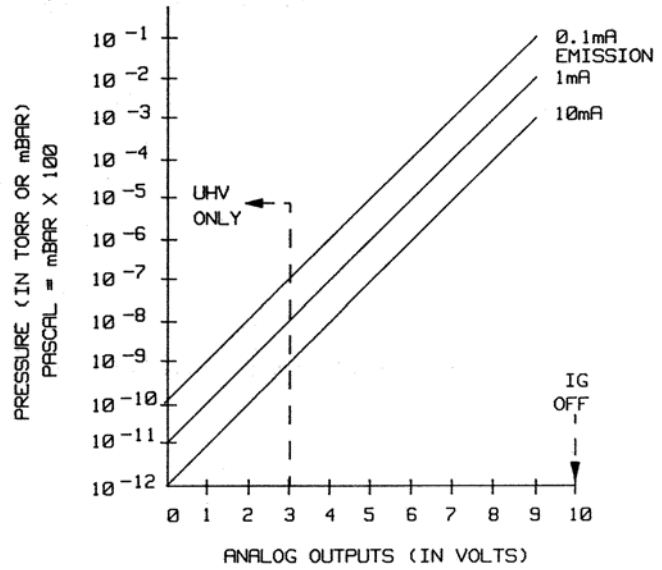
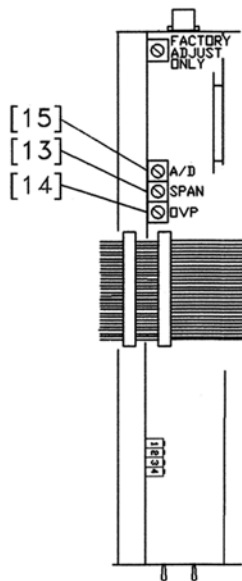

Figure 3-4 Ion Gauge Electrometer Module



3.11 Electrometer Calibration

See pages 35 and 36 for instructions on calibrating ion gauge sensitivity and emission current.

Electrometer Span Adjustment [13]

This is a factory calibration point and should not normally be changed by the user.

Overpressure Shutdown Adjustment [14]

This control is factory set so the ion gauge will shut down when the pressure rises above the levels listed in Table 3-2.

Table 3-2 Overpressure Shutdown Values

Emission Current (milliamperes)	Overpressure Point
0.1 mA range	1.0 x 10 ⁻³ 1.33 x 10 ⁻³ mbar 1.33 x 10 ⁻¹ pascal
1.0 mA range	1.0 x 10 ⁻⁴ 1.33 x 10 ⁻⁴ mbar 1.33 x 10 ⁻² pascal
10.0 mA range	1.0 x 10 ⁻⁵ 1.33 x 10 ⁻⁵ mbar 1.33 x 10 ⁻³ pascal

The overpressure shutoff point does not depend on the adjustment of the emission level within a range.

To adjust the overpressure shutoff point to a different level:

1. Maintain system pressure at the desired shutoff point.
2. Rotate the overpressure adjustment potentiometer fully counter-clockwise.
3. Turn on the ion gauge.
4. Rotate the adjustment pot clockwise slowly until the ion gauge turns off.

A/D calibration [15]

Factory set, do not adjust.



WARNING

Failure to install appropriate pressure-relief devices for high-pressure applications can cause an equipment malfunction resulting in measurement error, property damage, or personal injury.

If an equipment malfunction could cause a hazardous situation, always provide for fail-safe operation. For example, in an automatic backfill operation where a malfunction might cause high internal pressures, install appropriate pressure relief devices.

4.1 Introduction

The process control module provides the controller with single-pole, double-throw relays that may be controlled either by digital setpoints or by the built-in manual override switches.

4.2 Process Control System Connections

Prior to connecting the process controls to the system, it is recommended that the following steps be followed. If application assistance is desired, contact a Brooks Automation, Inc./Granville-Phillips application engineer.

1. Unless the control logic is simple and obvious, develop a logic diagram of the process control function.
2. Prepare a specification table which lists the proposed pressure setting, system measurement point, and polarity for each process control channel.
3. Draw a circuit schematic which specifies exactly how each piece of system hardware will be connected to the process control relays.
4. Check that the power required for the load is within the specified ratings of the relay.
5. With the process control module connector disconnected from the process control module, connect the process control cable to the devices to be controlled.
6. Ensure that all devices are under manual control before connecting to the process control module.

4.3 To Display a Setpoint

1. Be sure the "CAL" switch of the electrometer is in its center position, or the calibration data in display line 1 will conflict with the display of setpoints 1 and 2.
2. Set selector switch [19] to the number of the channel you wish to display.

4.4 To Modify a Setpoint

3. Press either setpoint display/set button, [17] or [18] and release. The setpoint will appear for 2 seconds in the same display.
1. Set the selector switch [19] to the number of the channel you wish to modify.
 2. Press and hold the setpoint SET button for the direction you wish the setpoint to change, up, [17] to raise the setpoint, down, [18] to lower it.
 3. The setpoint will scroll until the button is released. It will scroll slowly until a decade boundary is crossed and then will speed up to facilitate rapid changes across many decades. Release the button when you have entered the desired decade, and then re-depress it to scroll slowly within the decade to reach the exact setpoint needed.

Figure 4-1 Process Control Module Front Panel

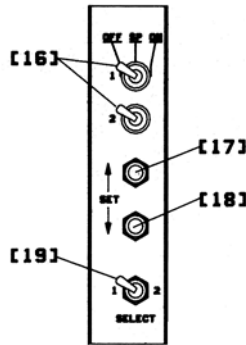

After the setpoint button is released, the display will return to pressure data after two seconds. At this time the new setpoint will be deposited in non-volatile memory.

Note that if the ion gauge is off, PC relays 1 and 2 will de-activate.

4.5 Relay Polarity Setting

The relays can be set to activate with pressure either above or below the setpoint. A switch is provided for each channel. For activation below the setpoint, the switch should be in the OFF position. This is the factory setting. Refer to the numbers on the printed circuit board – not on the switch body itself--for the number.

For two channel process control, switches 1 and 2 set the polarity for setpoints 1 and 2.

Figure 4-2 Process Control Module, Top View

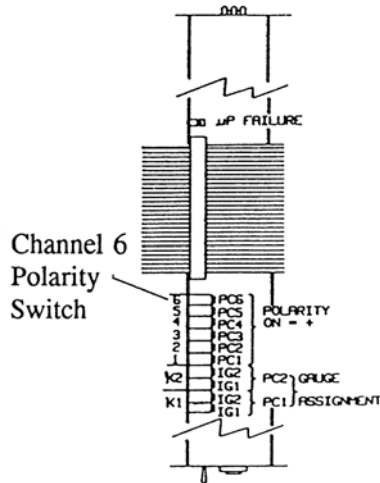

4.6 Relay Disable

The K1 pair of switches can be used to enable or disable PC1. Set both switches to OFF to enable PC1 to be activated by the IG pressure. Setting both switches ON will set the PC1 relay to be always off. K2 switches control PC2 similarly. The switches are factory set to enable the relays. The following figure shows the status of the process control relay contacts for the ON and OFF conditions.

See Figure 4-3 for process control connector relay contact/pin assignments.

Figure 4-3 Pin Assignments/Process Control Connector

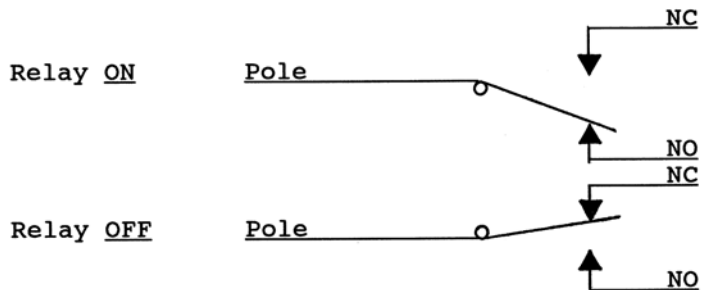

PC Module

4.7 Pin Assignments

Table 4-1 lists pins on the process control module rear panel connector.

Table 4-1 Rear Panel Pin Assignments

Pin Letter	Function
W	Channel 1 relay common
P	Channel 1 relay N.C.
T	Channel 1 relay N.O.
H	Channel 2 relay common
A	Channel 2 relay N.C.
D	Channel 2 relay N.O.

4.8 Process Control Operation

The status of the 2 relays is displayed at all times in the relay status LEDs on the controller front panel. Note that these LEDs do not indicate whether the gauge pressure is above or below the programmed setpoint, since manual override status may result in activation above or below the setpoint.

Setpoint Display and Adjustment

Setpoints are stored in non-volatile memory, and are specified by a 2-digit mantissa and 2-digit exponent. They may be set anywhere in the range 1×10^{-12} to 9×10^5 . This allows for the entire pressure range of all supported transducer types and systems of units.

The setpoint is compared directly to the display data, so units of measure are implicit. Changing the units switch on the gauge control modules will not change the stored setpoints. They must be re-programmed in the new system of units.

No change in status of relays 1 and 2 will occur during degas. They will function as if the pressure was frozen at the instant degas was initiated. This is because large pressure variations may occur in an ion gauge tube under degas.

There is a programmed 10% hysteresis on each process control setpoint. For example, with a pressure setpoint of 6.3×10^{-6} Torr the relay will activate when the display reaches 6.2×10^{-6} Torr (for falling pressure) and will de-activate when the pressure rises to one significant digit above the setpoint plus 10%, i.e., $6.3 \times 10^{-6} + 0.6 \times 10^{-6} + 0.1 \times 10^{-6}$ or 7.0×10^{-6} Torr. For setpoints where the 2nd digit is 0.5 or greater the 10% value is rounded up. For example, if the setpoint is programmed to 6.6×10^{-6} Torr the relay will activate at 6.5×10^{-6} Torr (on falling pressure) and will de-activate when the pressure rises to $6.6 \times 10^{-6} + 0.7 \times 10^{-6} + 0.1 \times 10^{-6}$ or 7.4×10^{-6} Torr.

Since the process control and computer interface modules derive their pressure data directly from the display bus, they will be unable to update their pressure data while setpoints are being displayed. They will not

mistakenly interpret setpoint data as pressure data, but will simply retain the last displayed pressure data until the SET key is released.

Manual Override [16]

These two three-position switches on the front of the process control module allow override of the programmed setpoints at any time. When moved to the right, the relay is activated. When moved to the left, the relay is de-activated. When left in the center position, the relay is controlled automatically.

4.9 Process Control Theory of Operation

The process control module contains a dedicated micro controller and a non-volatile memory chip for storage of the setpoints. This chip has a rated life of 10,000 erase/write cycles for each setpoint, and will retain data for 10 years. Since data is read/written to this chip serially, it is necessary to store working copies of the setpoints in internal RAM memory.

The micro controller compares the setpoints with the pressure display data on the display bus and makes a decision as to whether or not to activate a channel's relay.

The manual override switches, when thrown in one direction or the other, take precedence over the micro controller's decision.

Process Control Specifications

Number of channels	2
Pressure range	1.0×10^{-12} to $9.9 \times 10^{+5}$
Hysteresis	10%
Setpoint adjustment	Digital, 2 significant digits plus exponent
Output relays contact rating	5 A @ 30 VAC or 5 A @ 30 Vdc, resistive load
Output relays contact type	SPDT

Chapter 5 RS-232 Module

5.1 Introduction

The RS-232 interface module for the controller allows data output to, and ion gauge control by, a host computer. Output is either by a command-response mechanism or by a talk-only mode which is invoked via a switch on the RS-232 board.

A variety of baud rates and byte framing options are available, as well as switches to force the handshake lines to an “always true” condition.

5.2 RS-232 Interface

RS-232 factory defaults are: 300 BAUD, 7 data bits, no parity, 2 stop bits; DCD, CTS, DSR forced “true.”

The interface protocol is set using 8 switches. Figure 4.1, reference [20], designates switch number 1.

Selecting the Byte Format

Baud Rate

Dip switches 6 through 8 control the baud rate, as listed in Table 5-1.

Table 5-1 Baud Rate Switch Settings

Switch 6	Switch 7	Switch 8	Baud Rate	Switch 6	Switch 7	Switch 8	Baud Rate
On	On	On	9600	Off	On	On	600
On	On	Off	4800	Off	On	Off	300
On	Off	On	2400	Off	Off	On	150
On	Off	Off	1200	Off	Off	Off	75

Character Framing

Switches 3-5 control number of characters, parity, and number of stop bits, as listed in Table 5-2.

Table 5-2 Character Framing Switch Settings

Switch 3	Switch 4	Switch 5	Character Bits	Parity	Stop Bits
On	On	On	8	None	2
On	On	Off	8	Even	1
On	Off	On	8	Odd	1
On	Off	Off	7	None	2
Off	On	On	7	Even	1
Off	On	Off	7	Odd	1
Off	Off	On	7	Even	2
Off	Off	Off	7	Odd	2

Talk-Only Mode

Switch S1 [20], if OFF at power-up, puts the interface in talk-only mode. The pressure data from all three displays will be output in a single message string, separated by commas, approximately every 5 seconds.

Handshake Line Control Switches

See page 51 for more detailed information on the handshaking mechanism. Switches [22],[23], and [24], when in the up position, force the handshake lines data-carrier-detect (DCD), clear-to-send (CTS), and data-set-ready (DSR), respectively, to a logic true condition.

As shipped from the factory, these lines are forced true.

Figure 5-1 RS-232 Top View

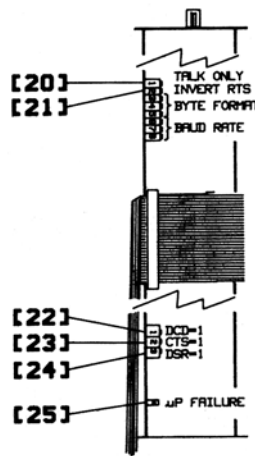

Invert RTS Switch

As shipped from the factory, the request-to-send (RTS) control line is set to operate as a modem line per the RS-232 standard. In some implementations it is necessary to invert this line and hook it directly to the clear-to-send (CTS) line of the host computer.

Switch S2, if OFF when the controller goes through its power-up sequence, tells the RS-232 interface to invert the polarity of the RTS line.

5.3 Operation

Consult the user's manual for the host computer to be sure the protocol used is in accord with that established via the switch configuration you have chosen for the RS-232 module.

Communication with the controller is via ASCII strings. A message to the controller consists of a command and a command modifier, followed by a terminator. The message may contain leading spaces, and the command and modifier may optionally be separated by spaces or commas. No spaces may appear within the command or the modifier, only between them.

The terminator expected by the controller is an ASCII carriage return line feed, denoted here by the \downarrow symbol. The carriage return is optional, and messages terminated with only the line feed will be accepted. Note that the CRLF terminator is, in general, appended automatically by the host computer's interface software to the message string supplied by the user.

If extra characters are found in the message after it has been successfully interpreted but before the terminator, they will be ignored.

All characters should be upper-case.

All messages to the controller will receive a reply, consisting of an ASCII string terminated with CRLF. Numbers will be returned in the format X.XXE±XX.

Command Syntax

DG

Definition:	Turn degas on or off
Modifiers:	1 or 0
Response:	OK if command accepted, or INVALID if rejected
From computer:	DG ON \downarrow
From controller:	OK \downarrow

- Command is INVALID if IG is not on.
- A response to the DG ON command of OK indicates only that a signal requesting degas has been sent to the electrometer. Degas will fail to activate if the pressure is above 5×10^{-5} Torr or if your controller does not have degas capability. Use the DGS command (see below) to verify that degas has been successfully initiated.

DGS	<p>Definition: Display degas status</p> <p>Modifiers: None</p> <p>Response: 1 if degas is on, 0 if degas is off</p> <p>Example:</p> <p>From computer: DGS ↵</p> <p>From controller: 1 ↵ (Indicating degas is on)</p>
DS IG	<p>Definition: Display pressure reading</p> <p>Response: ASCII string representing the pressure</p> <p>Example:</p> <p>From computer: DS IG ↵</p> <p>From controller: 1.20E-07 ↵</p> <ul style="list-style-type: none"> • If the ion gauge is turned off, or is in its first few seconds of operation, the controller will return 9.90E+09. • The DS IG command will return pressure if either filament is on, and 9.90E+09 if neither is on.
IG1	<p>Definition: Turn IG filament 1 on or off</p> <p>Modifiers: ON or OFF</p> <p>Response: OK if command accepted, INVALID if rejected</p> <p>Example:</p> <p>From computer: IG1 ON ↵</p> <p>From controller: OK ↵</p> <ul style="list-style-type: none"> • The IG1 ON command will be rejected as INVALID if Filament 1 is already on, and IG1 OFF will be rejected if Filament 1 is already off. • A response to the IG1 ON command of OK indicates only that a signal requesting that Filament 1 be turned on has been sent to the electrometer. The tube may fail to come on, e.g., if the system pressure is too high or if the tube is disconnected. To verify that Filament 1 is on, use the DS IG1 command. If the tube is off (or in its first few seconds of operation after being turned on) a pressure of 9.90E+9 will be returned.
IG2	<p>Identical to IG1, but applies to Filament 2.</p>

Error Messages

If an error is found in the incoming message, the following messages will be returned in place of the normal response:

OVERRUN ERROR␣

Returned if the incoming message overflows 350's buffer. This may indicate a flaw in the host software.

PARITY ERROR␣

Returned if the parity of a byte in the incoming message does not match that programmed by the switches.

SYNTAX ERROR␣

Returned if the message fails to parse as a valid controller command. Also returned as a result of failure to assert DCD during transmission.

5.4 RS-232 Theory of Operation**Handshaking**

The RS-232 interface implements the signals listed in Table 5-3.

Table 5-3 RS-232 Control Lines

Signal	Pin Number	Direction
Protective Ground	1	None
Transmitted Data	2	To computer
Received Data	3	To controller
Request to Send (RTS)	4	To computer
Clear to Send (CTS)	5	To controller
Data Set Ready (DSR)	6	To controller
Signal Ground (common return)	7	None
Data Carrier Detect (DCD)	8	To controller
Data Terminal Ready (DTR)	20	To computer

The DTR line is set true on power up to indicate it is on line. When the controller receives a start bit on the received data line it will input and buffer a character. The DCD line must be true at the time each character is received or that character will be ignored. The controller will continue to receive and buffer characters until the terminator (LF) is received.

Upon receiving the terminator, the controller will assert the RTS line as a holdoff, to prevent the host computer from attempting to transmit further data until the message just received has been decoded and a reply has been output.

During output of the reply, the incoming handshake lines CTS, and DSR are tested prior to beginning transmission of each character. The controller will wait until both are true before beginning transmission of a character, and will not test them again until ready to begin transmitting the next.

After transmitting the terminator, the controller will negate RTS and wait for the next incoming message.

To summarize:

CTS, DSR Set by the computer to indicate that the controller may output the next byte in its message. As shipped from the factory these lines are forced “true” by the switch settings of the RS-232 printed circuit board, thus the controller will automatically assume the host is ready to receive. See Fig. 4.1 for the location of these switches.

DCD Tested when a character is received. The character will be ignored unless DCD is “true.” As shipped from the factory this line is forced “true” by the switch settings.

DTR Always asserted by the controller. A power on indication.

RTS Negated by the controller on power-up. Asserted upon receipt of a message terminator. Negated after transmitting the terminator of the controller's response to that message.

5.5 Reversing the Polarity of RTS If switch 2, [21], is open on power-up, the controller will apply the opposite polarity to RTS from that described above. When used in this mode RTS may be connected to the CTS input of the host computer. This violates the RS-232 standard, but is a commonly used implementation.

5.6 RS-232 Troubleshooting Because the RS-232 standard is found in a bewildering array of configurations, the first thing to do if trouble arises is check the following configuration options:

1. Check switch settings.
Be sure baud rate, character format and framing, and interface protocol are matched to your host computer or terminal's requirements. Note that there may be several mismatched parameters. Check to see if your computer requires the reversed-polarity RTS convention.

2. Check interface wiring.
The pin designations for the RS-232 connector are listed in Table 5-3. Note that the “received” and “transmitted” data lines are defined as seen by the controller. Many companies supply “null modems” or switch boxes for the purpose of reconfiguring the control lines for particular applications.

3. Check command format.

Be sure the strings you output to the controller are in accord with the syntax defined in *Command Syntax*, page 49.

Table 5-4 RS-232 Troubleshooting Guide

Symptom	Possible Cause
Micro controller reset LED [25] lit or flashing	Micro controller failure
No response or garbled output	Baud rate incorrect. Character length incorrect or stop bit(s) incorrect.
OVERRUN ERROR message	Stop bit(s) incorrect, host software failure.
PARITY ERROR message	Parity incorrect.
SYNTAX ERROR message	<ul style="list-style-type: none"> • Message to the controller not in accord with specified syntax. • Failure to assert DCD handshake line.

RS-232 Specifications

Format	EIA standard RS-232-C, half duplex, asynchronous
Data Rates	75,150,300,600,1200,2400,4800,9600 baud
Character length	7 or 8 bit ASCII, switch selectable
Parity	Odd, even, or none, switch selectable
Stop bits	<ul style="list-style-type: none"> • 1 or 2 • 8 character bits plus parity allows only 1 stop bit
Handshake	<ul style="list-style-type: none"> • Outputs: DTR,RTS. RTS polarity selectable • Inputs: DSR, CTS, DCD. May be forced to logic "TRUE" with switches
Logic levels	<ul style="list-style-type: none"> • Inputs: Logic 1, 2.0 Vdc min., 15 Vdc max. • Logic 0, -15 Vdc min., 0.75 Vdc max.
Input Current	4.0 mA max @ $V_{in} = +15$ Vdc, 4.0 mA max @ $V_{in} = -15$ Vdc

Chapter 6 Digital Interface Module

The Process Control and RS-485 or RS-232 Module for the Series 350 UHV Controller allows data output to, and gauge control by, a host computer. Output is by a command-response mechanism. Process control features of this module provide the controller with single-pole, double-throw relays that may be controlled either by digital setpoints or by the built-in manual override switches.

6.1 Process Control Installation



WARNING

Failure to install appropriate pressure-relief devices for high-pressure applications can cause an equipment malfunction resulting in measurement error, property damage, or personal injury.

If an equipment malfunction could cause a hazardous situation, always provide for fail-safe operation. For example, install appropriate pressure relief devices in an automatic backfill operation where a malfunction might cause high internal pressures.

6.2 Process Control System Connections

Prior to connecting the process controls to the system, it is recommended that the following steps be followed. If application assistance is desired, contact a Brooks Automation, Inc./Granville-Phillips application engineer.

1. Unless the control logic is simple and obvious, develop a logic diagram of the process control function.
2. Prepare a specification table which lists the proposed pressure setting, system measurement point, and polarity for each PC channel.
3. Draw a circuit schematic which specifies exactly how each piece of system hardware will be connected to the controller process control relays.
4. Check that the power required for the load is within the specified ratings of the relay.
5. With the process control module connector disconnected from the open board, connect the process control cable to the devices to be controlled.
6. Ensure that all devices are under manual control before connecting to the process control module.

6.3 To Display a Setpoint

1. Be sure the “CAL” switch of the electrometer is in its center position; otherwise, the calibration data in display lines 1 and 2 will conflict with the display of the setpoints.
2. Set selector switch to the number of the channel you wish to display.
3. Toggle the setpoint set switch to either the up or down position and release. The setpoint will appear for 2 seconds in the corresponding display.

6.4 To Modify a Setpoint

1. Set the selector switch to the number of the channel you want to modify.
2. Toggle and hold the setpoint SEP switch for the direction you want the setpoint to change.
3. The setpoint will scroll until the switch is released. It will scroll slowly until a decade boundary is crossed and then will speed up to facilitate rapid changes across many decades. Release the switch when you have entered the desired decade, and then depress it again to scroll slowly within the decade to reach the exact setpoint needed.

Figure 6-1 Process Control & RS-232, or RS-485 Module Front and Rear Panels

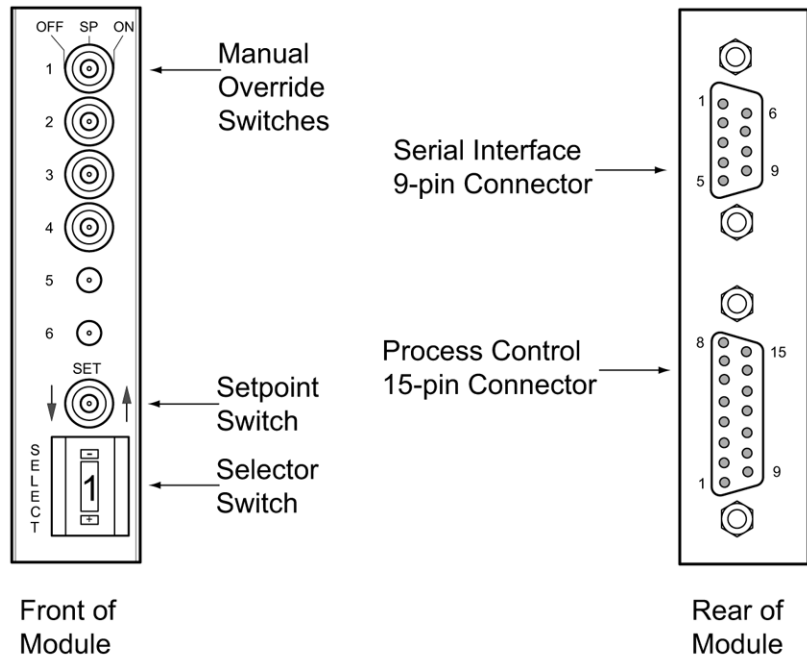

After the setpoint switch is released, the display will return to pressure data after two seconds. At this time the new setpoint will be deposited in non-volatile memory.

Note that if the ion gauge is off, any PC relay which is programmed to the top display will deactivate.

6.5 Process Control Connector

The following pins are used for the process control relay contacts. This is a D15-P and is the lower connector on the rear panel of this module.

Table 6-1 Process Control Connector (D-15P)

Process Control Channel	Channel 1	Channel2	Channel 3	Channel 4
Common	10	13	3	6
Normally closed	12	2	5	8
Normally open	9	1	4	7

Chassis ground, Pin 11; No connection, pins 14 and 15.

6.6 Process Control Display Assignment

Each process control channel can have its setpoint assigned to any one of the three display lines of the controller. Two sections of switch block S9 are used to choose the display assignment for each channel according to Table 6-2.

Table 6-2 Process Control Display Assignment

Process Control	Switch A	Switch B	Factory Setting
PC1	S9.1	S9.2	Top
PC2	S9.3	S9.4	Top
PC3	S9.5	S9.6	Middle
PC4	S9.7	S9.8	Bottom
Display	Switch A	Switch B	Factory Setting
Top	ON	ON	None (not applicable)
Middle	ON	OFF	None (not applicable)
Bottom	OFF	ON	None (not applicable)
Disabled	OFF	OFF	None (not applicable)

Example: To program setpoint 3 to operate with the middle readout, S9.5 = ON, S9.6 = OFF.

- 6.7 Manual Override** These three-position switches on the front of the PC/RS-485/RS-232 module allow override of the programmed setpoints at any time. When moved to the right, the relay is activated. When moved to the left, the relay is deactivated. When Left in the center position, the relay is controlled automatically.

- 6.8 RS-232/RS-485 Installation** Table 6-3 lists factory settings for RS-232 and RS-485 communication.

Table 6-3 RS-232 and RS-485 Communication Defaults

Variable	Default Setting
Baud rate	9600 baud
Parity	None
RS-485 address	01
Character bits	8
Stop bits	1
Protocol	RS-232 protocol

Figure 6-2 Process Control, RS-232, and RS-485 Interface Connectors

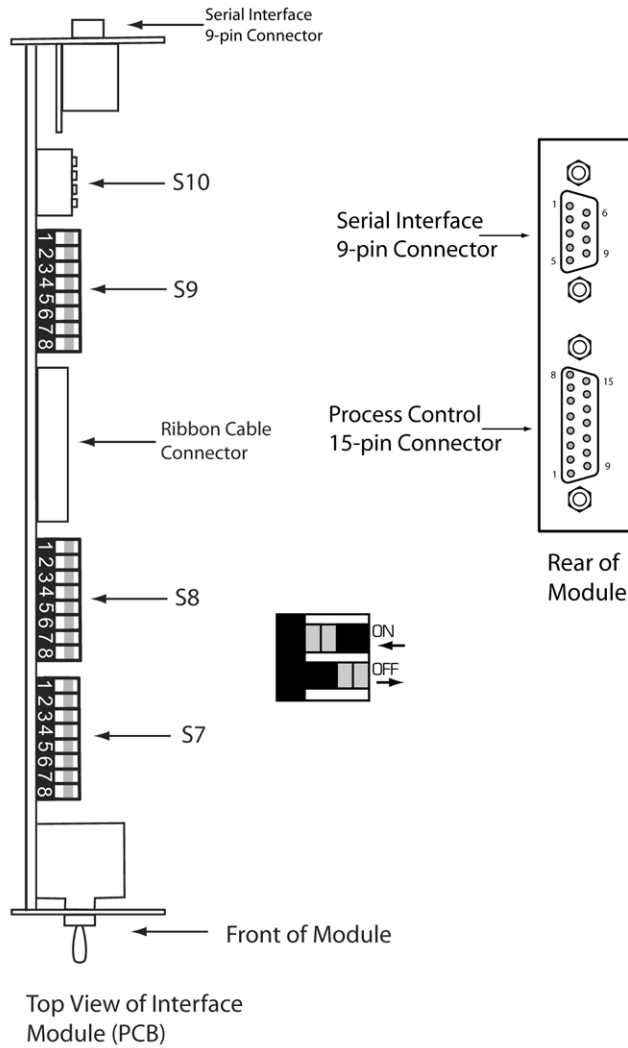

6.9 Setpoint Display and Adjustment

Setpoints are stored in non-volatile memory, and are specified by a 2-digit mantissa and 2-digit exponent. They may be set anywhere in the range 1×10^{-2} to 9×10^5 . This allows for the entire pressure range of all supported transducer types and systems of units.

The setpoint is compared directly to the display data, so units of measure are implicit. Changing the units switch on the gauge control modules will not change the stored setpoints. They must be reprogrammed in the new system of units.

No change in status of any relay programmed to the top display will occur during degas. It will function as if the pressure were frozen at the instant degas was initiated.

There is a programmed 10% hysteresis on each process control setpoint. For example, with a pressure setpoint of 6.3×10^{-6} Torr the relay will activate when the display reaches 6.2×10^{-6} Torr and will deactivate when the pressure rises to one significant digit above the setpoint plus 10%, i.e., $6.3 \times 10^{-6} + 0.6 \times 10^{-6} + 0.1 \times 10^{-6}$ or 7.0×10^{-6} Torr. For setpoints where the second digit is 0.5 or greater the 10% value is rounded up. For example, if the setpoint is programmed to 6.6×10^{-6} Torr the relay will activate at 6.5×10^{-6} Torr and will deactivate when the pressure rises to $6.6 \times 10^{-6} + 0.7 \times 10^{-6} + 0.1 \times 10^{-6}$ or 7.4×10^{-6} Torr.

Since this module derives pressure data directly from the display bus, it is unable to update pressure data while setpoints are being displayed. Thus it will not mistakenly interpret setpoint data as pressure data, but will simply retain the last displayed pressure data until two seconds after the SET key is released.

6.10 Switch Settings

Table 6-4 details the functions and settings of the four blocks of DIP switches located along the top edge of the module. To access these switches, remove the top cover per the instructions in the controller instruction manual. Each switch block is labeled with silk screening on the pc board and each switch is numbered on the block. Setting of switch S10 may only be changed when power to the controller is off.

Table 6-4 Module Switch Functions and Settings**S7**

Switch	Function	Factory Setting
1	Not used	
2	Interface select: RS-232 = OFF; RS-485 = ON	OFF
3	Invert RTS handshake: Invert = OFF	ON
4	Controller series: 350 controller = ON	ON
5	RS-485 address — See Table 6-7	OFF
6	RS-485 address — See Table 6-7	ON
7	RS-485 address — See Table 6-7	ON
8	RS-485 address — See Table 6-7	ON

S8

Switch	Function	Factory setting
1	Talk only mode (R5232 only): Enabled = OFF	ON
2	RS-485 address — See Table 6-7	ON
3	Character framing — See Table 6-6	ON
4	Character framing — See Table 6-6	OFF
5	Character framing — See Table 6-6	OFF
6	Baud rate — See Table 6-5	ON
7	Baud rate — See Table 6-5	ON
8	Baud rate — See Table 6-5	OFF

Table 6-4 Module Switch Functions and Settings (continued)**S9**

Switch	Function	Factory Setting
1	PC 1 display assignment — See Table 6-2	ON
2	PC 1 display assignment — See Table 6-2	ON
3	PC 2 display assignment — See Table 6-2	ON
4	PC 2 display assignment — See Table 6-2	ON
5	PC 3 display assignment — See Table 6-2	ON
6	PC 3 display assignment — See Table 6-2	OFF
7	PC 4 display assignment — See Table 6-2	OFF
8	PC 4 display assignment — See Table 6-2	ON

S10

Switch	Function	Factory Setting
1	RS-232/RS-485 drivers — UP = RS-232; DOWN = RS-485	UP
2	RS-232/RS-485 drivers — UP = RS-232; DOWN = RS-485	UP
3	RS-232/RS-485 drivers — UP = RS-232; DOWN = RS-485	UP
4	RS-232/RS-485 drivers — UP = RS-232; DOWN = RS-485	UP

Table 6-5 Baud Rate Switch Settings

Switch 8.6	Switch 8.7	Switch 8.8	Baud Rate
ON	ON	ON	19200
ON	ON	OFF	9600*
ON	OFF	ON	4800
ON	OFF	OFF	2400
OFF	ON	ON	1200
OFF	ON	OFF	600
OFF	OFF	ON	300
OFF	OFF	OFF	150

* Factory setting.

Table 6-6 Character Framing Switch settings

Switch 8.3	Switch 8.4	Switch 8.5	Character Bits	Parity	Stop Bits
ON	ON	ON	8	None	2
ON	ON	OFF	8	Even	1
ON	OFF	ON	8	Odd	1
ON	OFF	OFF	8	None	1*
OFF	ON	ON	7	Even	1
OFF	ON	OFF	7	Odd	1
OFF	OFF	ON	7	Even	2
OFF	OFF	OFF	7	Odd	2

* Factory setting.

Table 6-7 RS-485 Address Switch Settings

Decimal Value	Hex Value	Binary Value	Switch Settings				
			Switch 8.2	Switch 7.8	Switch 7.7	Switch 7.6	Switch 7.5
1	01	00001	ON	ON	ON	ON	OFF
2	02	00010	ON	ON	ON	OFF	ON
4	04	00100	ON	ON	OFF	ON	ON
8	08	01000	ON	OFF	ON	ON	ON
16	10	10000	OFF	ON	ON	ON	ON

S7.3 selects the polarity of the RTS handshake line. Normal (EIA standard) RTS is with S7.3 = ON; inverted RTS is with S7.3 = OFF. This function is used only with RS-232.

The maximum total cable length for RS-485 is 4000 ft. The maximum number of devices connected is 32.

6.11 RS-232 Connectors

Serial interface connector, J2, is configured for DCE operation when in RS-232 mode.

Table 6-8 RS-232 Connector Pinout

J3 pin number	Mnemonic	Name	DCE
1	DCD	Data carrier detect*	Output (ON)
2	RXD	Received data	Output
3	TXD	Transmitted data	Input
4	DTR	Data terminal ready*	Input (not used)
5	GND	Signal ground	N/A
6	DSR	Data set ready*	Output (ON)
7	RTS	Request to send*	Input
8	CTS	Clear to send*	Output
9	RI	Ring indicator*	Output (OFF)

* Optional connection.

RS-232 connections to a 9-pin IBM AT compatible may be made by using a straight through cable.

Table 6-9 9-pin RS-232 Connections

Signal Name	PC/AT Connector DB9 Male	Cable Pinout		Controller (DCE) DB9 Female
		DB9 Female	DB9 Male	
RXD	Pin 2	Pin 2	Pin 2	Pin 2
TXD	Pin 3	Pin 3	Pin 3	Pin 3
Signal ground	Pin 5	Pin 5	Pin 5	Pin 5
CTS	Pin 8	Pin 8	Pin 8	Pin 8
RTS	Pin 7	Pin 7	Pin 7	Pin 7

If the computer has a 25 pin connector, use the configuration listed in Figure 6-10.

Table 6-10 25-pin RS-232 Connections

Signal Name	PC/AT Connector DB9 Male	Cable Pinout		Controller (DCE) DB9 Female
		DB9 Female	DB9 Male	
RXD	Pin 3	Pin 3	Pin 2	Pin 2
TXD	Pin 2	Pin 2	Pin 3	Pin 3
Signal ground	Pin 7	Pin 7	Pin 5	Pin 5
CTS	Pin 5	Pin 5	Pin 8	Pin 8
RTS	Pin 4	Pin 4	Pin 7	Pin 7

To use a 3 wire interface, connect pin 7 to pin 8 on the controller and run only RXD, TXD and signal ground to the host computer.

6.12 RS-485 Connector

Connect TX on the gauge controller to RX on the host computer and connect RX on the gauge controller to TX on the host computer. Connect TX to TX and RX to RX on all instruments on the bus.

The polarity may have to be reversed on the computer and other instruments; you may have to try it both ways. No damage will result if connections are wrong.

Table 6-11 RS-485 Connector Pinout

Signal	Pin Number
+TX	2
-TX	8
+RX	3
-RX	7
Ground	5

6.13 Operation

Consult the user manual for the host computer to be sure the protocol used is in accord with that established via the switch configuration you have chosen for the controller RS-485 module.

Communication with the gauge controller is via ASCII strings. An RS-485 message to controller consists of a start character "#", an address, a command, and a command modifier, followed by a terminator. An RS-232 message to the controller is the same except the address is omitted. That is: A start character "#", a command, a command modifier, and a terminator.

The message may contain leading spaces, and the command and modifier may optionally be separated by spaces or commas. No spaces may appear within the command or the modifier, only between them.

The address expected by the controller is programmed via the switch settings of S7.5, S7.6, S7.7, S7.8, and S8.2. The syntax is “#AA” where AA is an ASCII representation of the hex address of the controller.

The terminator expected by controller is an ASCII carriage return denoted here by the ↵ symbol. Note that the terminator is sometimes appended automatically, by the host computer’s interface software, to the message string supplied by the user. If extra characters are found in the message after it has been successfully interpreted but before the terminator, they will be ignored.

All messages to controller with the appropriate address header will receive a reply, consisting of an ASCII string terminated with CR. Pressures will be returned in the format X.XXE±XX. All replies contain 11 characters including terminator.

Messages to controller may use upper or lower case alpha characters. The controller will always respond with upper case characters.

RS-232/RS-485 Command Syntax

- The syntax shown is for RS-485 protocol. The command syntax for RS-232 is the same as for RS-485 except that the address characters “AA” should not be sent.
- The ↵ symbol is the carriage return.

DG

Definition: Turn degas on or off
 Modifiers: 1 or 0
 Response: 1 DG ON or 0DG OFF if command accepted, or ? INVALID if rejected

Example:

From computer: #AADG1 ON↵
 From controller: * 1DG ON ↵

- Command is INVALID if IG is not on.
- A response to the DG1 command of 1DG ON indicates only that a signal requesting degas has been sent to the electrometer. Degas may fail to activate, e.g., if the pressure is above 5×10^{-5} Torr, or if your controller does not have degas capability. Use the DGS command (see below) to verify that degas has been successfully initiated.

DGS

Definition: Display degas status
 Modifiers: None
 Response: 1DG ON if degas is on, 0DG OFF if degas is off

	Example:	
	From computer:	#AADGS↵
	From controller:	* 1DG ON ↵ (Indicating degas is on)
IGB	Definition:	Display ion gauge status
	Modifiers:	None
	Response:	00 if filament is on 01 if filament 1 is on 10 if filament 2 is on
	Example:	
	From computer:	#AAIGS↵
	From controller:	* 01 ↵ (Indicating filament 1 is on)
RD	Definition:	Display pressure reading
	Modifiers:	1 or 2 or A or B or None
	Response:	ASCII string representing the pressure for the ion gauge requested
	Example:	
	From computer:	#AARD↵
	From controller:	* 1.20E-03↵
		<ul style="list-style-type: none"> • If the requested ion gauge is turned off, or is in its first few seconds of operation, the controller will return "9.90E+09". • RD1 returns filament 1 pressure, RD2 returns filament 2 pressure, RD returns whichever filament is on. EDA returns CGA (middle display) pressure, RDB returns CGB (bottom display) pressure.
F1	Definition:	Turn filament on or off
	Modifiers:	1 or 0
	Response:	11G1 ON or 01G1 OFF
	Example:	
	From computer:	#AAF1 1↵
	From controller:	* 11G1 ON ↵
		A response to the F1 command of 11G1 ON indicates only that a signal requesting that IG1 be turned on has been sent to the electrometer. The tube may fail to come on, e.g., if the system pressure is too high or if the tube is disconnected. To verify that IG1 is on, use the IGS command.
F2	Definition:	Like F1 command but for filament 2
PC	Definition:	Display process control channel status

Modifiers: 1 or 2 or 3 or 4 or B or S or ASCII string representing PC number and pressure

Response: Depends on modifier. The response will always be 11 characters long. The described response is followed by ASCII spaces then carriage return.

Table 6-12 PC Command Modifiers and Responses

Modifier	Response
Single digit (1 through 4)	Single ASCII digit <ul style="list-style-type: none"> • 0 if the corresponding relay is inactive • 1 if the corresponding relay is active
B	<ul style="list-style-type: none"> • A byte of data with bits 0 through 5 set/clear according to whether the corresponding relay is active/inactive • Bit 6 will always be set to guarantee that the returned byte will not appear as a terminator byte
S	A string of 4 ASCII zeroes and ones giving the status of all four channels <ul style="list-style-type: none"> • Binary 1 indicates the channel is active • Process control channel 1 is in bit 0
ASCII character string representing PC number and pressure	“* PROGM OK”

Examples: Assume that channels 1 through 3 are active, and 4 is inactive.

From computer: #AAPCS 1↵
 From controller: * 1 ↵

From computer: #AAPCS B↵
 From controller: * G ↵

The ASCII “G” corresponds to the bit pattern 01000111 and represents the status of the PC channels.

From computer: #AAPCS↵
 From controller: * 1110 ↵

Example for setting process control pressure setpoint:

From computer: #AAPC1_7.6E-06↵
 From controller: *_PROGM_OK↵

- Space between channel number and pressure is optional.
- Pressure syntax must have 2 mantissa digits separated by a period, an “E”, + or – sign, and 2-digit exponent.
- Other possible response is ? RAN FAIL. If this occurs, there may be a

defective non-volatile RAM but the setpoint will operate properly until power is cycled.

- Non-volatile memory requires approximately 1/2 second to cycle when this command is sent. Use the controller response to pace subsequent programming commands to prevent a failure in communication.

Error Messages

If an error is found in the incoming message, the following messages will be returned in place of the normal response:

? OVERR ER␣

Returned if the incoming message overflows 330's buffer. This may indicate a flaw in the host software.

? PRITY ER␣

Returned if the parity of a byte in the incoming message does not match that programmed by the switches.

? SYNTAX ER␣

Returned if the message fails to parse as a valid controller command.

? RAM FAIL␣

Returned after setpoint program if non-volatile RAM fails.

RS-232/RS-485 Signals

The controller RS-485 interface implements the following signals:

Table 6-13 RS-485 Connector Pinout

Signal	Pin Number
+TX	2
-TX	8
+RX	3
-RX	7
Ground	5

The timing of the RS-232 or RS-485 data transfer is shown in Figure 6-3.

Figure 6-3 RS-232 and RS-485 Data Timing

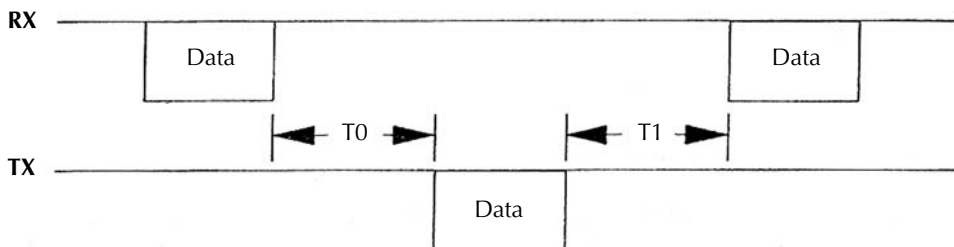

$T_0 = 500 \text{ ms}$ when PCX (pressure) command is sent. For all other commands, $T_0 = 630 \mu\text{s}$ minimum. $T_1 = 300 \mu\text{s}$ minimum.

The controller RS-232 mode implements the following signals:

Table 6-14 RS-485 Connector Pinout

Signal	Pin number	Direction
Data carrier detect*	1	Output
Received data	2	Output
Transmitted data	3	Input
Signal ground	5	Ground
Data set ready	6	Output
Request to send	7	Input
Clear to send	8	Output
Ring indicator	9	Output

The connector is wired for DCE operation. Signal names refer to the host computer. The output signals, DO, DSR are wired ON and RI is wired OFF. These signals do not change while power is applied. The output signal, CTS is ON after the controller is powered and software is ready to receive data. This signal then remains ON until power is removed. The input signal, RTS, controls the flow of data from the controller. If OFF, it will wait to send its response until turned ON. When RTS is turned ON, the controller will send its entire packet of data.

RS-232 and RS-485 Start Characters

The "*" or "7" start characters from the controller indicate a "good" or "bad" response, respectively. The host computer may take action dependent on which start character it receives. The response from the controller always contains 11 characters with a carriage return being the last.

The start character “#” from the host computer signals to the controller to reset its buffer for incoming data. If a string of data is received by the controller, including more than one “#”, only the data after the last “#” will be interpreted. The terminator character from the host computer signals to the controller to give its response.

6.14 Troubleshooting

The first thing to do if trouble arises is check the following configuration options:

1. Check interface cable connections.
2. Check switching settings. Be sure baud rate, character format and framing, and interface protocol are matched to your host computer or terminal’s requirements. Note that there could be several mismatched parameters.
3. Check command format. Be sure the strings you output to the controller are in accord with the syntax defined in the command syntax section.

Table 6-15 RS-232/RS-485 Troubleshooting Guide

Symptom	Possible Cause
Micro controller reset LED CR1 lit or flashing.	Microcontroller failure.
No response or garbled output.	Baud rate incorrect, character length incorrect or stop bit incorrect.
Will not respond intermittently.	Poor cable connections, ground fluctuations (the maximum common mode potential across the system is 7V) or EMI from other sources. If the start character is not received properly, the controller may not interpret it as a start character and the controller will not respond. Host software must be prepared to re-send a command if a response is not generated within a reasonable period of time.
OVERRUN ERROR message.	Stop bit(s) incorrect, host software failure.
PARITY ERROR message.	Parity incorrect.
SYNTAX ERROR message.	Message to controller not in accord with specified syntax.

Host Computer Interface Specifications

RS-232/RS-485 Specifications

<i>Format</i>	half duplex, asynchronous
<i>Data Rate</i>	19200, 9600, 4800, 2400, 1200, 600, 300, 150 baud
<i>Character length</i>	8 bit or 7 bit ASCII
<i>Parity</i>	No parity, even, or odd
<i>Stop bits</i>	1 or 2
<i>Handshake</i>	None
<i>Address</i>	0 through 31 selectable (RS-485 only)
<i>Number of connections</i>	Up to 32 devices (RS-485 only)
<i>Total cable length</i>	4000 ft. maximum (RS-485 only)
<i>Connector</i>	D-9S on module rear panel

Process Control Specifications

<i>Number of channels</i>	1 to 4
<i>Pressure range</i>	1.0×10^{-12} to 9.9×10^5
<i>Hysteresis</i>	10%
<i>Setpoint adjustment</i>	<ul style="list-style-type: none">• Digital, 2 significant digits plus exponent• Via module front panel or serial interface
<i>Output relays</i>	Activate below setpoint pressure
<i>Contacts</i>	1 A @ 120 VAC or 2A @ 30 Vdc
<i>Form</i>	SPDT
<i>Override</i>	Via module front panel switches
<i>Connector</i>	D-15P on rear panel of module

Chapter 7 Convectron Gauge Module

7.1 Introduction

This chapter provides you with the information required to install the Convectron gauge.

The gauge provides pressure measurement from 1.0×10^{-3} to 1000 Torr (1.33×10^{-3} to 1333 mbar, 1.33×10^{-1} to 1.33×10^5 pascal), and pressure measurement to one significant digit to 1×10^{-4} Torr (1.33×10^{-4} mbar, 1.33×10^{-2} pascal).



WARNING

Using the gauge to measure the pressure of flammable or explosive gases can cause a fire or explosion resulting in severe property damage or personal injury.

Do not use the gauge to measure the pressure of flammable or explosive gases.



WARNING

Exposing the gauge to moisture can cause fire or electrical shock resulting in severe property damage or personal injury.

To avoid exposing the gauge to moisture, install the gauge in an indoor environment. Do not install the gauge in any outdoor environment.

Some controller versions are configured to display pressure from an ion gauge and two Convectron gauges (A and B) when the two-channel Convectron module option is installed.

Figure 7-1 Typical Controller Front Panel with 3-Line Display and Process Control Status Indicators

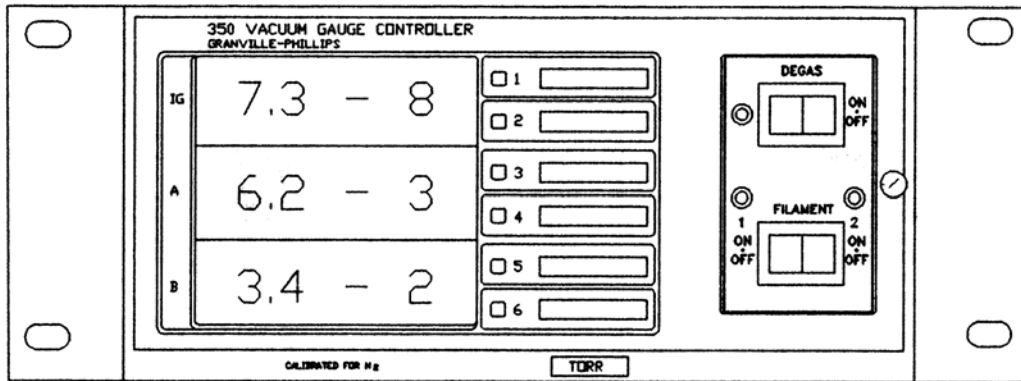
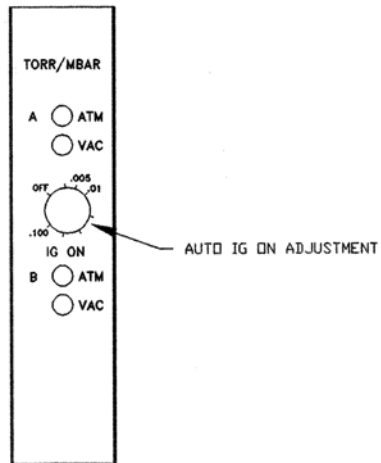

Figure 7-2 Convectron Option Front Panel



The Convectron module option can automatically turn ON filament 1 of the ion gauge. If automatic ion gauge ON is not desired, adjust the IG ON potentiometer to the OFF position (full CCW).

7.2 Safety Instructions

Explosive Gases

Do not use the gauge tube to measure the pressure of combustible gas mixtures. The sensing element normally operates at only 125 °C but it is possible that momentary transients or controller malfunction can raise the sensor above the ignition temperature of combustible mixtures which might then explode causing damage to equipment and injuring personnel.

Limitation on Use of Compression Mounts

Do not use a compression mount (quick connect) for attaching the gauge tube to the system in applications resulting in positive pressures in the gauge tube. Positive pressures might blow the tube out of a compression fitting and damage equipment and injure personnel. The Convectron gauge should not be used above 1000 Torr (1333 mbar or 1.33×10^5 pascal).

Tube Mounting Position

If the gauge tube will be used to measure pressures greater than 1 Torr or 1 mbar, the tube must be mounted with its axis horizontal. Although the gauge tube will read correctly below 1 Torr when mounted in any position, erroneous readings will result at pressures above 1 Torr if the tube axis is not horizontal. Erroneous readings can result in over or under-pressure conditions which may damage equipment and injure personnel.

Overpressure

Convectron gauges should not be used above 1000 Torr true pressure. Do not use above 1000 Torr true pressure. Series 307 instruments are furnished calibrated for N₂. They also measure the pressure of air correctly within the accuracy of the instrument. Do not attempt to use a Convectron gauge calibrated for N₂ to measure or control the pressure of other gases such as argon or CO₂, unless accurate conversion data for N₂ to the other gas is properly used. If accurate conversion data is not used or improperly used, a potential overpressure explosion hazard can be created under certain conditions.

For example, at 760 Torr of argon gas pressure, the indicated pressure on a Convectron gauge calibrated for N₂ is 24 Torr. At an indicated pressure of 50 Torr, the true pressure of argon is considerably above atmospheric pressure. Thus if the indicated pressure is not accurately converted to true pressure, it is possible to overpressure your system. Overpressure may cause glassware such as ionization gauges to shatter dangerously, and if high enough may cause metal parts to rupture thus damaging the system and possibly injuring personnel. See Section 3.3 for proper use of conversion data. A pressure relief valve should be installed in the system should the possibility of exceeding 1000 Torr exist.

High Indicated Pressure

For some gases, be aware the indicated pressure will be higher than the true pressure. For example, at a true pressure of 9 Torr for helium the indicated pressure on a Convectron gauge calibrated for N₂ is 760 Torr. The safe way to operate the gauge is to properly use accurate conversion data. See *Reading Pressure*, page 80 for proper use of conversion data.

Chemical

Cleaning solvents, such as trichloroethylene, perchloroethylene, toluene and acetone, produce fumes that are toxic and/or flammable. Use only in areas well ventilated to the outdoors and away from electronic equipment, open flames, or other potential ignition sources.

If the gauge tube becomes disconnected from the controller or if the sensor wire in the gauge tube fails, the controller will indicate 9.9E+9. If the tube is unplugged from a powered controller, there may be an instantaneous (0 to 0.2 seconds) drop in the pressure indication and the process control relays could activate for this brief time, depending on the order in which the tube pins break contact.

Gauge Tube Contamination

The calibration of the gauge will be seriously affected by any gas which will attack the gold plated sensor, and could result in over-pressuring the system. Two primary gases in this category are mercury vapor and fluorine.

7.3 Installation Considerations

- For greatest accuracy and repeatability, locate the gauge in a stable, room-temperature environment. Ambient temperature should never exceed 40 °C (104 °F) operating, non-condensing, or 85 °C (185 °F) non-operating. Bakeout temperature for the Convectron gauge is 150 °C (302 °F).
- Keep the tube clean. Do not remove the mounting port cover until you are ready to install the tube.
- Do not install the gauge where high vibration is present. Excessive vibration will cause forced convection at high pressure and provide erroneous readings.
- Locate the gauge away from internal and external heat sources and in an area where ambient temperature remains reasonably constant.
- Do not locate the gauge near the pump, where gauge pressure might be lower than normal vacuum chamber pressure.
- Do not locate the gauge near a gas inlet or other source of contamination, where inflow of gas or particulates causes atmospheric pressure to be higher than system atmosphere.
- Do not locate the gauge where it will be exposed to corrosive gases such as mercury vapor or fluorine.

7.4 Orientation

For readings below 1 Torr (1333 mbar, 133 kPa), the gauge can be installed in any orientation.

Although the Convectron gauge will read correctly below 1 Torr (1333 mbar, 133 kPa) when mounted in any position, erroneous readings will occur at pressures above 1 Torr if the gauge tube is not horizontal.

For readings above 1 Torr (1333 mbar, 133 kPa), the gauge must be installed in a horizontal position. See Figure 7-3.

Install the gauge with the gauge port oriented downward to ensure that no system condensates or other liquids collect in the gauge tube.

Figure 7-3 Convectron Gauge Mounting

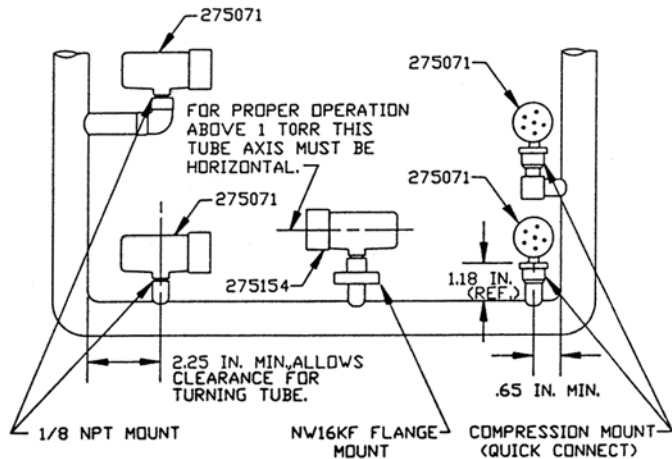

7.5 Mounting

Before you install the gauge, install appropriate pressure relief devices in the vacuum system.

Granville-Phillips does not supply pressure relief valves or rupture disks. Suppliers of pressure relief valves and rupture disks are listed in the *Thomas Register* under "Valves, Relief" and "Discs, Rupture."



CAUTION

Operating the gauge above 1000 Torr (1333 mbar, 133 kPa) true pressure could cause vacuum system rupture or product failure.

To avoid vacuum system rupture or product failure due to overpressurization, install pressure relief valves or rupture disks in the system if pressure exceeds 1000 Torr (1333 mbar, 133 kPa).

Do not use a compression mount (quick disconnect) for attaching the gauge to the system in applications resulting in positive pressures in the gauge tube. Positive pressures might blow the tube out of a compression fitting and may injure personnel or damage equipment. Pipe thread or flange mounting systems should be used for positive pressure applications.

The absolute pressure in the gauge tube should not exceed 1000 Torr (1333 mbar, 133 kPa).

Compression Mount

The gauge fits a standard 1/2 inch compression (quick-disconnect) mount.

**WARNING**

Using a compression fitting may cause ejection of the gauge tube from the fitting, resulting in property damage or personal injury.

To avoid property damage or personal injury resulting from ejection of the gauge tube, do not install a compression fitting if positive pressures occur in the vacuum system.

1. Remove the plug from the Convectron gauge tube port.
2. Insert the gauge tube port into the compression fitting and tighten the press ring by hand. If a seal is not achieved, apply a light coating of vacuum grease to the press ring.
3. Rotate the vacuum gauge in any direction for optimum routing of the cables.
4. Tighten the press ring hand tight.

1/8 NPT Mount

The gauge fits a standard 1/8 NPT female fitting.

1. Remove the plug from the Convectron gauge tube port.
2. Apply Teflon tape to the gauge tube threads.

**CAUTION**

Using a wrench to tighten the fitting to the vacuum chamber can damage the gauge's internal connections.

Do not use a wrench to tighten the fitting.

3. Insert the gauge tube port threads into the system and rotate the Convectron gauge by hand to achieve a seal.

NW Flange

The NW mounting system requires O-rings and centering rings between mating flanges.

Tighten the clamp to compress the mating flanges together and seal the O-ring.

7.6 Reading Pressure

The Convectron gauge measures the heat loss from a heated, gold-plated tungsten sensing wire that is maintained at a constant temperature.

 **WARNING**

Failure to use accurate pressure conversion data for N₂ or air to other gases can cause an explosion due to overpressurization.

If the module will measure any gas other than N₂ or air, before putting the module into operation, adjust setpoint relays for the process gas that will be used.

The vacuum pressure indicated by the gauge depends on the gas type, gas density (pressure), and the gauge orientation. The gauge is factory calibrated for N₂. (Air has approximately the same calibration.) For gases other than N₂ or air, heat loss varies at any given pressure, and you *must* apply an appropriate correction factor.

Operation Below 10⁻³ Torr

During a fast pumpdown from atmospheric pressure, thermal effects temporarily prevent the gauge from measuring pressure accurately below 10⁻³ Torr. After approximately 15 minutes, pressure indications the 10⁻⁴ Torr range will be accurate and response will be rapid.

When pressure indication in the 10⁻⁴ Torr range has stabilized, a Convectron gauge calibration at vacuum pressure may be performed. The calibration may be performed at a higher pressure if readings in the 10⁻⁴ Torr range are not required. In the 10⁻⁴ Torr range, resolution is ±0.1 millitorr, if the Convectron gauge has been properly calibrated at vacuum pressure. If the gauge frequently operates in the 10⁻⁴ Torr range, Convectron gauge calibration at vacuum pressure should be performed frequently.

Use with Gases Other Than N₂ or Air

Make sure the gain adjustment is correctly set for measuring air.

The indicated pressure depends upon the following parameters:

- Type of gas in the tube
- Tube axis orientation
- Gas pressure within the tube

Convectron gauges are calibrated for N₂ within the accuracy of the instrument. By observing certain safety precautions, the gauge tube may be used to measure the pressure of other gases.

Convectron gauge tubes are thermal conductivity gauges. These gauges transduce gas pressure by measuring the heat loss from a heated sensor wire maintained at a constant temperature. For gases other than N₂ and air, the heat loss is different at any given true pressure and the indicated pressure will be different.

Indicated Versus True Pressure

The graphs in Figure 7-4, Figure 7-5, and Figure 7-6 show the true pressure versus indicated pressure for 11 commonly used gases. See Table 7-1 to locate the proper graph for a specific application.

Table 7-1 Indicated Versus True Pressure

Range and Units	Gases	Reference Figure
1 to 100 mTorr 1.33 x 10 ⁻³ to 1.33 x 10 ⁻¹ mbar 1.33 x 10 ⁻¹ to 13.3 pascal	All	Figure 7-4, page 83
0.1 to 1000 Torr 0.133 to 1333 mbar 13.3 to 1.33 x 10 ⁵ pascal	Ar, CO ₂ , CH ₄ , Freon 12, He	Figure 7-5, page 84
0.1 to 1000 Torr 0.133 to 1333 mbar 13.3 to 1.33 x 10 ⁵ pascal	D ₂ , Freon 22, Kr, Ne, O ₂	Figure 7-6, page 85

A useful interpretation of these curves is, for example, that at a true pressure of 2 x 10⁻² Torr of CH₄ the heat loss from the sensor is the same as at a true pressure of 3 x 10⁻² of N₂ as shown in Figure 7-4. The curves at higher pressure vary widely from gas to gas because the thermal losses at higher pressures are greatly different for different gases. If you must measure the pressure of gases other than N₂ or air, use Figure 7-5 or Figure 7-6 to determine the maximum safe indicated pressure for the other gas as explained below.

Example 1 – Maximum Safe Indicated Pressure

Assume a certain system will withstand an internal pressure of 1000 Torr or 19.3 psia. For safety, limit the maximum internal pressure to 760 Torr during backfilling. Assume you want to measure the pressure of argon (Ar).

On Figure 7-5, locate 760 Torr on the left hand scale, travel to the right to the intersection with the argon curve, and then down to an indicated pressure of 24 Torr (N₂ equivalent). Thus, in this hypothetical situation, the maximum safe indicated pressure for argon is 24 Torr.

For the sake of safety, place a warning label on the instrument face which under the assumed conditions would read “DO NOT EXCEED 24 TORR FOR ARGON.”

Example 2 – Indicated To True Pressure Conversion

Assume you want to determine the true pressure of argon in a system when the gauge indicates 10 Torr. On Figure 7-5, read up from 10 Torr (N₂ equivalent) indicated pressure to the argon curve and then horizontally to the left to a true pressure of 250 Torr. Thus 250 Torr argon pressure produces an indication of 10 Torr (N₂ equivalent).

Example 3 – True To Indicated Pressure Conversion

Assume you want to set a process control trip point at a true pressure of 20 Torr of CO₂. On Figure 7-5, locate 20 Torr on the true pressure scale, travel horizontally to the right to the CO₂ curve and then down to an indicated pressure of 6 Torr (N₂ equivalent). Thus the correct process control setting for 20 Torr of CO₂ is 6 Torr (N₂ equivalent).

Example 4 – True To Indicated Pressure Conversion

Assume you want to obtain a helium (He) pressure of 100 Torr in the system. On Figure 7-5, locate 100 Torr on the left hand scale, travel horizontally to the right to attempt to intersect the helium curve. Because the intersection is off scale, this true pressure measurement requirement for helium exceeds the capability of the instrument.

For gases other than those listed, the user must provide accurate conversion data for safe operation. The Convectron gauge is not intended for use above 1000 Torr true pressure.

Figure 7-4 Gas Pressures, 1×10^{-4} to 1 Torr

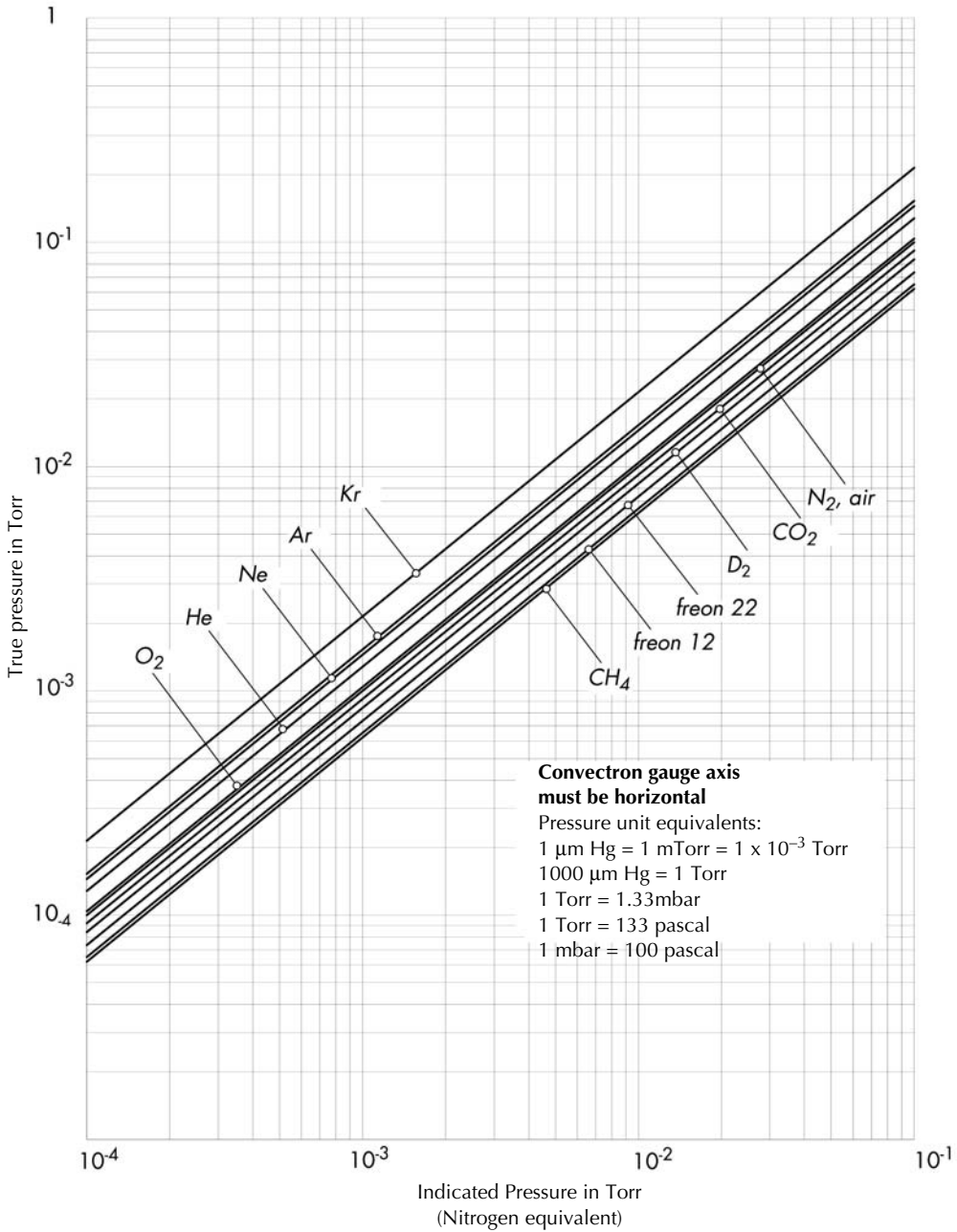

Figure 7-5 Gas Pressures, 1×10^{-2} to 1000 Torr

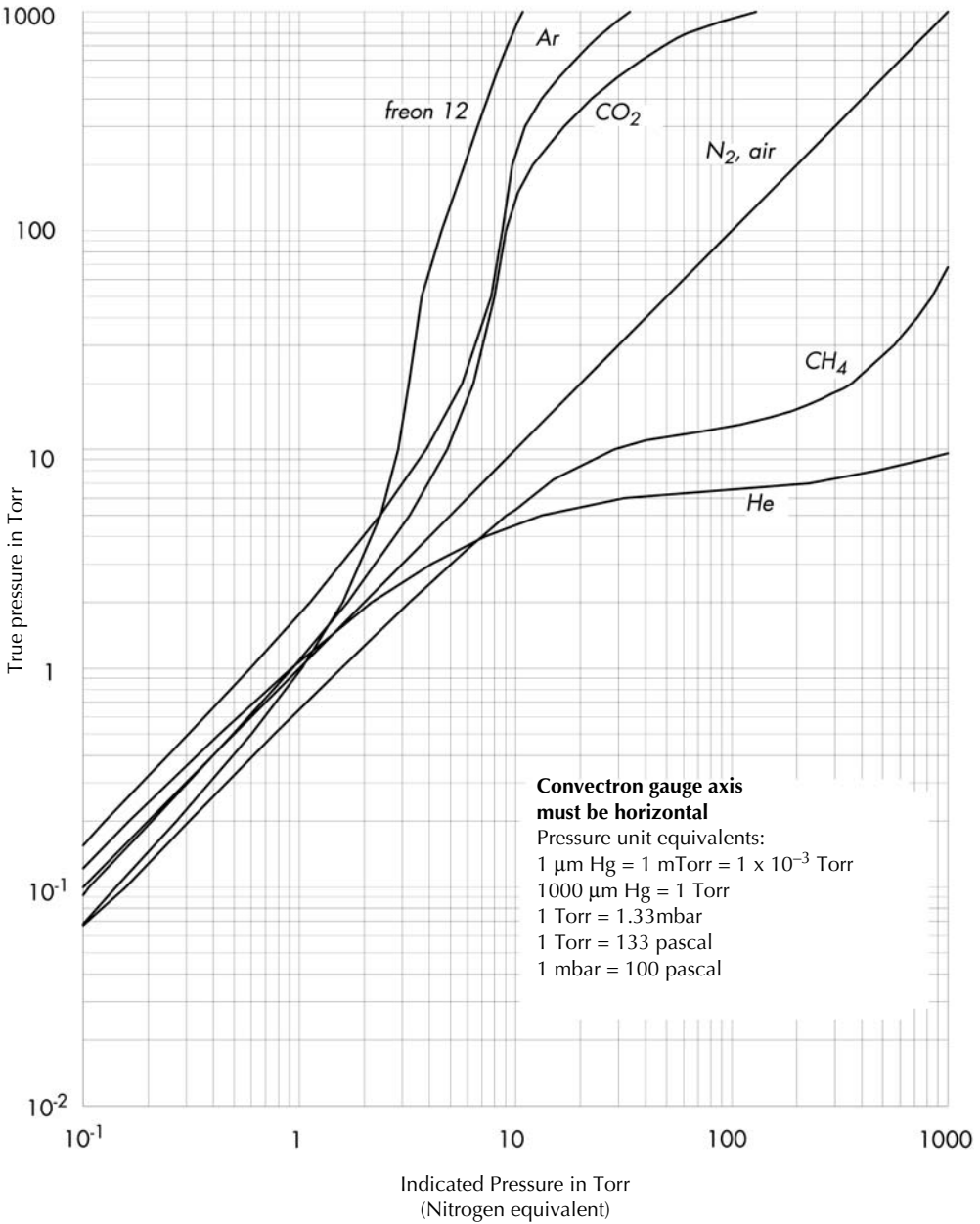
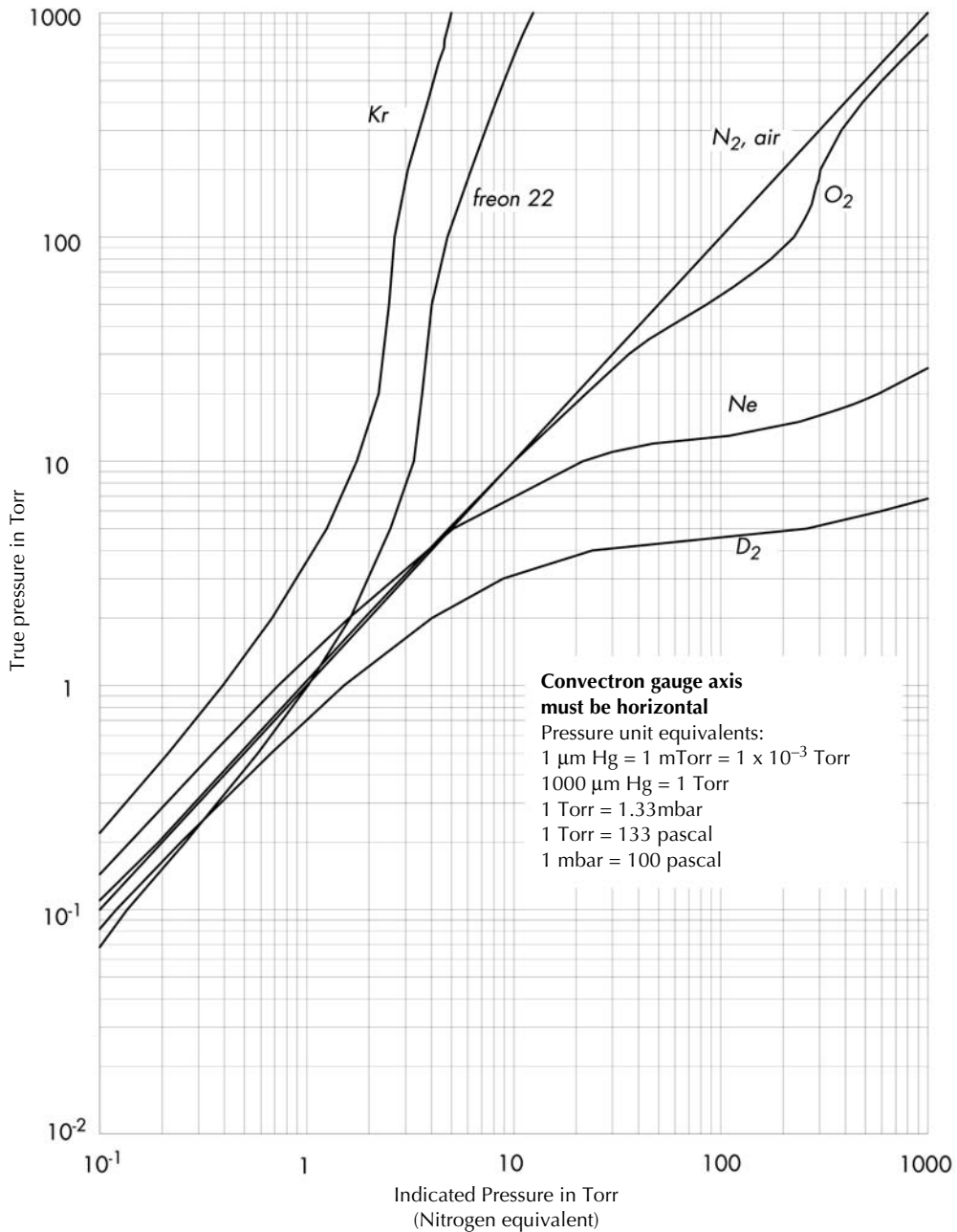

Figure 7-6 Gas Pressures, 1×10^{-2} to 1000 Torr

7.7 Unit of Measure [16 and 17]

The gauge is preset at the factory to display the pressure unit (Torr, mbar, or pascal) that you requested. To change the pressure unit, follow these steps:

1. Shut off power to the control unit.
2. Remove the top cover and locate the Convectron module.
3. Locate the mbar [16] and pascal [17] units switches.
 - Leave both switches open for Torr.
 - Close the appropriate switch for mbar or pascal.
4. Modify the pressure unit for the electrometer module to make the unit consistent with the Convectron gauge (see page 33).
5. Slip the label card out of the top of the front panel and apply the appropriate pressure unit label.

Figure 7-7 Convectron Module Top View

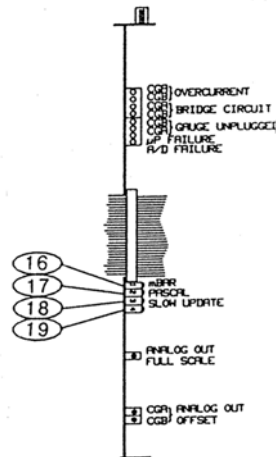
**7.8 Display Update Rate Switch [18]**

When the display update rate switch [18] is ON, the display update rate switch enables pressure averaging. The display will update approximately every three seconds. When the switch is OFF, the display will update approximately every 0.5 sec.

7.9 Analog Output [20 and 21]

Analog outputs [20 and 21] are located on the rear panel. The outputs accommodate standard 1/8-inch miniature phone jacks.

The analog outputs produce DC voltages proportional to the logarithm of pressure, scaled to 1 V per decade:

$$-7 \text{ Volts} = 1 \times 10^{-3} \text{ Torr or mbar}$$

$$-6 \text{ Volts} = 1 \times 10^{-3} \text{ Torr or mbar}$$

Internal offset adjustments allow a shift in the analog output at 10^{-4} away from 0 V to any value within the range of +7 to -1 Vdc. This adjustment does not affect the slope of the analog output versus pressure curve.

Figure 7-8 Convectron Module Rear Panel

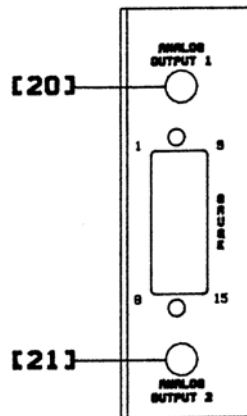
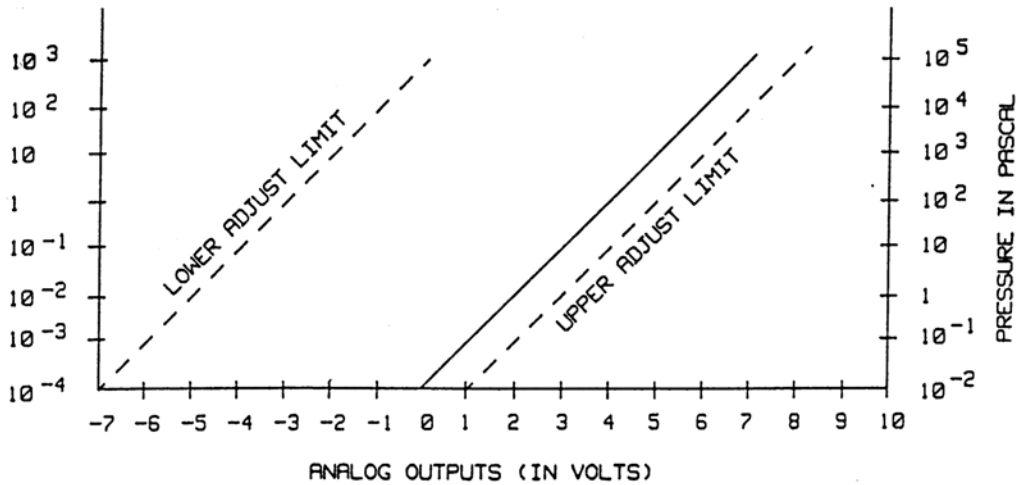

Figure 7-9 Convectron Gauge Pressure Analog Output



7.10 Calibration

Each Convectron gauge is individually calibrated for N₂ (air) and temperature compensated prior to leaving the factory. Each controller is individually calibrated to provide accurate readout of N₂ or air pressure, therefore, initial calibration should not be necessary.

Calibration should be performed if accurate pressure readings in the range of 10⁻⁴ Torr (10⁻⁴ mbar, 10⁻² pascal) are desired, if the tube becomes contaminated or does not read correctly, or for use with longer cables, you can calibrate the Convectron gauge.

Analog Output Full Scale Adjustment [27]

You may adjust the full-scale analog output to calibrate the span to the factory setting of 1 V per decade. The adjustment is common to both analog outputs.

7.11 Analog Output Offset for Gauges A and B [28 and 29]

Use the analog output offset potentiometers to adjust offset voltages for each analog output. You may set the analog output to represent 1×10^{-4} Torr (1.33×10^{-4} mbar, 1.33×10^{-2} pascal) at any voltage from -7 to $+1$ Vdc.

To establish the factory calibration, adjust [28] and [29] to yield a -7 V outputs when both gauges are at less than 1×10^{-4} Torr (1.33×10^{-4} mbar, 1.33×10^{-2} pascal), then adjusting [27] to increase 1 V per decade of pressure increase.

Figure 7-10 Convectron Module Top View

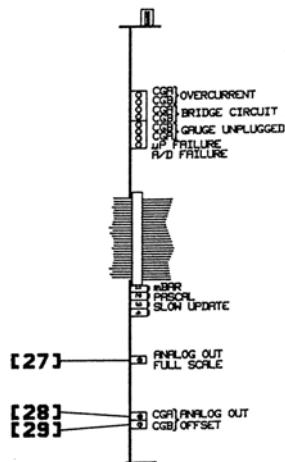

Zero Adjustment [23 and 26]

1. Evacuate the chamber to a pressure that is less than 1×10^{-4} Torr (1.33×10^{-4} mbar, 1.33×10^{-2} pascal).
2. With the gauge operating, adjust the VAC potentiometer until a single "0" appears in the display. If the adjustment is turned too far past zero, a minus sign (-) appears in the display. The calibration is correct only when the single "0" appears in the display.

Figure 7-11 Convectron Module Front Panel

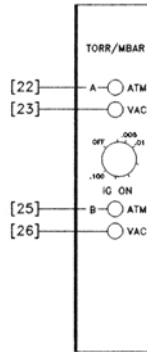

Atmosphere Adjustment [22 and 25]

1. Allow system pressure to increase to the atmospheric pressure of N_2 or air.
 2. Adjust the ATM potentiometer until the displayed pressure is the same as atmospheric pressure indicated by an accurate barometer. Use absolute pressure, not corrected to sea level.
- 1 atmosphere normal at sea level= 7.6×10^2 Torr
 1.0×10^{-3} mbar
 1.0×10^{-5} pascal

A

Available Options 13

B

Baud Rate Switch Settings 47

Before You Begin 9

C

Caution and warning statements 9

Character Framing Switch Settings 47

Control Unit Front Panel 26

Control Unit Rear Panel 26

Controller Specifications 30

Convectron® Gauge Module 73

E

Electrometer Calibration 39

Electrometer Calibration 39

Electrometer Module 34

Electrometer Module 33

Explosive Gases 11

G

General Description 13

I

Implosion / Explosion 11

Installation 14

Ion Gauge Electrometer Module 38

Ionization Gauge Theory of Operation 28

Ionization Gauge Types and Installation 19

L

LETHAL VOLTAGES 10

Line Voltage Selector Card 14

Line Voltage Selector Settings 14

M

Mounting Options 14

N

Nude Gauge Base Configuration 20

P

Process Control Module 41

Process Control Operation 44

Process Control Specifications 45

Process Control System Connections 41

Process Control Theory of Operation 45

Process control, RS-232, and RS-485 interface
connectors 59

Process control, RS-232, and RS-485 module 56

Process Control Module 43

R

Read and follow these instructions 10

Remote Input/Output Pin Functions 28

Returning a product for service 12

RS-232 Interface 47

RS-232 Module 47

RS-232 Specifications 53

RS-232 Theory of Operation 51

RS-232/RS-485 specifications 72

S

System Ground Test Procedure 24

System Grounding 10

U

Units of Measure 33

Z

Line Voltage Selection 14

Series 350

Granville-Phillips® Series 350 UHV Gauge Controller



6450 Dry Creek Parkway

Longmont, CO 80503 USA
Phone: 1-303-652-4400

15 Elizabeth Drive

Chelmsford, MA 01824 USA
Phone: 1-978-262-2400

Worldwide Customer Service/Support - 24/7
Phone: 1-800-367-4887

To obtain a copy of this instruction manual online,
visit our website at www.brooks.com

(Adobe® Reader® version 5.0 or higher required)

© 2006-2009 Brooks Automation, Inc.

Instruction Manual

Instruction manual part number 350010

Revision 05 - February 2009